

Normanby Park Sport & Activity Club

Installation :

Project number : P14157R1
Customer : Paul Cowling.
Processed by : Hammy
Date : 30.06.2009

Project description:
Reschemed car park using 150W SON Toledo fittings.

The following values are based on exact calculations on calibrated lamps, luminaires and their arrangement. In practice, gradual divergences can occur.

Guarantee claims for luminaire data are excluded.

Relux and the luminaire manufacturers accept no liability for consequential damage and damage which is occasioned to the user or to third parties.

Object : Cricket/Tennis Club, Scunthorpe.
Installation :
Project number : P14157R1
Date : 30.06.2009



Table of contents

First Page	1
Table of contents	2
1 Luminaire data	
1.1 2kW Flood (16m Column)	
1.1.1 Data sheet	3
1.2 150W SON TOLEDO (8M COLUMN)	
1.2.1 Data sheet	5
2 Sports Pitch	
2.1 Description, Sports Pitch	
2.1.1 Luminaire data/Room elements	7
2.1.2 Floor plan	9
2.2 Summary, Sports Pitch	
2.2.1 Result overview, Reference plane 1	10
2.3 Calculation results, Sports Pitch	
2.3.1 Table, Reference plane 1 (E)	11
2.3.2 Pseudo colours, Reference plane 1 (E)	13
2.3.3 3D luminance, View 1	14
3 Car Park	
3.1 Description, Car Park	
3.1.1 Luminaire data/Room elements	15
3.1.2 Floor plan	16
3.2 Summary, Car Park	
3.2.1 Result overview, Reference plane 1	17
3.3 Calculation results, Car Park	
3.3.1 Table, Reference plane 1 (E)	18
3.3.2 Pseudo colours, Reference plane 1 (E)	20

Object : Cricket/Tennis Club, Scunthorpe.
Installation :
Project number : P14157R1
Date : 30.06.2009



1 Luminaire data

1.1 2kW Flood (16m Column)

1.1.1 Data sheet

16m Column 2kW Flood

Luminaire arrangement for:

	Position			Rotation		
	x[m]	y[m]	z[m]	Z[°]	C0[°]	C90[°]
!AFG-LPH2KTC-NONE 1x2000W	0.000	0.300	16.000	0	0	0

Position is the LDC position of the luminaire.

!AFG-LPH2KTC-NONE Area Floods GRANDE 2kW HQI

GRANDE (2 kWatt)-IP65 rated with dry powder coated aluminium body and toughened glass cover. E40 lampholder.

Metal Halide-T-2KW, Clear GES (E40) Universal burn

Temperature 4000 K-Rendering Group 60 (Osram, Flux in Lumens :240000)

No optically distorting accessory fitted

Luminaire data

Luminaires efficiency : 80.29% (A60)
 ↓ 99.4% ↑ 0.6%

Control gear : conventional ballast, comp., with ignition device

System power : 2180 W

Length : 500 mm

Width : 595 mm

Height : 295 mm

Equipped with

Number of : 1

Designation :

Power : 2000 W

Colour : 4000K

Luminous flux : 180000 lm

Object : Cricket/Tennis Club, Scunthorpe.
Installation :
Project number : P14157R1
Date : 30.06.2009



1 Luminaire data

1.1 2kW Flood (16m Column)

1.1.1 Data sheet

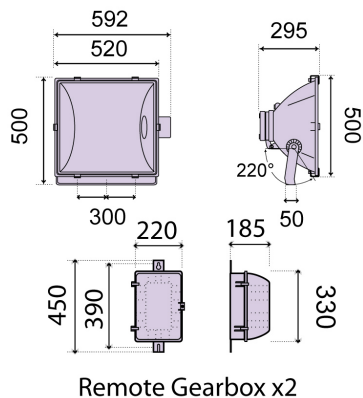
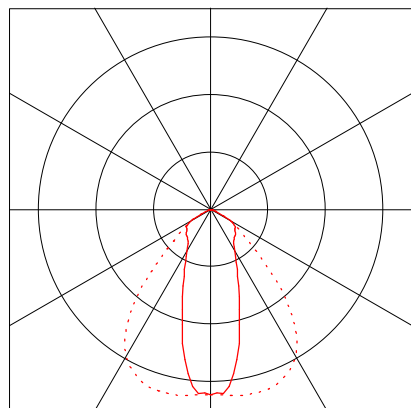

Object : Cricket/Tennis Club, Scunthorpe.
 Installation :
 Project number : P14157R1
 Date : 30.06.2009



1 Luminaire data

1.2 150W SON TOLEDO (8M COLUMN)

1.2.1 Data sheet

8M COLUMN 150W SON TOLEDO

Luminaire arrangement for:

8M COLUMN	Position			Rotation		
	x[m]	y[m]	z[m]	Z[°]	C0[°]	C90[°]
RLT-LPS150PT-NONE 1x150W :	0.000	0.500	8.000	0	15	0

Position is the LDC position of the luminaire.

RLT-LPS150PT-NONE Road Lights TOLEDO

TOLEDO Road Light-Die-cast aluminium luminaire with toughened glass diffuser, finished with a light grey polyester coating. Optical unit IP65, with IP43 gear housing.

High Pressure Sodium SON-T-150W-PLUS (Super), GES E40, without internal ignitor. (Universal)

Temperature 2000 K-Rendering Group 25 (G.E., Flux in Lumens :17500)

No optically distorting accessory fitted

Luminaire data

Luminaires efficiency : 93.68% (A40)
 ↓ 100.0% ↑ 0.0%

Control gear : conventional ballast, comp., with ignition device

System power : 173 W

Length : 650 mm

Width : 300 mm

Height : 290 mm

Equipped with

Number of : 1

Designation :

Power : 150 W

Colour : 2000K

Luminous flux : 17500 lm

Object : Cricket/Tennis Club, Scunthorpe.
Installation :
Project number : P14157R1
Date : 30.06.2009



1 Luminaire data

1.2 150W SON TOLEDO (8M COLUMN)

1.2.1 Data sheet

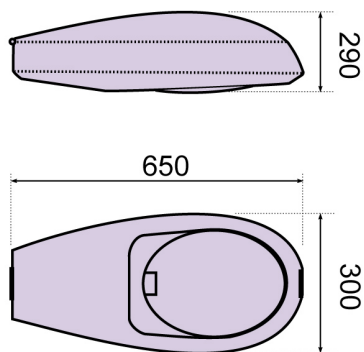
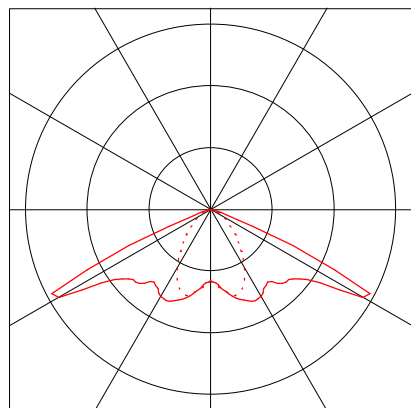

Object : Cricket/Tennis Club, Scunthorpe.
 Installation :
 Project number : P14157R1
 Date : 30.06.2009



2 Sports Pitch

2.1 Description, Sports Pitch

2.1.1 Luminaire data/Room elements

Luminaire data:

Type No.\Make

2 10 Order No. : 16m Column
 Luminaire name : 2kW Flood
 with : 1 x !AFG-LPH2KTC-NONE
 Equipment : 1 x MH-T_E40_Clear_U 2000 W / 180000 lm

	Position			za	Rotation	
	x[m]	y[m]	z[m]		xa	ya
2kW Flood/16m Column						
15	10.30	0.00	0.00	0.0°	0.0°	0.0°
Orientation	Target coordinates				Rotation	
1 !AFG-LPH2KTC-NONE	10.30	19.54	0.00	90.0°	0.0°	-50.0°
19	92.70	0.00	0.00	0.0°	0.0°	0.0°
Orientation	Target coordinates				Rotation	
1 !AFG-LPH2KTC-NONE	92.70	19.54	0.00	90.0°	0.0°	-50.0°
20	30.90	56.50	0.00	180.0°	0.0°	0.0°
Orientation	Target coordinates				Rotation	
1 !AFG-LPH2KTC-NONE	30.90	36.96	0.00	270.0°	0.0°	-50.0°
21	72.10	0.00	0.00	0.0°	0.0°	0.0°
Orientation	Target coordinates				Rotation	
1 !AFG-LPH2KTC-NONE	72.10	19.54	0.00	90.0°	0.0°	-50.0°
22	92.62	56.50	0.00	180.0°	0.0°	0.0°
Orientation	Target coordinates				Rotation	
1 !AFG-LPH2KTC-NONE	92.62	36.96	0.00	270.0°	0.0°	-50.0°
23	51.50	0.00	0.00	0.0°	0.0°	0.0°
Orientation	Target coordinates				Rotation	
1 !AFG-LPH2KTC-NONE	51.50	19.54	0.00	90.0°	0.0°	-50.0°
24	72.10	56.50	0.00	180.0°	0.0°	0.0°
Orientation	Target coordinates				Rotation	
1 !AFG-LPH2KTC-NONE	72.10	36.96	0.00	270.0°	0.0°	-50.0°
25	30.90	0.00	0.00	0.0°	0.0°	0.0°
Orientation	Target coordinates				Rotation	
1 !AFG-LPH2KTC-NONE	30.90	19.54	0.00	90.0°	0.0°	-50.0°
26	51.42	56.50	0.00	180.0°	0.0°	0.0°
Orientation	Target coordinates				Rotation	
1 !AFG-LPH2KTC-NONE	51.42	36.96	0.00	270.0°	0.0°	-50.0°
27	10.30	56.50	0.00	180.0°	0.0°	0.0°
Orientation	Target coordinates				Rotation	
1 !AFG-LPH2KTC-NONE	10.30	36.96	0.00	270.0°	0.0°	-50.0°

Object : Cricket/Tennis Club, Scunthorpe.
Installation :
Project number : P14157R1
Date : 30.06.2009



2 Sports Pitch

2.1 Description, Sports Pitch

2.1.1 Luminaire data/Room elements

Structural elements

Virtual measuring surface

No.	xm[m]	ym[m]	zm[m]	Length	Width	z axis	Rotation angle	
							L axis	Q axis
Ref. plane 1	51.50	28.25	0.00	123.00	76.50	0.00	0.00	0.00

Object : Cricket/Tennis Club, Scunthorpe.
Installation :
Project number : P14157R1
Date : 30.06.2009



2.1 Description, Sports Pitch

2.1.2 Floor plan

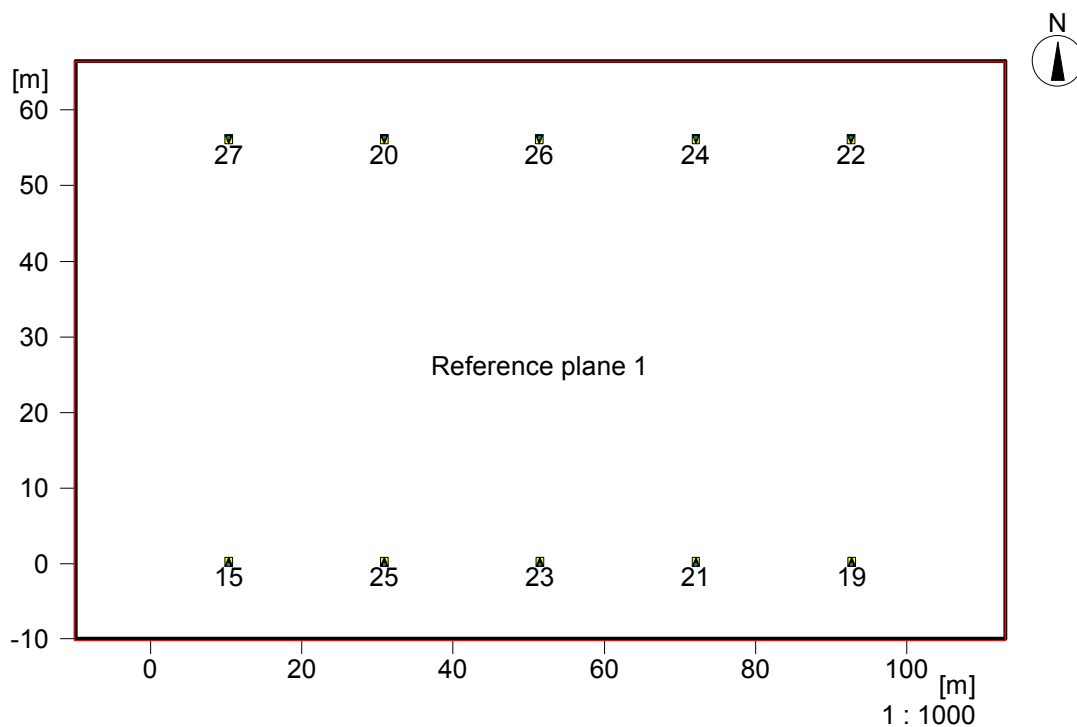

Object : Cricket/Tennis Club, Scunthorpe.
 Installation :
 Project number : P14157R1
 Date : 30.06.2009



2 Sports Pitch

2.2 Summary, Sports Pitch

2.2.1 Result overview, Reference plane 1

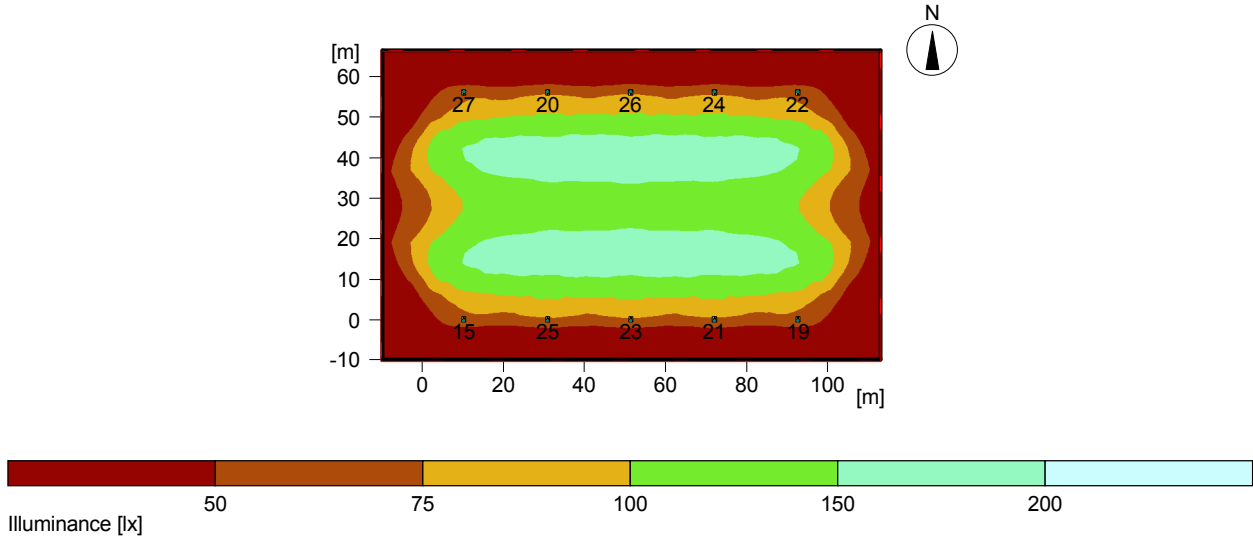

General

Calculation algorithm used	Average indirect fraction
Height of evaluation surface	0.00 m
photometric centre height. [m]:	16.05 m
Maintenance factor	0.70
Total luminous flux of all lamps	1800000 lm
Total power	21800 W
Total power per area (9409.50 m ²)	2.32 W/m ² (2.66 W/m ² /100lx)

Illuminance

Average illuminance	Eav	87 lx
Minimum illuminance	Emin	3 lx
Maximum illuminance	E _{max}	182 lx
Uniformity g1	E _{min} /E _m	1:29 (0.03)
Uniformity g2	E _{min} /E _{max}	1:60.4 (0.02)

Type No.\Make

2	10	Order No.	: 16m Column
		Luminaire name	: 2kW Flood
		with	: 1 x !AFG-LPH2KTC-NONE
		Equipment	: 1 x MH-T_E40_Clear_U 2000 W / 180000 lm

Object : Cricket/Tennis Club, Scunthorpe.
 Installation :
 Project number : P14157R1
 Date : 30.06.2009



2 Sports Pitch

2.3 Calculation results, Sports Pitch

2.3.1 Table, Reference plane 1 (E)

7	7	7	7	7	7	7	6	6	6	6	6	6	6	5	5	5	5	5	4	4	4	(3)	(3)	
9	9	9	9	9	9	9	9	9	8	8	8	8	8	8	8	7	6	6	5	5	4	4	4	
14	13	15	13	15	17	18	18	15	13	12	13	12	13	15	15	15	13	11	8	8	7	5	5	4
55	51	53	54	55	59	61	60	56	55	51	52	52	53	56	58	56	50	46	37	27	17	12	9	7
76	73	73	76	78	79	80	80	78	76	73	71	73	75	75	72	70	64	56	47	37	29	23	17	13
88	88	87	88	87	91	90	91	89	86	86	85	84	82	83	80	77	71	61	55	45	35	27	22	17
106	106	105	106	102	108	106	108	102	104	103	102	101	96	97	95	91	83	76	67	54	40	32	25	20
134	131	130	133	130	129	127	130	124	131	128	124	127	123	117	115	110	98	96	84	65	51	40	30	23
161	159	158	160	160	153	154	155	156	158	155	152	152	151	141	138	132	121	113	97	80	65	50	37	27
178	176	176	177	177	175	176	174	174	174	171	169	168	166	161	155	146	133	121	105	89	74	59	45	33
179	179	179	178	177	177	178	176	175	174	173	171	168	164	159	153	143	130	117	104	90	77	64	51	39
174	175	175	173	171	168	166	166	167	168	168	166	162	156	148	137	128	119	109	99	89	77	66	54	43
152	152	152	151	151	153	153	151	148	146	144	142	138	133	129	123	115	105	95	86	77	68	59	50	42
138	137	137	137	137	137	138	137	134	131	129	126	123	118	114	110	103	94	86	78	70	61	54	46	39
131	131	130	130	129	130	130	130	126	124	122	119	115	111	107	103	97	89	82	74	66	58	51	45	38
131	131	130	130	129	130	130	130	126	124	122	119	115	111	107	103	97	89	82	74	67	58	51	45	38
138	137	137	137	137	137	138	137	133	131	129	126	123	118	114	110	103	94	86	78	70	61	54	46	39
152	152	152	151	151	153	153	151	148	146	144	142	138	133	129	123	115	105	95	87	77	68	59	50	42
174	175	175	174	171	168	166	166	167	168	168	166	162	156	147	137	128	119	110	100	89	78	66	54	43
179	179	179	178	178	177	178	176	175	173	172	170	168	164	159	152	143	130	117	104	91	78	64	51	39
178	176	176	177	177	176	176	174	173	173	170	168	167	166	160	155	146	133	121	105	89	74	59	46	33
161	159	158	161	160	153	154	155	156	158	154	151	152	151	141	138	132	120	113	97	80	65	51	38	28
134	131	131	133	130	129	127	130	124	131	128	124	126	123	114	115	110	98	95	84	66	51	40	30	23
106	106	106	106	103	108	106	108	102	104	102	102	100	96	97	95	91	84	74	67	54	41	32	25	20
88	88	88	88	87	91	90	91	89	86	86	85	84	82	83	80	77	71	62	55	45	35	28	22	17
77	73	73	76	78	80	80	80	78	76	72	71	72	74	74	72	70	64	56	47	38	29	23	17	13
55	51	53	54	55	59	61	60	56	55	51	51	51	52	56	58	56	51	46	38	27	17	12	9	7
14	13	15	13	15	17	18	18	15	13	12	13	11	13	15	15	15	14	11	8	8	7	5	5	4
9	9	9	9	9	9	9	9	9	8	8	8	8	8	8	8	7	6	6	5	5	4	4	4	4
7	7	7	7	7	7	7	6	6	6	6	6	6	6	5	5	5	5	4	4	4	4	(3)	(3)	(3)
					80									100										120 [m]

Part2

Object : Cricket/Tennis Club, Scunthorpe.
 Installation :
 Project number : P14157R1
 Date : 30.06.2009



2.3 Calculation results, Sports Pitch

2.3.2 Pseudo colours, Reference plane 1 (E)

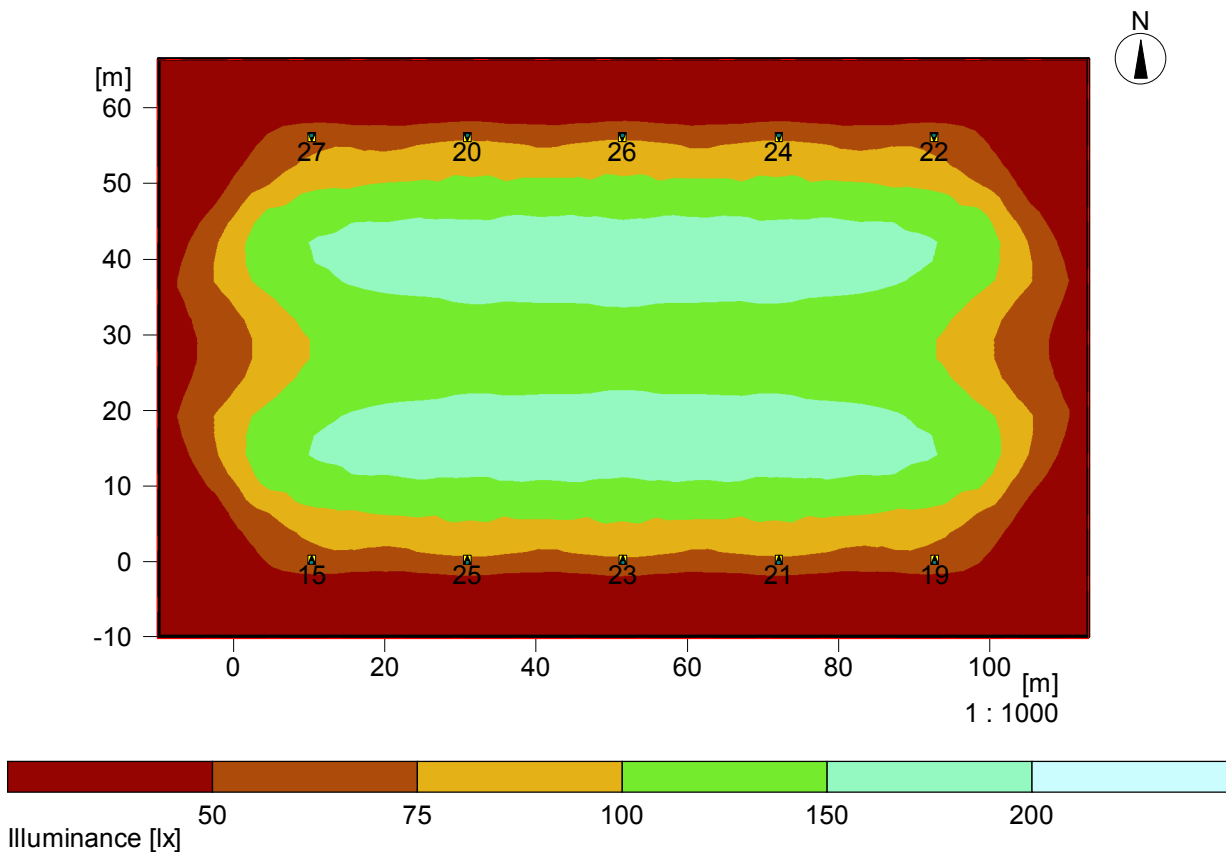

Height of the reference plane	:	0.00 m
Average illuminance	Eav	: 87 lx
Minimum illuminance	Emin	: 3 lx
Maximum illuminance	Emax	: 182 lx
Uniformity g1	Emin/Eav	: 1 : 28.99 (0.03)
Uniformity g2	Emin/Emax	: 1 : 60.43 (0.02)

Object : Cricket/Tennis Club, Scunthorpe.
Installation :
Project number : P14157R1
Date : 30.06.2009



2.3 Calculation results, Sports Pitch

2.3.3 3D luminance, View 1

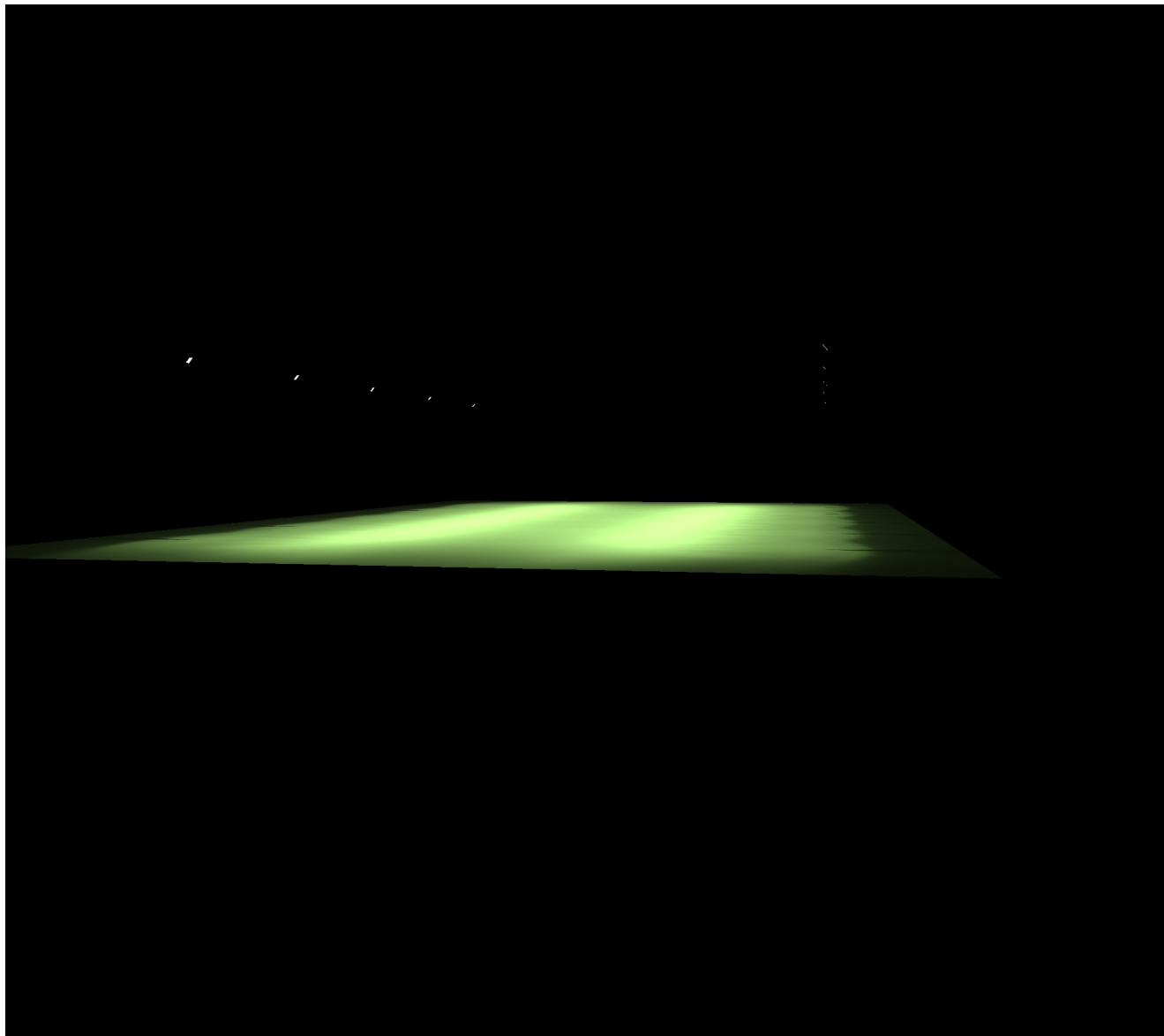

Luminance in the scene
Minimum: : 0 cd/m²
Maximum: : 97.9 cd/m²

Object : Cricket/Tennis Club, Scunthorpe.
 Installation :
 Project number : P14157R1
 Date : 30.06.2009



3 Car Park

3.1 Description, Car Park

3.1.1 Luminaire data/Room elements

Luminaire data:

Type No.\Make

6	5	Order No.	: 8M COLUMN
		Luminaire name	: 150W SON TOLEDO
		with	: 1 x RLT-LPS150PT-NONE
		Equipment	: 1 x SON-T_E40_E_U 150 W / 17500 lm

	x[m]	Position y[m]	z[m]	za	Rotation xa	ya
150W SON TOLEDO/8M COLUMN						
11	1.50	0.00	0.00	0.0°	0.0°	0.0°
12	26.50	0.00	0.00	0.0°	0.0°	0.0°
13	51.50	0.00	0.00	0.0°	0.0°	0.0°
14	76.50	0.00	0.00	0.0°	0.0°	0.0°
15	101.50	0.00	0.00	0.0°	0.0°	0.0°

Structural elements

Virtual measuring surface

No.	xm[m]	ym[m]	zm[m]	Length	Width	z axis	Rotation angle L axis	Q axis
Ref. plane 1	51.50	5.00	0.00	103.00	10.00	0.00	0.00	0.00

Object : Cricket/Tennis Club, Scunthorpe.
Installation :
Project number : P14157R1
Date : 30.06.2009



3.1 Description, Car Park

3.1.2 Floor plan

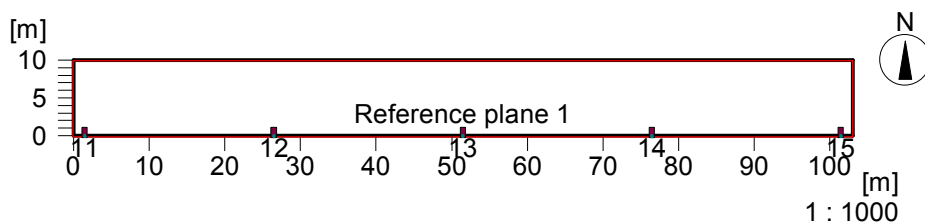

Object : Cricket/Tennis Club, Scunthorpe.
 Installation :
 Project number : P14157R1
 Date : 30.06.2009



3 Car Park

3.2 Summary, Car Park

3.2.1 Result overview, Reference plane 1

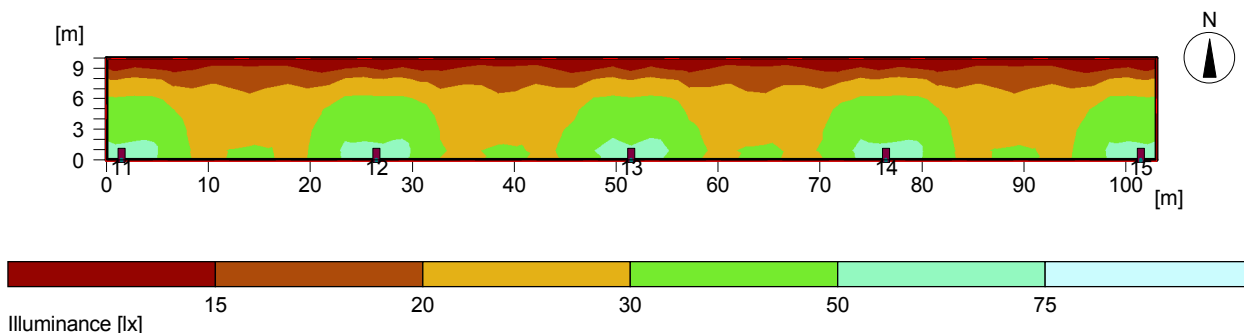

General

Calculation algorithm used	Average indirect fraction
Height of evaluation surface	0.00 m
photometric centre height. [m]:	8.00 m
Maintenance factor	0.70
Total luminous flux of all lamps	87500 lm
Total power	865 W
Total power per area (1030.00 m ²)	0.84 W/m ² (2.98 W/m ² /100lx)

Illuminance

Average illuminance	Eav	28.1 lx
Minimum illuminance	Emin	13.2 lx
Maximum illuminance	Emax	57.1 lx
Uniformity g1	Emin/Em	1:2.12 (0.47)
Uniformity g2	Emin/Emax	1:4.31 (0.23)

Type No.\Make

6	5	Order No.	: 8M COLUMN
		Luminaire name	: 150W SON TOLEDO
		with	: 1 x RLT-LPS150PT-NONE
		Equipment	: 1 x SON-T_E40_E_U 150 W / 17500 lm

Object : Cricket/Tennis Club, Scunthorpe.
 Installation :
 Project number : P14157R1
 Date : 30.06.2009



3 Car Park

3.3 Calculation results, Car Park

3.3.1 Table, Reference plane 1 (E)

[m]	(13.2)	15.3	14.5	13.4	14.4	15.6	15.7	15.4	15.8	15.6	14.4	13.5	14.7	15.5	13.9	15.4	13.8	14.1	15.1	15.9	15.4	15.6	15.9	14.7	13.5	14.2	15.6	
8	24.7	25.7	25.1	20.8	20.1	21.3	20.1	19.2	20.2	21.3	20.1	21.1	25.3	25.9	25.4	25.3	22.9	20	21	20.9	19.2	19.5	21.3	20.4	20.4	24.8	25.7	
6	37.4	38.3	38.1	30.2	24.5	25.9	23.8	22.5	23.9	25.9	24.6	30.8	38.4	38.5	37.9	38.3	33.5	25.7	25.4	25	22.8	23.3	25.7	24.8	27.5	36.9	38.6	
4	41.4	42.9	44.6	35.8	27.5	27.5	26.5	25	26.5	27.7	27.6	36.5	44.8	42.8	41.6	45.9	40	29.6	28.1	26.8	25.1	25.7	27.3	28.1	32.3	43.9	45.7	
2	53.8	56	53.8	36.9	29.4	28.4	30.4	31.4	30.5	28.5	29.5	37.6	54.4	56	54.3	55.5	42.9	30.5	29.1	29.8	32	31.1	28.8	29.9	33.5	49.7	57.1	
1																												
						10						20																50
	Illuminance [lx]																											

Part1

Height of the reference plane		: 0.00 m
Average illuminance	Eav	: 28.1 lx
Minimum illuminance	Emin	: 13.2 lx
Maximum illuminance	Emax	: 57.1 lx
Uniformity g1	Emin/Eav	: 1 : 2.12 (0.47)
Uniformity g2	Emin/Emax	: 1 : 4.31 (0.23)

Object : Cricket/Tennis Club, Scunthorpe.
 Installation :
 Project number : P14157R1
 Date : 30.06.2009



3 Car Park

3.3 Calculation results, Car Park

3.3.1 Table, Reference plane 1 (E)

13.5	15.6	14.2	13.5	14.7	15.9	15.6	15.4	15.9	15.1	14.1	13.8	15.4	13.9	15.5	14.7	13.5	14.4	15.6	15.8	15.4	15.7	15.6	14.4	13.4	14.5	15.3	(13.2)
24.5	25.7	24.8	20.4	20.4	21.3	19.5	19.2	20.9	21	20	22.9	25.3	25.4	25.9	25.3	21.1	20.1	21.3	20.2	19.2	20.1	21.3	20.1	20.8	25.1	25.7	24.7
37.5	38.6	36.9	27.5	24.8	25.7	23.3	22.8	25	25.4	25.7	33.5	38.3	37.9	38.5	38.4	30.8	24.6	25.9	23.9	22.5	23.8	25.9	24.5	30.2	38.1	38.3	37.4
40.9	45.7	43.9	32.3	28.1	27.3	25.7	25.1	26.8	28.1	29.6	40	45.9	41.6	42.8	44.8	36.5	27.6	27.7	26.5	25	26.5	27.5	27.5	35.8	44.6	42.9	41.4
53	[57.1]	49.7	33.5	29.9	28.8	31.1	32	29.8	29.1	30.5	42.9	55.5	54.3	56	54.4	37.6	29.5	28.5	30.5	31.4	30.4	28.4	29.4	36.9	53.8	56	53.8
				60						70					80						90						100 [m]

Part2

Object : Cricket/Tennis Club, Scunthorpe.
Installation :
Project number : P14157R1
Date : 30.06.2009



3.3 Calculation results, Car Park

3.3.2 Pseudo colours, Reference plane 1 (E)

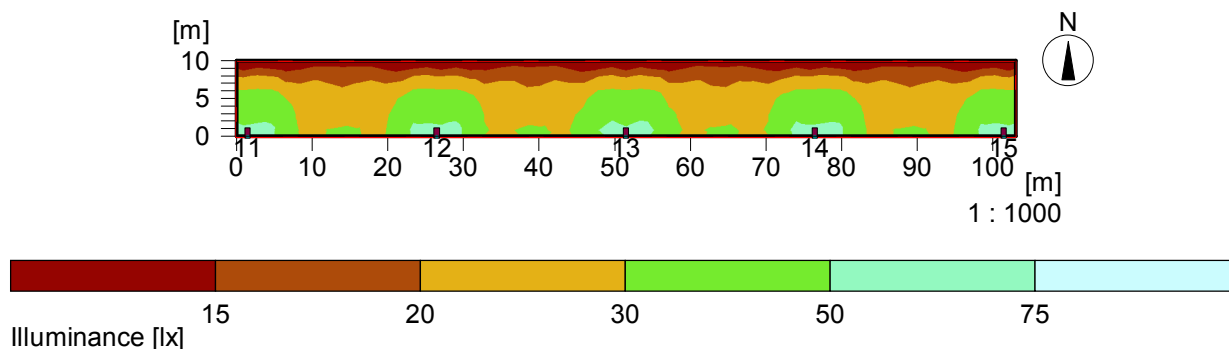

Height of the reference plane : 0.00 m
Average illuminance Eav : 28.1 lx
Minimum illuminance Emin : 13.2 lx
Maximum illuminance Emax : 57.1 lx
Uniformity g1 Emin/Eav : 1 : 2.12 (0.47)
Uniformity g2 Emin/Emax : 1 : 4.31 (0.23)