

All dimensions and levels to be verified on site. Only figured dimensions to be used. Do not scale this drawing. Any discrepancies to be notified to the originator of the drawing immediately. If in doubt ask. Copyright reserved, the drawing is issued on the condition that it is not copied, reproduced, retained or disclosed to any unauthorized person either wholly or in part without consent.

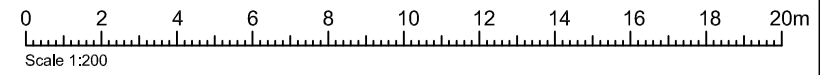

Home Improvement Team
Neighbourhood and Environmental Services
PO Box 42, Church Square House
Scunthorpe, North Lincolnshire
DN15 6XQ

PRELIMINARY

Notes:

Rev	Date	Comment
Rev A	11/10	Consultation issue
Rev B	05/11	Site plan

Disabled Adaptations for:
Miss Mumby
49 Townhill
Broughton
DN20 0HD

Drawing Title:
Site Plan

Scale:
1:200 @ A3

Drawn By:
A Tutty

Drawing No:
01

Date:
November 2010

Revision: B	Checked:
----------------	----------

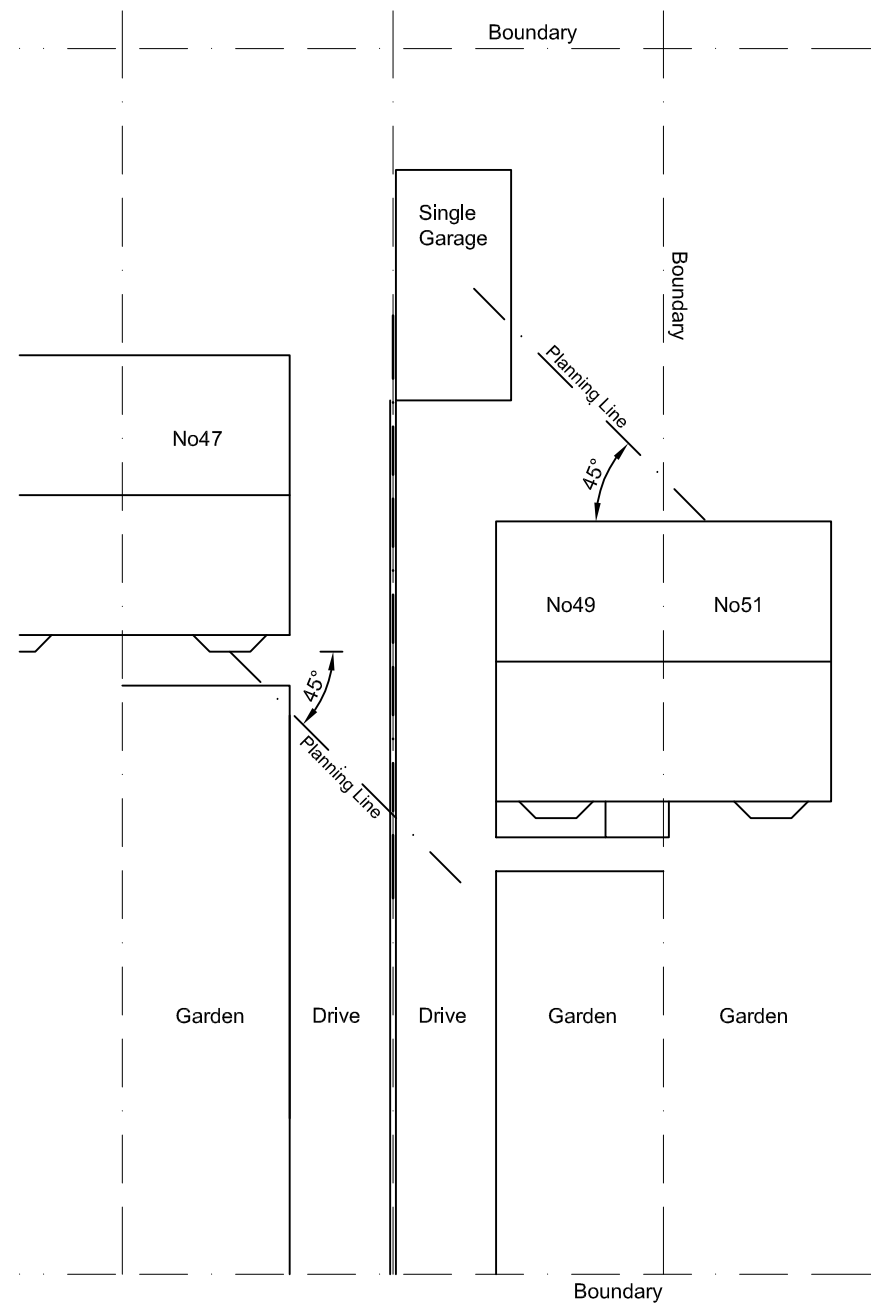

EXISTING PLAN

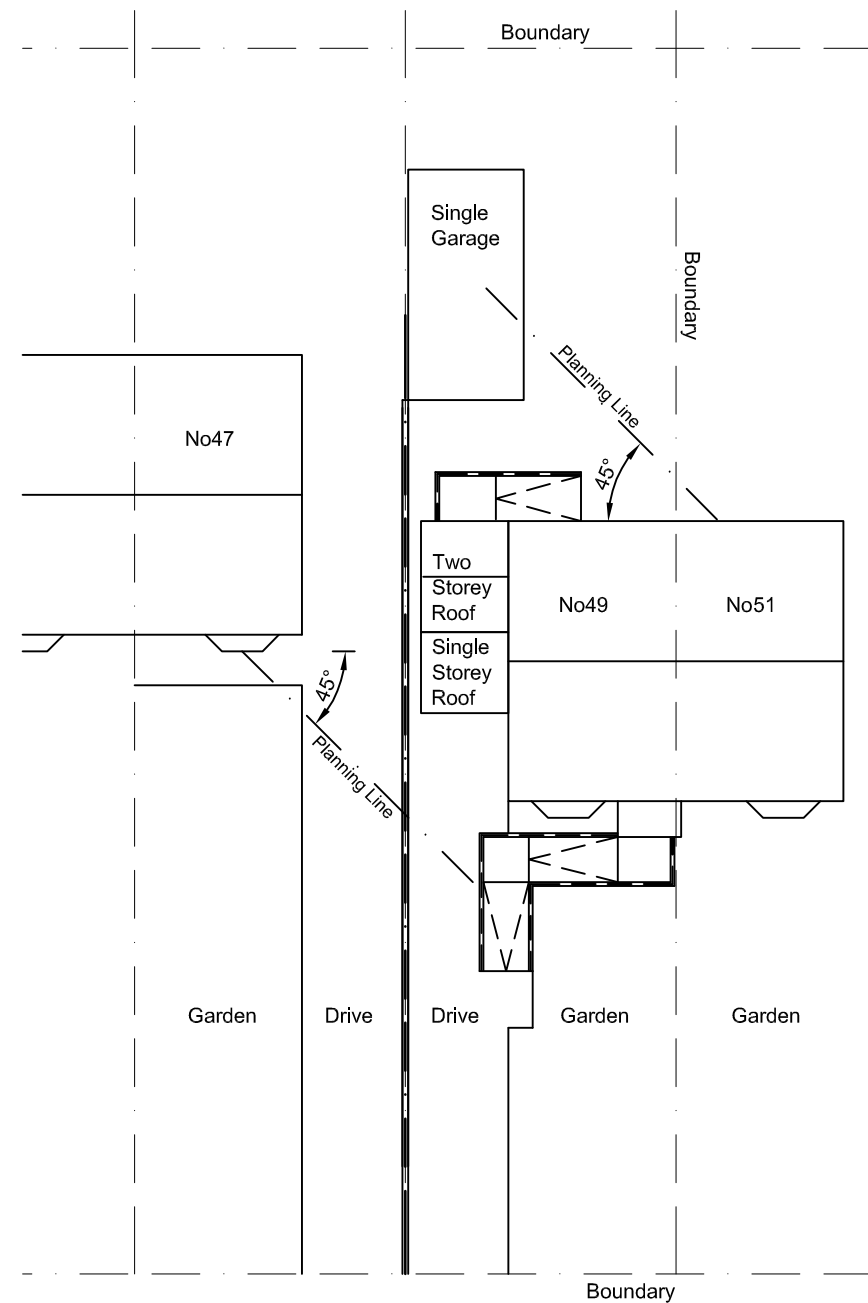

PROPOSED PLAN

All dimensions and levels to be verified on site. Only figured dimensions to be used. Do not scale this drawing. Any discrepancies to be notified to the originator of the drawing immediately. If in doubt ask. Copyright reserved, the drawing is issued on the condition that it is not copied, reproduced, retained or disclosed to any unauthorised person either wholly or in part without consent.

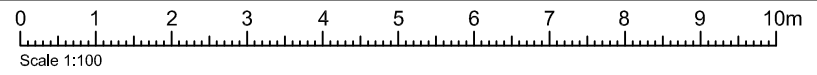

Home Improvement Team
Neighbourhood and Environmental
Services
PO Box 42, Church Square House
Scunthorpe, North Lincolnshire
DN15 6XQ

PRELIMINARY

Rev	Date	Comment
Rev A	11/10	Consultation issue

Disabled Adaptations for:
Miss Mumby
49 Townhill
Broughton
DN20 0HD

Drawing Title:
Elevations - Existing

Scale:
1:100 @ A3

Drawn By:
A Tutty

Drawing No:
02

Date:
November 2010

Revision: A	Checked:
----------------	----------

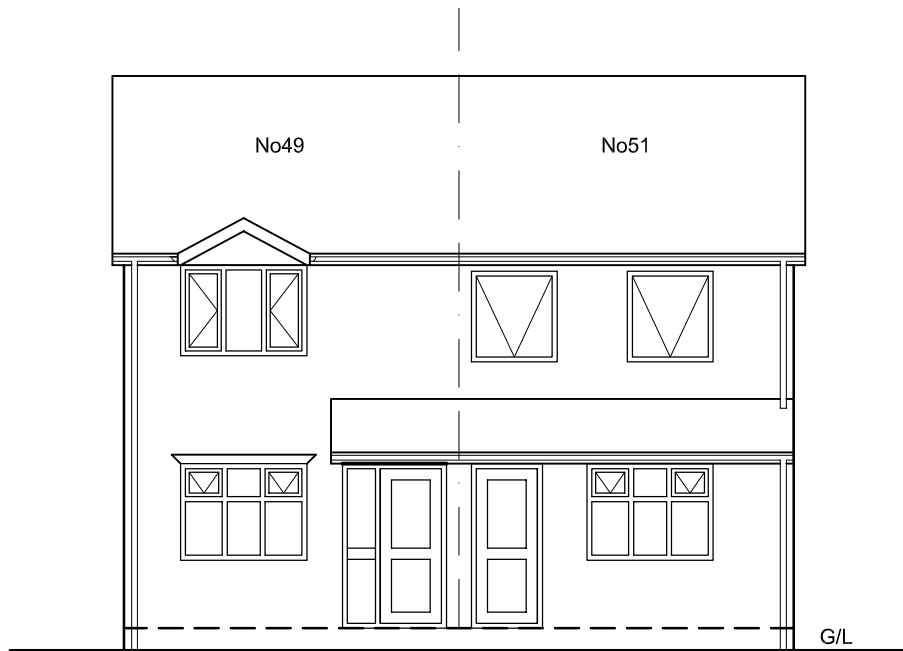

NORTH ELEVATION

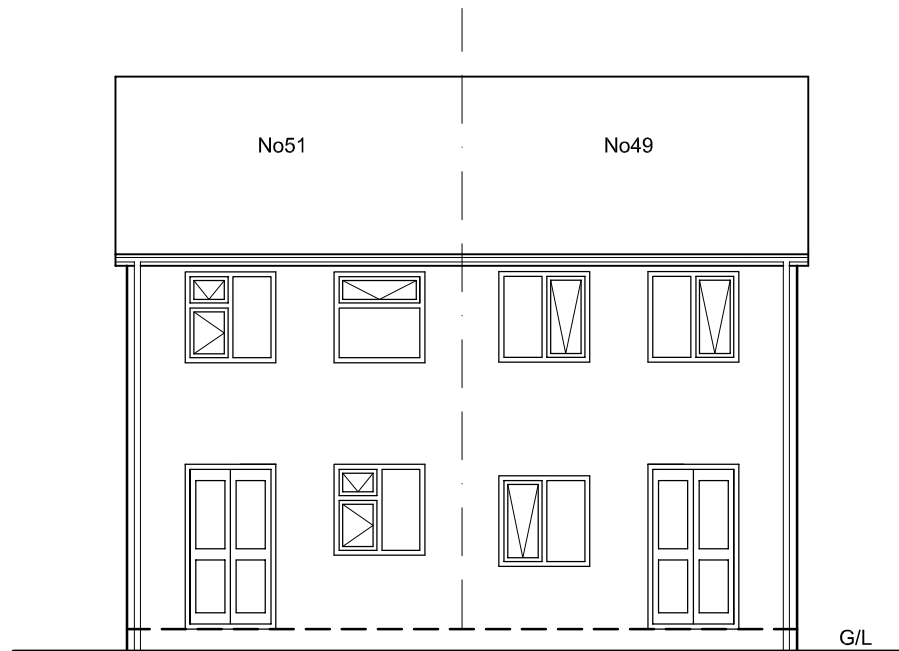

SOUTH ELEVATION

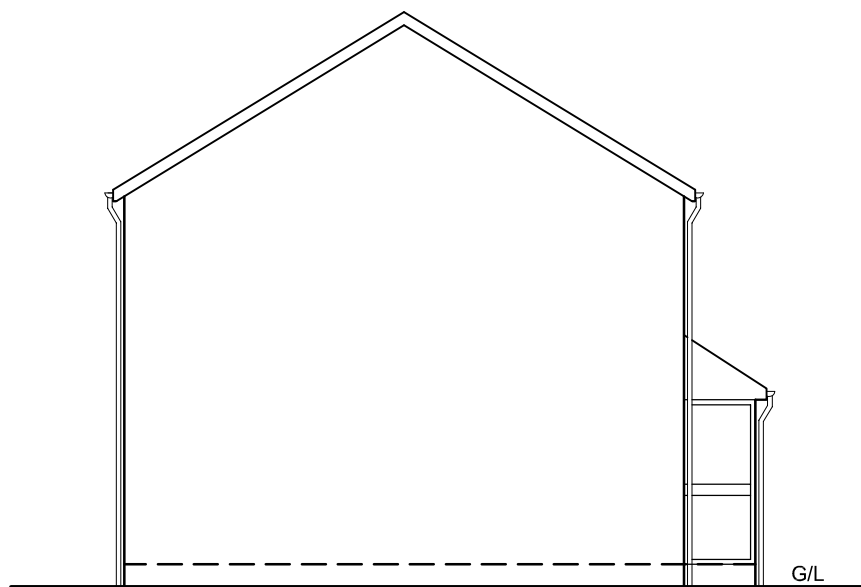

EAST ELEVATION

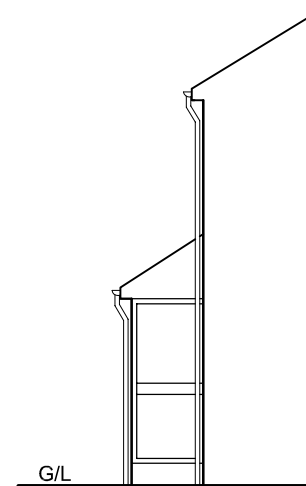

WEST ELEVATION

All dimensions and levels to be verified on site. Only figured dimensions to be used. Do not scale this drawing. Any discrepancies to be notified to the originator of the drawing immediately. If in doubt ask. Copyright reserved, the drawing is issued on the condition that it is not copied, reproduced, retained or disclosed to any unauthorized person either wholly or in part without consent.



NORTH LINCOLNSHIRE COUNCIL
 Home Improvement Team
 Neighbourhood and Environmental Services
 PO Box 42, Church Square House
 Scunthorpe, North Lincolnshire
 DN15 6XQ

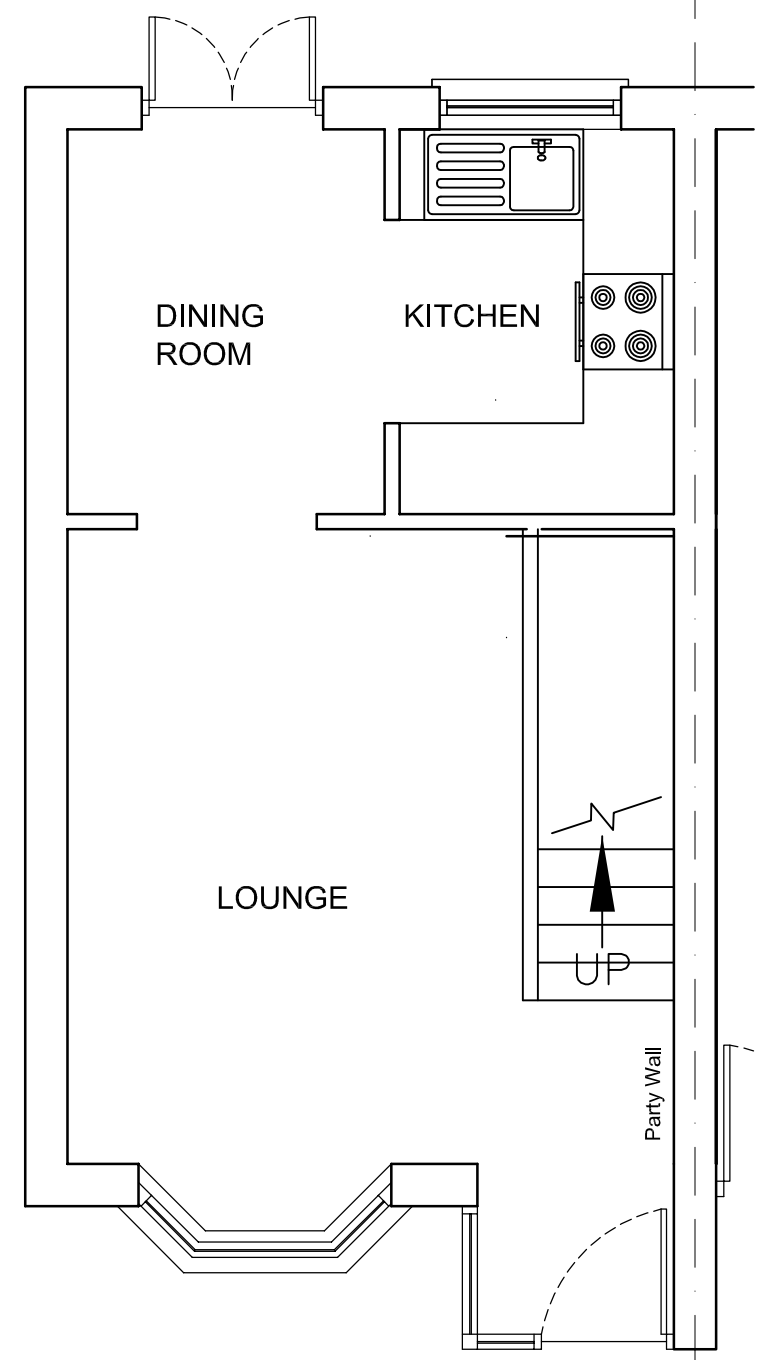

GROUND FLOOR

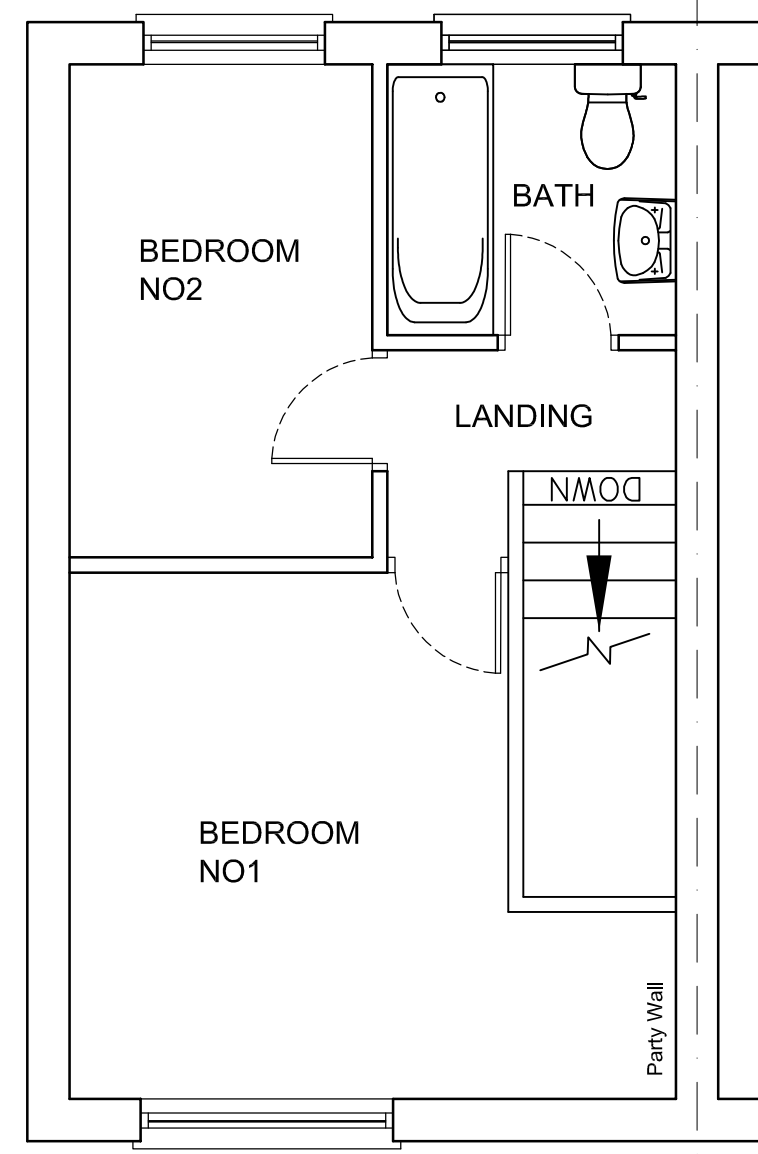

FIRST FLOOR

PRELIMINARY
 Notes:

Rev	Date	Comment
Rev A	11/10	Consultation issue

Disabled Adaptations for:
 Miss Mumby
 49 Townhill
 Broughton
 DN20 0HD

Drawing Title:
 Floor Plans Existing

Scale:
 1:50 @ A3

Drawn By:
 A Tutty

Drawing No:
 03

Date:
 November 2010

Revision: A	Checked:
----------------	----------

All dimensions and levels to be verified on site. Only figured dimensions to be used. Do not scale this drawing. Any discrepancies to be notified to the originator of the drawing immediately. If in doubt ask. Copyright reserved, the drawing is issued on the condition that it is not copied, reproduced, retained or disclosed to any unauthorized person either wholly or in part without consent.

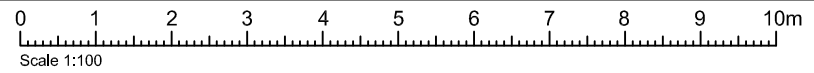

Home Improvement Team
Neighbourhood and Environmental
Services
PO Box 42, Church Square House
Scunthorpe, North Lincolnshire
DN15 6XQ

PRELIMINARY



NORTH ELEVATION



SOUTH ELEVATION

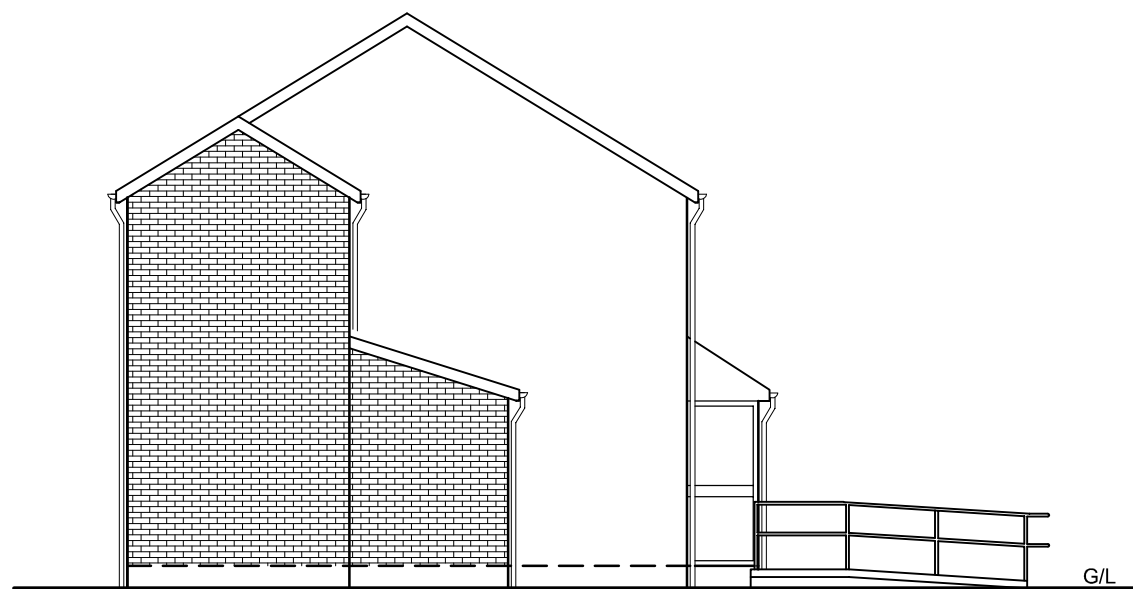

EAST ELEVATION

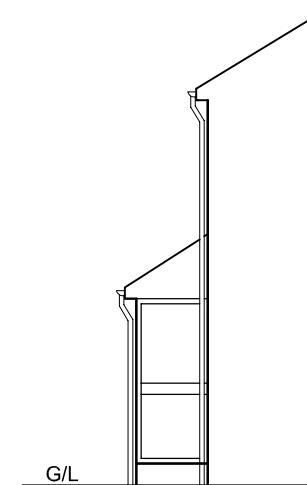

WEST ELEVATION

Rev	Date	Comment
Rev A	11/10	Consultation issue
Rev B	05/11	Extension width

Disabled Adaptations for:
Miss Mumby
49 Townhill
Broughton
DN20 0HD

Drawing Title:
Elevations - Proposed

Scale:
1:100 @ A3

Drawn By:
A Tutty

Drawing No:
04

Date:
November 2010

Revision: B	Checked:
----------------	----------

All dimensions and levels to be verified on site. Only figured dimensions to be used. Do not scale this drawing. Any discrepancies to be notified to the originator of the drawing immediately. If in doubt ask. Copyright reserved, the drawing is issued on the condition that it is not copied, reproduced, retained or disclosed to any unauthorized person either wholly or in part without consent.

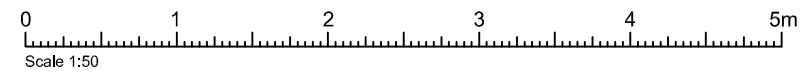

NOTE

Contractor to agree all setting out dimensions with the Contract Administrator on site and before the commencement of all construction work.

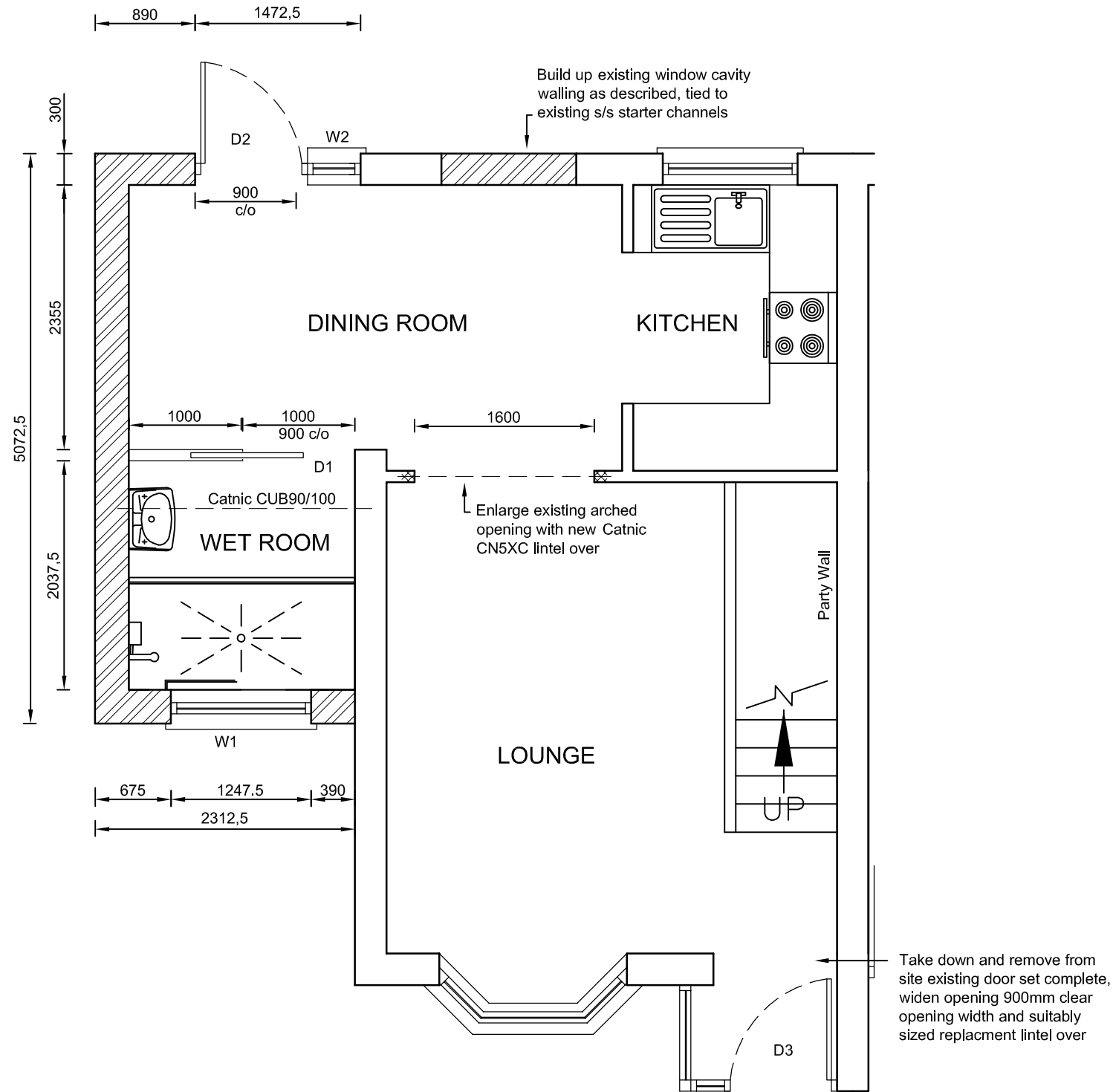

Home Improvement Team
Neighbourhood and Environmental Services
PO Box 42, Church Square House
Scunthorpe, North Lincolnshire
DN15 6XQ

PRELIMINARY

Notes:

Rev	Date	Comment
Rev A	11/10	Consultation issue
Rev B	01/11	Porch door
Rev C	05/11	Dimensions

Disabled Adaptations for:
Miss Mumby
49 Townhill
Broughton
DN20 0HD

Drawing Title:
Ground Floor Plan
Proposed

Scale:
1:50 @ A3

Drawn By:
A Tutty

Drawing No:
05

Date:
November 2010

Revision: C	Checked:
----------------	----------

All dimensions and levels to be verified on site. Only figured dimensions to be used. Do not scale this drawing. Any discrepancies to be notified to the originator of the drawing immediately. If in doubt ask. Copyright reserved, the drawing is issued on the condition that it is not copied, reproduced, retained or disclosed to any unauthorized person either wholly or in part without consent.



NOTE

Contractor to agree all setting out dimensions with the Contract Administrator on site and before the commencement of all construction work.



Home Improvement Team
Neighbourhood and Environmental Services
PO Box 42, Church Square House
Scunthorpe, North Lincolnshire
DN15 6XQ

PRELIMINARY

Notes:

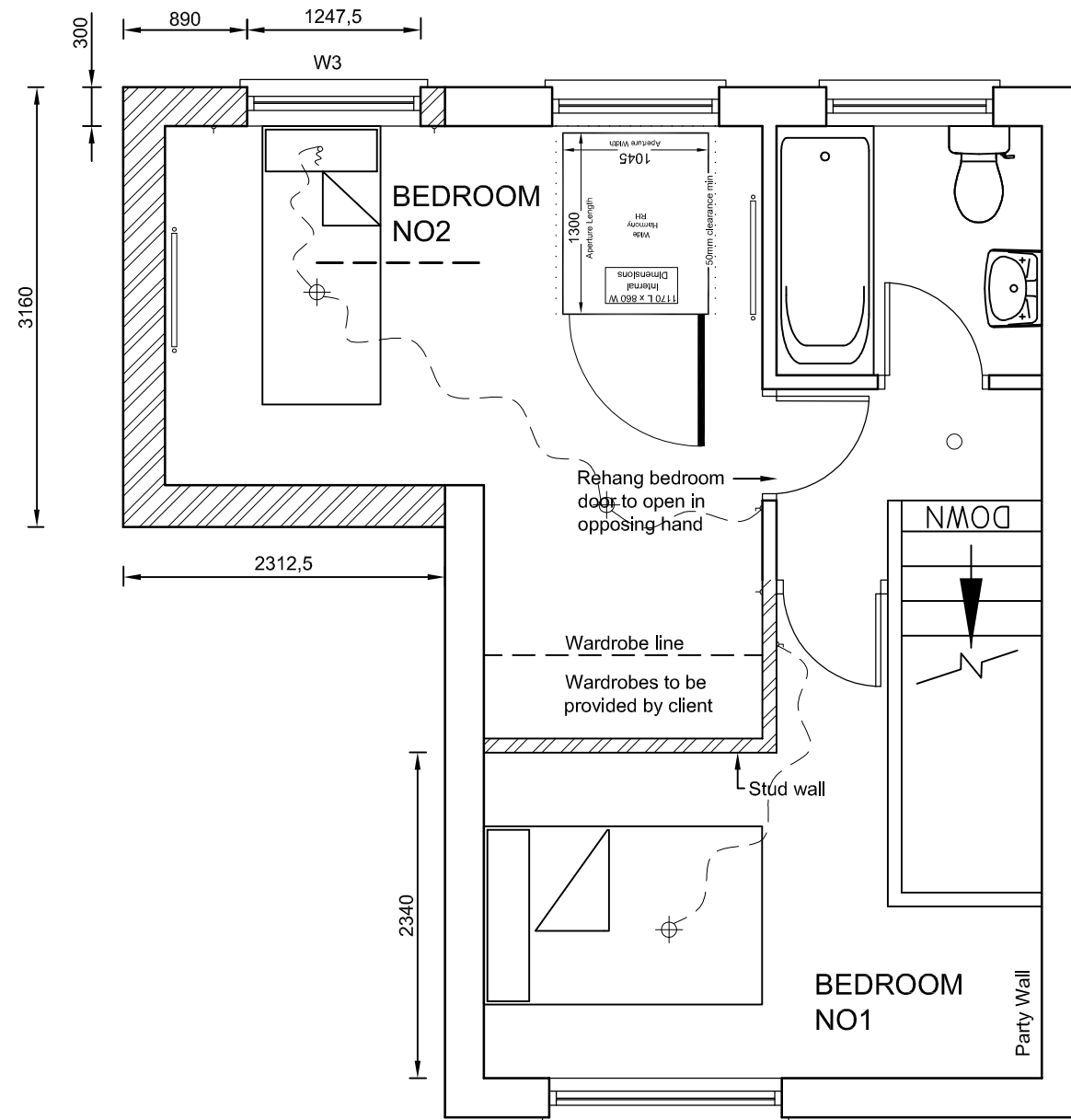

Rev	Date	Comment
Rev A	11/10	Consultation issue
Rev B	05/11	Dimensions

Disabled Adaptations for:
Miss Mumby
49 Townhill
Broughton
DN20 0HD

Drawing Title:
First Floor Plan
Proposed

Scale:
1:50 @ A3

Drawn By:
A Tutty

Drawing No:
06

Date:
November 2010

Revision: B	Checked:
----------------	----------