



User Manual for CN Boilers

Type

195

Machine no.

Date

CN Maskinfabrik A/S

Skovløkkevej 4, Tiset
6510 Gram, Denmark
Tel.: 74 82 19 19
Fax: 74 82 19 20

Version: April 2005

CONTENTS

Page 1.	Front page
Page 2.	Contents
Page 3.	Function
Page 4.	Dimensions
Page 5.	Rating plate / Boiler with Cooling Spiral / Responsibilities / Safety
Page 5.	Startup, Manual Stoking
Page 6.	Installation and Assembly Guide
Page 7.	Installation and Assembly Guide
Page 8.	Installation and Assembly Guide
Page 9.	Installation and Assembly Guide
Page 10.	Maintenance, Cleaning and Frost Protection
Page 11.	Technical Information. / Warranty Claims
Page 12.	Check List, End User
Page 13.	Check List, Supplier
Page 14.	Check List, CN MASKINFABRIK A/S.
Page 15.	Warranty Certificate, Customer Copy
Page 16.	5 Year Warranty Certificate CN MASKINFABRIK A/S.
Page 17.	Principle Diagram Overflow Valve / Cooling Spiral
Page 18.	Principle Diagram Open Expansion with Accumulation Tank.
Page 19.	Principle Diagram Pressure Expansion Without Accumulation Tank
Page 20.	Principle Diagram Open Expansion Without Accumulation Tank.
Page 21.	Principle Diagram Open Expansion Without Accumulation Tank.

Accessories supplied with the boiler

1. Probe (dip pipe, valve, sensor)
2. Cleaning brush
3. Scraping tool



All CN boilers must be installed according to the Installation and Assembly Guide below.

If the boiler is not installed in accordance with the installation instructions in the user manual, it is the responsibility of the installation engineer to submit the boiler unit to a construction test (module B1) or install the boiler unit in accordance with a system of full quality assurance (module H) according to the Pressure Equipment Directive 97/23/EEC. In both cases, an authorised body after your own choice must be contacted.

Function

- The CN boiler is a triple-flue boiler constructed on the basis of many years' experience and testing.
- The CN boiler is constructed with a large cylindrical fire chamber, specially developed for firing with stoker, wood, wood chips, saw dust, peat, paper, coal or coke etc.
- The convection part of the CN boiler is placed on top of the fire box in the hottest part of the boiler, which consists of many smoke gas sections surrounded by water.
- The construction and dimensions of the CN boiler thus create an efficient use of the smoke gas before it reaches the smoke outlet
- The large doors of the CN boiler, which open both the fire chamber and the smoke ducts, make cleaning the boiler very efficient and easy.
- Optimal, environmentally friendly and highly efficient burning of the wood requires correct ratio between the combustion air and the smoke gasses from the fuel.
- The boiler is constructed with a large door to enable the burning of large objects.
- Acidifying substances such as plastic (PVC) must not be burned in the boiler, as they produce hydrochloric acid fumes during combustion (HCL).
- Basifying substances must not be burned in the boiler, as they corrode the boiler during combustion.
- It is important that the feeding of fuel is adjusted to allow the heat from the wood to be contained in the heat reservoir at all times. The stoking should be adjusted so that the fuel has just been burned when the heat reservoir reaches its maximum temperature.
- The boiler efficiency is larger when the boiler can deliver the heat without having to shut off the air supply too much.

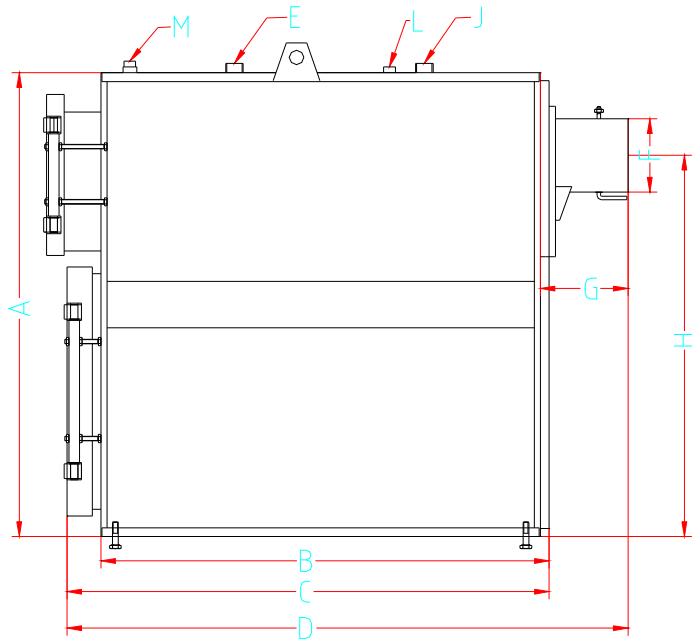

Key			CN 195
A		mm	1900
B		mm	2260
C		mm	2410
D		mm	2720
E	Return pipe	mm	2½"
F	Smoke outlet	mm	250
G		mm	310
H		mm	1620
I		mm	1225
J	Supply / Return	inches	2½"
L	Expansion vessel	inches	1"
M	Flue regulator	inches	1"

Yield wood	kW	
Yield automatic stoking	kW	195
Heat surface	m2	18,86
Volume fire chamber	m2	1.7
Test pressure	bar	3
Water content	litre	860
Fire box diameter	mm	970
Fire box depth	mm	2300



Boiler with cooling spiral

Boilers can be ordered with a cooling spiral, and this must be used for installation with pressure expansion, and in open systems if the pressure in the boiler is above 0.5 bar over pressure. The cooling spiral must only be used as a cooling spiral; it must not be used for heating up water for other use. Therefore the cooling spiral must be left empty during operation. Water supply for cooling spiral maximum 15 °C. Pressure for cooling spiral minimum 2 bar, maximum 10 bar.

Responsibilities

The user is responsible for the operation of the boiler and ensuring compliance with the operational guidelines supplied by CN MASKINFABRIK A/S. Failure to comply with the guidelines may result in reduced efficiency and increased negative effects on the environment, as the boiler will not achieve as clean emission gasses as intended. Furthermore, incorrect operation can reduce the working life of the boiler. Correct operation and installation are the best guarantees for a well-functioning boiler with a long life and a good environment. The user needs to have the necessary willingness and correct attitude to burning wood, as it does, after all, take a bit of work to "yield the crops" of this environmentally friendly and financially profitable type of heating

Safety

If any faults or failures are found, they must be repaired as soon as possible by a boiler engineer. Flue pipes, ventilation ducts, air holes etc. must not be closed off or blocked. Flammable liquids or combustible substances must not be placed in dangerous proximity to the boiler.

For systems with an operational pressure above 0.5 bar over pressure (closed system with pressure expansion or open system where the height from the boiler to the highest water surface is more than 5 meter), the boiler must be equipped with a cooling spiral connected to a cold water supply.

Boilers equipped with a cooling spiral must not be used (should be switched off) if the water supply is out of order, or the water supply to the boiler is shut off (e.g. on the main tap).

Startup, manual stoking

1. Fill the boiler with the required amount of combustible material.
2. Light the fuel from below.
3. Adjust the air supply hatches (only until the right air supply level is found) only during manual stoking without stoker.
 - **Note.** Be very careful when opening the door to the boiler during operation due to extreme heat inside the boiler and smoke emission.

Stop: When the fuel material has been burned, the heat supply from the boiler stops.

Installation and Assembly Guide:

Norms and Directions

- It is the responsibility of the installation engineer that he has the necessary training and authorisation to install the boiler. The size of the boiler should be based on the heating needs of the house rather than the size of the fuel container.
The installation must fulfill the requirements described in the directions of the Health and Safety at Work Act 1974, including the following regulations: The Electricity at work Regs 1989, The Provision and Use of Work Equipment Regs 1998, The Personal Protective Equipment Regs 1992, The Fire Precautions (Workplace) (Amendments) Regs 1999, The construction Design and Management Regs 1994. Current Institute of Electrical Engineers regulations. "The Pressure Equipment Directive 97/23/EEC" and UK Building Regulations 2000 (as amended). See in particular the following approved documents:
A: structure 2004 + amendments
B: fire safety 2000 edition + amendments
F: ventilation 2006 edition
J: combustion appliances and fuel storage systems 2002 edition
J: Guidance and supplementary information on the UK implementation of European standards for chimneys and flues 2002 edition
L1A; L1B; L2A;L2B: Conservation of fuel and power 2006 edition.
M: Access to and use of buildings 2004 edition
P: Electrical Safety – Dwellings – 2006 edition
- If the boiler is used for burning straw, the installation must furthermore fulfill the requirements described in the specific directions of The Health and Safety at Work Act 1974
- All smoke pipes must have an uphill gradient of minimum 1 %, and all joints must be tight. Never use a smaller diameter smoke pipe as the boiler outlet pipe. Always use elbows with a bending and flap as bent joints, as they provide the best flue. **All smoke pipes must be insulated, also when the boiler is used with stoker feeding.**
- The combustion must not be carried out until the boiler is installed and fully connected.
- A probe must always be installed on the boiler, and the return pipe (pages 9/11) must always be minimum 60° C during operation. See the assembly guide drawing.
- If the right physical conditions are present, the boiler may be installed on a base (approximately 400 mm high) to make the operation and removal of ashes easier.

Open or closed system

- CN boilers type 80 and type 120 are approved for installation as open or closed systems.
- When used as a closed system (with pressure expansion) and open system with a height above 5 meters, the boiler must be equipped with a cooling spiral and a thermal over temperature valve (pages 7 & 8).

Safety valve requirements in closed systems

- With boilers > 60 kW every boiler must have at least 2 safety valves. The safety valves must be able to, in combination at the chosen blow-off pressure, blow off at least 1.5 times the boiler heat yield in the form of steam. They must, however, have a minimum internal diameter of 20 mm.
- The inlet and outlet hoses of the safety valves must be of sufficient dimensions for the capacity of the safety valves not to be noticeably reduced. The inlet pipe must not contain blocking devices, pumps, boiler mountings, restrictions or water sacks.
- All inlet and outlet hoses to and from safety valves must be run through pipes approved for 120 °C and minimum 10 bar over pressure.

Safety hose open systems (open expansion)

- All the system boilers must have a connection to the atmosphere through a safety hose which cannot be blocked.
- Safety hoses must depart from the top of the system boiler(s). They must run at an uphill gradient to the open expansion vessel and from there run at a steady downhill gradient, at a suitable distance from a drain and in such a way that the outlet of hot water does not result in a risk of injury. The outlet point must be cut at an angle.
- At the highest point of the safety hose there must be an internal diameter of minimum 15 mm as a siphon break.
- The vertical distance from the highest point of the system to the boiler must not exceed 10 meters.
- The total length of the safety hose must not exceed 20 meters.
- For boilers > 60 kW the safety hose must have a minimum internal diameter of 35.5 mm
- All pipes must be approved for 120 °C and minimum 10 bar over pressure.

For installation with operational pressure >0.5 bar and open expansion principle diagram pages 17 & 20 must be used

- If the operational pressure of the boiler exceeds 0.5 bar over pressure, the boiler unit (the installed boiler including fittings and safety equipment) is covered by the Pressure Equipment Directive 97/23/EEC "Installation of pressurised equipment", which requires that the boiler unit must fulfil certain essential safety requirements regarding the safety equipment of the boiler etc. **The boiler must be fitted with a cooling spiral**
- **Expansion vessel:** The vessel must be installed in accordance with the directions of The Health and Safety at Work Act 1974.
- The bottom of the expansion vessel should be installed only above pipes/radiator of the central heating system and with an open expansion vessel. Block valves must under no circumstances be placed between the boiler and the expansion vessel. **There must under no circumstances be any circulation in the expansion vessel.**

The boiler must be installed with pos. nos. 1, 2, 3, 4, 5, 7, 9, 10, 13 (drawings pages 17 & 20)

Description	Type / Requirements	Draw. Pos no.	Supplier
Shunt valve	TA type TRV 300	1	CN (supplied)
Oper. thermostat	BC components type NTC-2322	2	CN (supplied with stoker)
Overheat. thermostat	Honeywell type L6188	3	CN (supplied with stoker)
Boiler thermometer	0-120 degrees	4	Installation engineer
Pressure gauge (manometer)	0-3 maximum 5 bar, red mark at 2.5 bar	4	Installation engineer
Expansion vessel	CE labeled, minimum 8 % of total system water volume	5	Installation engineer
Safety valve CE approved	2 pces., 2.5 bar, clearance minimum 20 mm	7	Installation engineer
Cooling spiral CN80:	Wieland heat exchanger type WRK 13	9	CN (supplied)
Cooling spiral CN120:	Wieland heat exchanger type WRK 13	9	
Safety thermostat	Honeywell type TS130, CE approved	10	CN
Water shortage protection	RT 200 Pressostat	13	Installation engineer

For installation with operational pressure >0.5 bar and pressure expansion, principle diagram pages 17 & 19 must be used

- If the operational pressure of the vessel exceeds 0.5 bar over pressure, the boiler unit (the installed boiler including fittings and safety equipment) is covered by the Pressure Equipment Directive 97/23/EEC "Installation of pressurised equipment", which requires that the boiler unit must fulfill certain essential safety requirements regarding the safety equipment of the boiler etc. **The boiler must be fitted with a cooling spiral amongst other things**

The boiler including fittings and safety equipment must be installed in accordance with the principle diagrams on pages 17 and 19. The engineer must test the safety equipment in accordance with the section "Testing the safety equipment" before the system is handed over to the user. The following fittings and safety equipment etc. must, in accordance with the above-mentioned principle diagrams, be installed in the boiler unit in order to be covered by the CN Maskinfabrik A/S Construction Test Certificate:

The boiler must be installed with pos. nos. 1, 2, 3, 4, 6, 7, 9, 10, 13 (drawings pages 17 & 19)

Description	Type / Requirements	Draw. Pos nos.	Supplier
Shunt valve	TA type TRV 300	1	CN (supplied)
Oper. thermostat	BS components type NTC-2322	2	CN (supplied with stoker)
Overheating thermostat	Honeywell type L6188	3	CN (supplied with stoker)
Boiler thermometer	0-120 degrees	4	Installation engineer
Pressure gauge (manometer)	0-3 maximum 5 bar, red marks at 2.5 bar	4	Installation engineer
Pressure expansion vessel	CE labeled minimum 4 % of total system water volume (see table below)	6	Installation engineer
Safety valve CE approved	2 pces., 2.5 bar, clearance minimum 20 mm	7	Installation engineer
Cooling spiral			CN (supplied)
CN 80:	Wieland heat exchanger type WRK 13	9	
CN120:	Wieland heat exchanger type WRK 13	9	
Safety thermostat	Honeywell type TS130, CE approved	10	CN (supplied with stoker)
Water shortage protection	RT 200 Pressostat	13	Installation engineer

NOTE:

- The system must have a membrane type expansion vessel with airbag. The expansion vessel must have a durable and solidly fastened rating plate which clearly states Manufacturer, Volume in litres, Test Pressure in bar and Initial Pressure in bar
- The expansion hose between the expansion vessel and the rest of the system must not be less than 25mm.
- **Safety valve:** The safety valve must be installed in accordance with the directions of The Health and Safety at Work Act 1974.
- **Expansion vessel: Expansion vessels:** The vessel must be installed in accordance with the directions of The Health and Safety at Work Act 1974.
-

Size of expansion vessel closed system:

Calculation of pressure expansion
Water expansion in % from 10 °C

Average temperature °C	%
60	1.7
70	2.3
80	3.0
90	3.6
100	4.4
110	5.2
120	6.0

Maximum system temperature °C	90 °C
Water content heating system Boiler (type 25) 180 L. Installation 350 L.	530 L.
Water exp. (530x3,6/100)	19.08
Expansion vessel efficiency	57 %
Size expansion vessel (19.08x100/57)=33.47=	34 L.

Expansion vessel efficiency
in % after initial and operational pressure

Example of calculation (new systems)

In. pres.	Oper. pressure bar			
	1.0	1.5	2.0	2.5
0.5	25	40	50	57
1.0		20	33	42
1.5			16	28
2.0				14

For boilers with open expansion and operational pressure < 0.5 bar, the principle diagram pages 18 & 21 must be used

If the operational pressure of the boiler is below 0.5 bar, the boiler must be installed in accordance with the directions of The Health and Safety at Work Act 1974 about combustion hot water systems. **Cooling spiral is not required.** The bottom of the expansion vessel should be installed above the highest pipe/radiator of the central heating system and with an open expansion vessel. Block valves must under no circumstances be placed between the boiler and the expansion vessel. **There must under no circumstances be any circulation in the expansion vessel.**

Size of expansion vessel open system:

The expansion vessel must be at least 8 % of water content (boiler + reservoirs + pipes and radiators) acc. to Btv32.

Boilers exclusively used for manual stoking must be installed with following pos. nos. 1, 4, 5, 11, 12 (draw. page 18)

Boilers used with stoker pos. nos. 1, 2, 3, 4, 5 (draw. page 21)

Description	Type / Requirements	Draw. Pos no.	Supplier
Expansion vessel	CE labeled, minimum 8 % of total system water volume	5	Installation engineer
Oper. thermostat	BS components type 2322	2	CN (supplied with stoker)
Overheat. thermostat	Honeywell type L6188	3	CN (supplied with stoker)
Boiler thermometer	0-120 C° degrees	4	Installation engineer
Pressure gauge (manometer)	0-3 maximum 5 bar, red mark at 2.5 bar	4	Installation engineer
Accumulation tank	Type approved in acc. with "Declaration on Installation of Pressurised Equipment"	11	Installation engineer
Shunt valve	TA type TRV 300	1	CN (supplied)
Flue regulator	1" Robust	12	Installation engineer

Testing the safety equipment.

The engineer must test the safety equipment before the unit is handed over to the user.

- The engineer must check that the operation thermostat is working.
- The engineer must also check the overheating protection.
This is done by removing the overheating thermostat from the dip pipe and placing it in boiling water. The thermostat should now cut out and the system stop. Reset the thermostat once the temperature has fallen, and place it back in the dip pipe.
- The engineer must also check that the safety valves open at max 2.5 bar.
- The engineer must test the operation of the thermal valve for the cooling spiral. The valve should open at a sensor temperature of maximum 95 °C. Remove the sensor from the dip pipe and place it in boiling water. Check that water now flows through the cooling spiral. Replace the sensor in the dip pipe.

- When installing Water shortage protection Type RT 200 Pressostat, the installation engineer must adjust the pressostat so that it stops the system, when the operational pressure is below 0.5 bar over pressure. Furthermore, the installation engineer must test that the pressostat physically stops the system when the operational pressure < 0.5. This is done by filling the system to more than 0.5 bar over pressure, starting the system and shut off the water supply until the system stops; this should happen at 0.5 bar over pressure.

Maintenance and cleaning:

- The closing mechanisms of the door and cleaning hatch are adjusted from the factory but must be inspected for correct sealing after a month of use, when the gasket has "settled".
- If any irregularities are found in the safety valve(s), expansion vessel or automatics of the unit, the owner/user must immediately have the equipment in question inspected and repaired by an authorised engineer. The owner/user must ensure that any installed safety valves are not blocked by scale etc. It is the responsibility of the owner/user that the boiler and any equipment is cleaned and maintained according to:
- Normal practice,
- The boiler flue system is cleaned by opening the top hatch of the boiler. The many flue pipes placed at the top of the boiler should be cleaned every 3 days with the round cleaning brush/cleaning tool supplied with the boiler. Push the brush all the way through; take care not to damage the bottom tile in the smoke box. Pull the brush / cleaning tool back out; repeat several times for each pipe. After cleaning, empty the smoke box at the back of the boiler. The boiler must always be switched off during cleaning. Clean smoke pipes and smoke box result in more economical operation.
- The boiler combustion chamber should be cleaned every 24 hours (of use).
- If the boiler is switched off for a long period (approximately 1 week), the boiler and flue pipes should be cleaned thoroughly, as the residue combined with damp results in corrosion.
- The pump(s) must be switched off whilst the system is filled up with water
- **NOTE: Do not fill up an overheated boiler with water.**
- Installation with pressure expansion: water filling until 1.5-2.0 bar.
- Installation with open expansion: water filling until the water runs out of the expansion vessel overflow.
- **Testing the safety valves:** It is the responsibility of the user that the installed safety valves are tested twice annually. This is done by pressing or turning the valve test device. By doing this you are able to see and hear a bit of water being released and thereby confirm that the valve is operational. Damages caused by a blocked safety valve are not covered by the warranty issued by CN MASKINFABRIK A/S.
- Safety valves are installed in connection with the central heating unit (2.5 bar) and possibly in connection with the hot water circuit (6 bar or 10 bar). Please ask your installation engineer if in doubt about the location of the valves.
- After 300 hours' operation, nuts and bolts must be tightened and doors adjusted!

Replacing the glass string in doors

- Open the door. Remove the old gasket, if necessary with a chisel or a screw driver. Clean the gasket groove. Push the new gasket into the groove. Put the last end in place when this is about half done, and then the rest. Bang the string lightly with a hammer if necessary.

Frost protection:

- During normal operation above freezing point there is no need for frost protection.
- The central heating unit can be protected with anti-freeze solution. Remember, however, that the hot water container, if relevant, is not protected against frost.
- When stopping the unit at an ambient temperature below zero, the boiler must be emptied of water. This is done by running a hose from the bottom tap of the boiler to a drain in the floor and opening the tap.

Technical information CN195 boiler installed with 195 kW CN Stoker

- Smoke gas temperature 195 boiler at nominal yield with wood pellets: ~160 °C
- Smoke gas temperature 195 boiler at 20 % yield with wood pellets: ~83 °C
- Smoke gas mass flow 195 boiler at nominal yield: ~229 kg/h
- Smoke gas mass flow 195 boiler at partial load 20 % yield: ~88 kg/h
- Nominal yield 195 boiler in nearest whole kW with wood pellets: ~195 kW
- Yield range 195 boiler 20 % -100 %: ~46 - ~195kW
- Required flue 195 boiler ~14 Pa
- Chimney must have an internal diameter of minimum 250mm and be of an approved type.
- The boiler thermostat setting range is 55-85 °C
- Water content in 195 boiler: 860 L.
- Boiler classification:
- Set point for boiler thermostat: 65 °C

Warranty Claims

CN MASKINFABRIK A/S provides a 24 month warranty for the stoker unit following the date of this user manual for the first user.

The warranty includes materials and manufacturing faults, but not wear on parts, damages caused by failure to maintain the unit, incorrect use or overloading.

Claims will be compensated based on the price of the spare parts or repair, if this is cheaper. Labour wages according to an hourly labour rate for normal working hours as specified by CN MASKINFABRIK A/S.

The warranty does not cover transport, freight, consequential damages and operational losses.

This warranty is not valid until CN MASKINFABRIK A/S has received the check list on p. 14.

CHECK LIST

User manual received

I have received instructions in the use of the boiler,
including what fuel material may be fed to the boiler.

I have received instructions in the maintenance of the boiler

Boiler type :

Serial number:

Year

I hereby declare that I have understood the received material.

Name : _____

Address : _____

Town and post code: _____

Signature

For:

End user

CHECK LIST

User manual received

I have received instructions in the use of the boiler,
including what fuel material may be fed to the boiler.

I have received instructions in the maintenance of the boiler

Boiler type :

Serial number:

Year

I hereby declare that I have understood the received material.

Name:

Address:

Town and post code:

Signature

Please return to:

Supplier

CHECK LIST

User manual received

I have received instructions in the use of the boiler,
including what fuel material may be fed to the boiler.

I have received instructions in the maintenance of the boiler

Installation carried out by : _____

Signature

Please check below

The installation was carried out in accordance with the Installation and Assembly Guide in the user manual and is thus covered by the CN MASKINFABRIK A/S Construction Test Certificate _____

The installation engineer has subjected the boiler unit to a construction test (module B1) or installed the boiler unit in accordance with a full quality assurance system (module H) in accordance with the Pressure Equipment Directive 97/23/EEC. _____

Boiler type :

Serial number:

Year

I hereby declare that I have understood the received material.

Name:

Address:

Town and post code:

Signature

Please return to: CN MASKINFABRIK A/S,
Skovlørkevej 4,
Tiset
6510 Gram,
Denmark

This warranty only comes into force when CN MASKINFABRIK A/S has received this page signed

by the customer and the installation engineer

Warranty Certificate

(Customer copy)

CN MASKINFABRIK A/S provides a 5 year warranty for penetrating corrosion of the boiler if the following points are adhered to.

- 1. The warranty certificate on page 14 is signed, returned and complied with**
- 2. All points of the user manual are complied with**
- 3. The unit is serviced minimum once a year by CN MASKINFABRIK A/S or a company approved by CN MASKINFABRIK A/S.**
- 4. The check list on page 12 is returned to CN MASKINFABRIK A/S**
- 5. The boiler must a no time have been used for burning grain.**
- 6. The boiler must not be exposed to insufficient maintenance, incorrect use or overloading.**
- 7. CN MASKINFABRIK A/S will repair any claims or approve the repair before it is carried out according to the choice of CN.**

The service includes the following:

- Gaskets inspected and checked.
- Doors inspected, tightened and adjusted.
- Boiler cleaned and inspected
- Installation inspected.
- Smoke pipe inspected and checked
- Any fire resistant materials inspected and checked
- Cleaning tools inspected and checked.
- The boiler must be cleaned prior to service

Serial number: _____ Date: _____

Signature: _____

Warranty Certificate

CN MASKINFABRIK A/S provides a 5 year warranty for penetrating corrosion of the boiler if the following points are adhered to.

- 1. The warranty certificate on page 14 is signed, returned and complied with**
- 2. All points of the user manual are complied with**
- 3. The unit is serviced minimum once a year by CN MASKINFABRIK A/S or a company approved by CN MASKINFABRIK A/S.**
- 4. The check list on page 12 is returned to CN MASKINFABRIK A/S**
- 5. The boiler must a no time have been used for burning grain.**
- 6. The boiler must not be exposed to insufficient maintenance, incorrect use or overloading.**
- 7. CN MASKINFABRIK A/S will repair any claims or approve the repair before it is carried out according to the choice of CN.**

The service includes the following:

- Gaskets inspected and checked.
- Doors inspected, tightened and adjusted.
- Boiler cleaned and inspected
- Installation inspected.
- Smoke pipe inspected and checked
- Any fire resistant materials inspected and checked
- Cleaning tools inspected and checked.
- The boiler must be cleaned prior to service

Please return this page to: CN MASKINFABRIK A/S

Skovlækkevej 4 Tiset
6510 Gram, Denmark

Name : _____
Address : _____
Town : _____ Post code: _____
Tel.: : _____
Serial number: _____ Date: _____

Signature: _____

This drawing is a principle diagram.
Hence, CN Maskinfabrik A/S cannot be
made responsible for faults, errors or
losses based on this diagram.

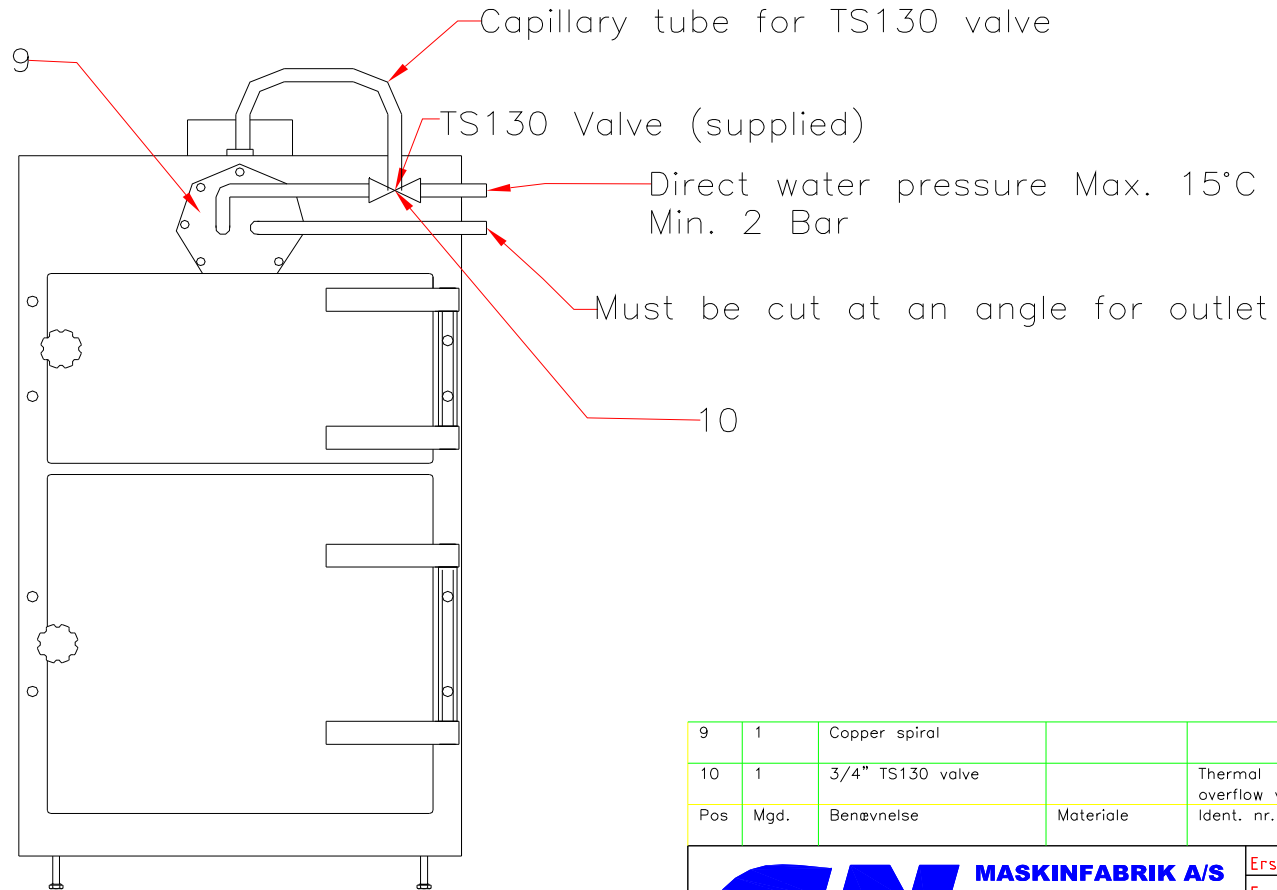

9	1	Copper spiral			Supplied with boilers ordered with cooling spiral
10	1	3/4" TS130 valve		Thermal overflow valve	Supplied with boilers ordered with cooling spiral
Pos	Mgd.	Benævnelse	Materiale	Ident. nr.	Bemærkning

 MASKINFABRIK A/S Skovløkkevej 4, Tiset 6510 Gram Tlf. 74 82 19 19	Erstattet dato:		
	Erstatning for:		
Emne: Installation guide Overflow valve	Dato: 20/2-2003		
	Tegnet af: PS	Målførhold:	Format: A4
	Tegn. nr.: Page 17		Version: 1

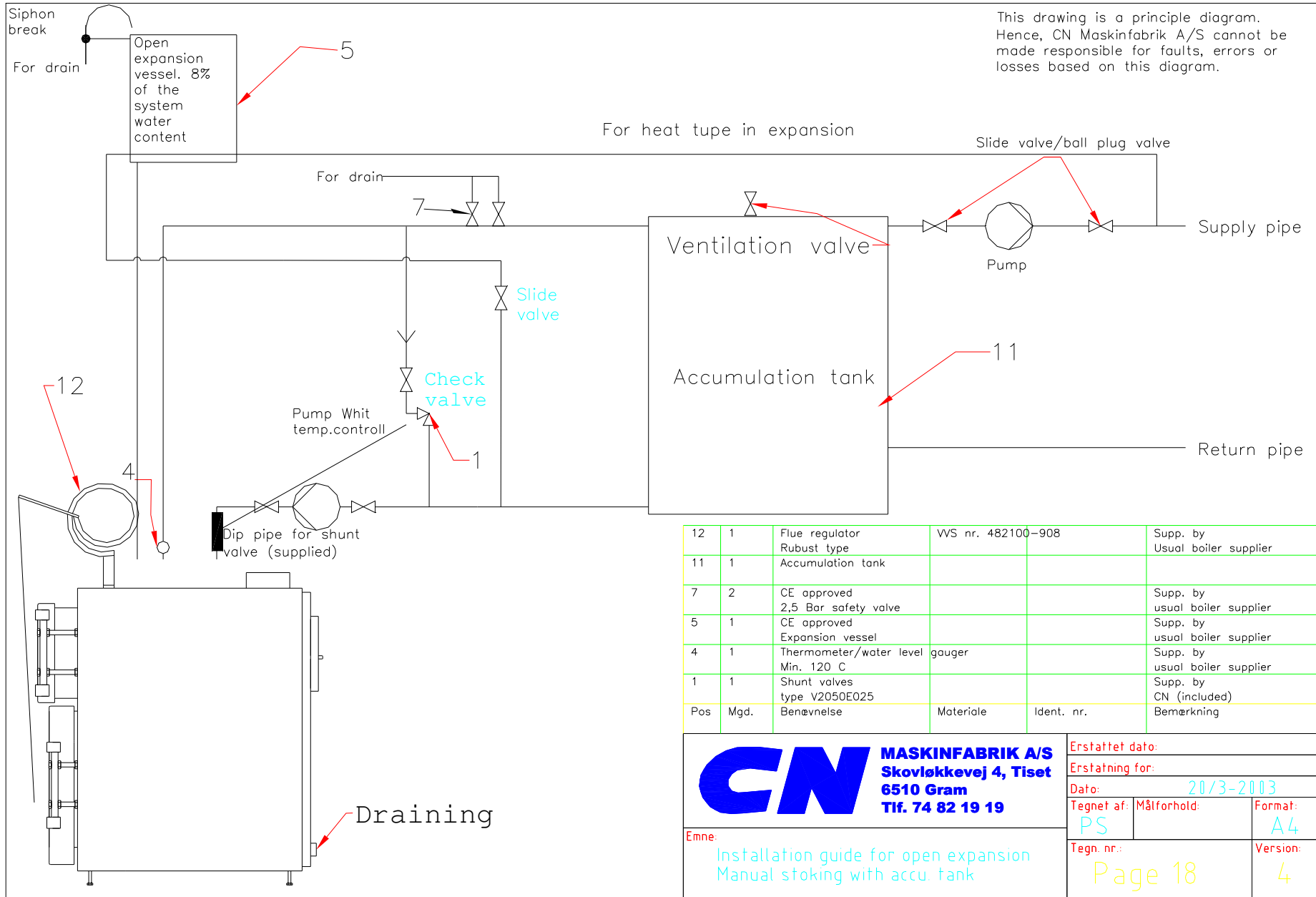

12	1	Flue regulator Rubust type	WVS nr. 482100-908		Supp. by Usual boiler supplier
11	1	Accumulation tank			
7	2	CE approved 2,5 Bar safety valve			Supp. by usual boiler supplier
5	1	CE approved Expansion vessel			Supp. by usual boiler supplier
4	1	Thermometer/water level gauger Min. 120 C			Supp. by usual boiler supplier
1	1	Shunt valves type V2050E025			Supp. by CN (included)
Pos	Mgd.	Benevnelse	Materiale	Ident. nr.	Bemærkning

CN MASKINFABRIK A/S
 Skovløkkevej 4, Tiset
 6510 Gram
 Tlf. 74 82 19 19

Emne: Installation guide for open expansion Manual stoking with accu. tank

Erstattet dato:		
Erstatning for:		
Dato:	20/3-2003	
Tegnet af:	Målforhold:	Format:
PS		A4
Tegn. nr.:	Version:	
Page 18	4	

This drawing is a principle diagram. Hence, CN Maskinfabrik A/S cannot be made responsible for faults, errors or losses based on this diagram.

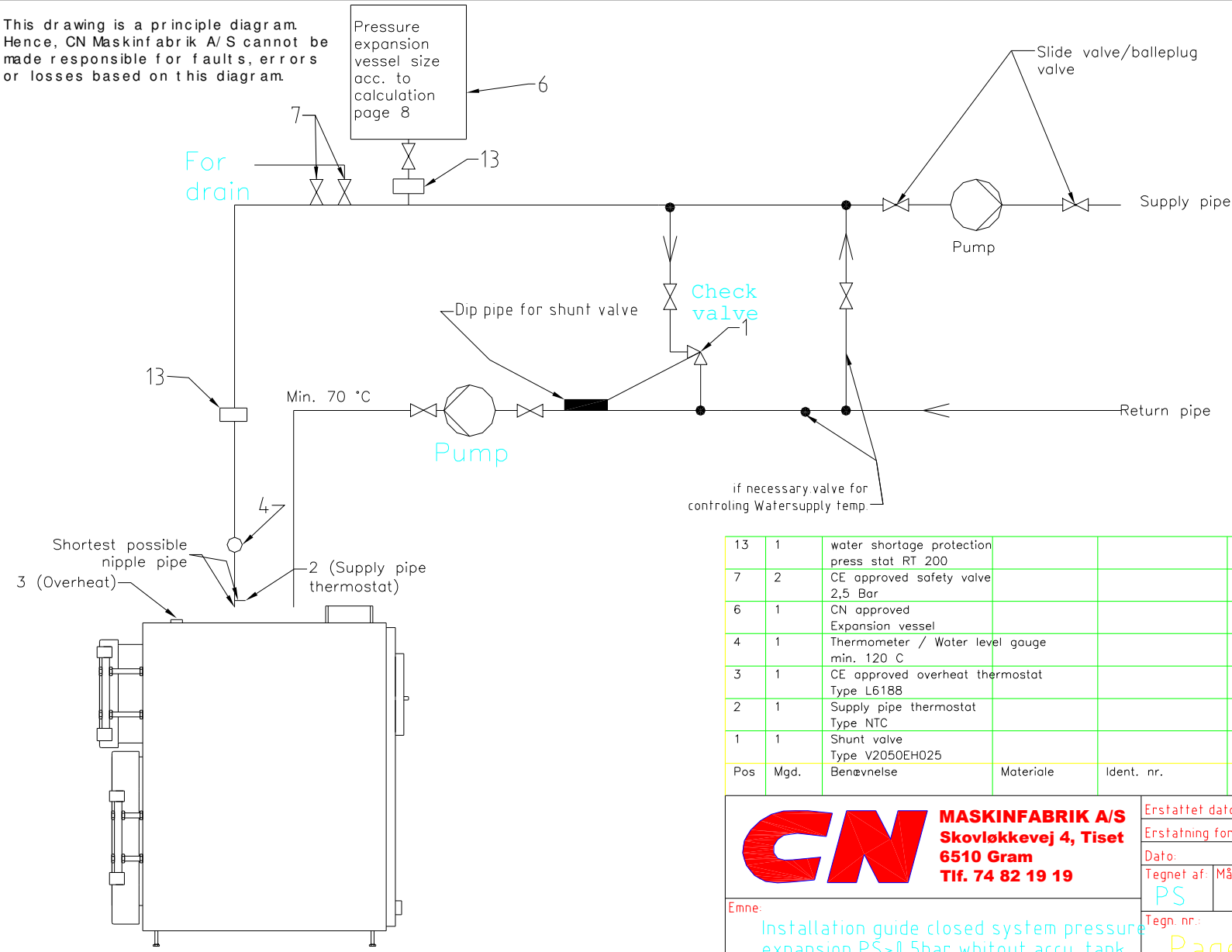

13	1	water shortage protection press stat RT 200			Supp. by usual boiler supplier
7	2	CE approved safety valve 2,5 Bar			Supp. by usual boiler supplier
6	1	CN approved Expansion vessel			Supp. by usual boiler supplier
4	1	Thermometer / Water level gauge min. 120 C			Supp. by usual boiler supplier
3	1	CE approved overheat thermostat Type L6188			Supp. whit CN Stoker
2	1	Supply pipe thermostat Type NTC			Supp. whit CN Stoker
1	1	Shunt valve Type V2050EH025			supp. by CN (included)
Pos	Mgd.	Benevnelse	Materiale	Ident. nr.	Bemærkning

CN MASKINFABRIK A/S
 Skovløkkevej 4, Tiset
 6510 Gram
 Tlf. 74 82 19 19

Erstattet dato:		
Erstatning for:		
Dato:	1/4-2005	
Tegnet af:	Målforhold:	Format:
PS		A4
Tegn. nr.:	Version:	
Page 19	5	

Emne: Installation guide closed system pressure expansion PS>0,5bar whitout accu. tank

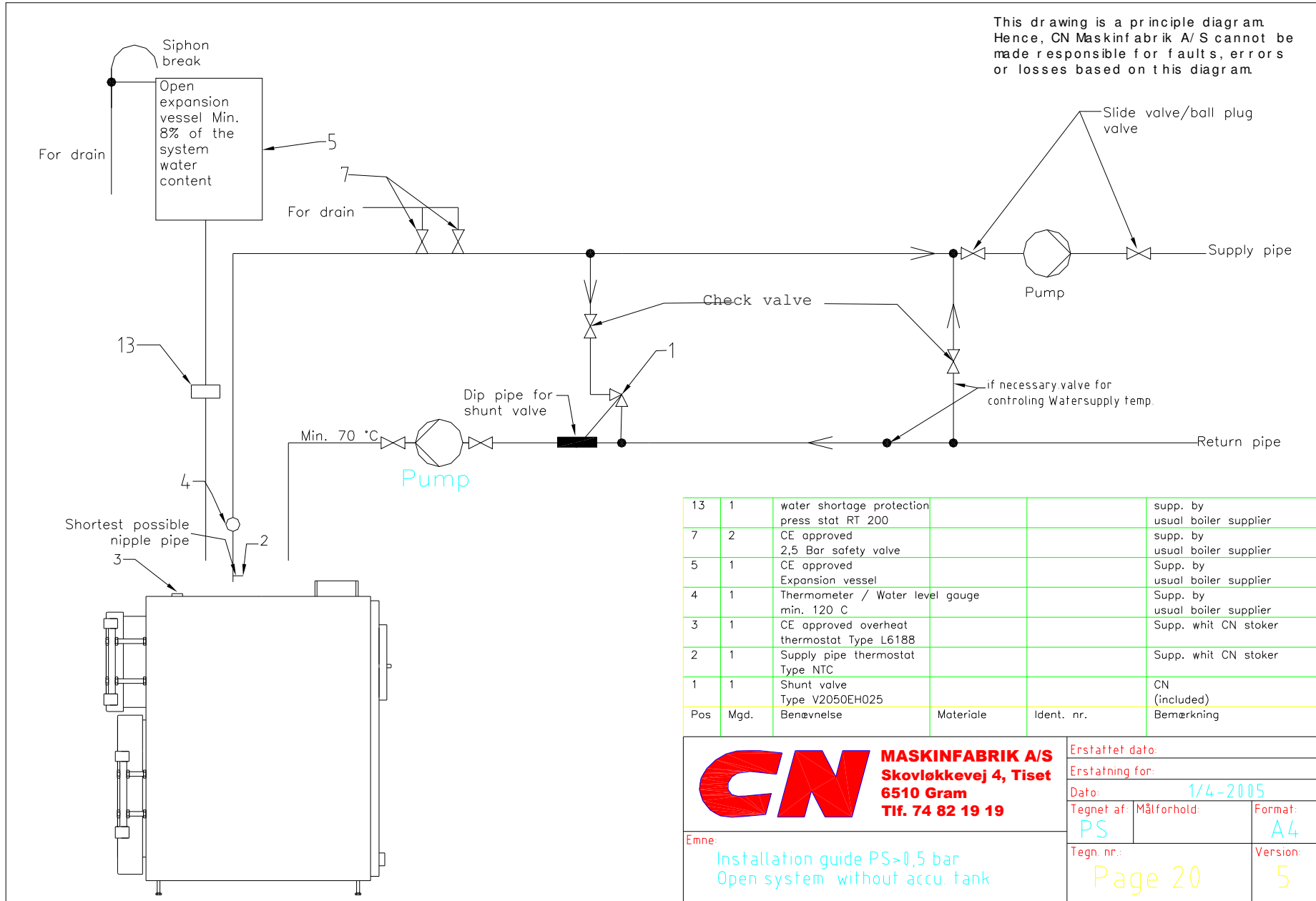

13	1	water shortage protection press stat RT 200			supp. by usual boiler supplier
7	2	CE approved 2,5 Bar safety valve			supp. by usual boiler supplier
5	1	CE approved Expansion vessel			Supp. by usual boiler supplier
4	1	Thermometer / Water level gauge min. 120 C			Supp. by usual boiler supplier
3	1	CE approved overheat thermostat Type L6188			Supp. whit CN stoker
2	1	Supply pipe thermostat Type NTC			Supp. whit CN stoker
1	1	Shunt valve Type V2050EH025			CN (included)
Pos	Mgd.	Benævneelse	Materiale	Ident. nr.	Bemærkning

CN MASKINFABRIK A/S
 Skovløkkevej 4, Tiset
 6510 Gram
 Tlf. 74 82 19 19

Erstattet dato:		
Erstatning for:		
Dato: 1/4-2005		
Tegnet af: PS	Målforhold:	Format: A4
Tegn. nr.:	Version: 5	

Emne: Installation guide PS > 0,5 bar
 Open system without accu. tank

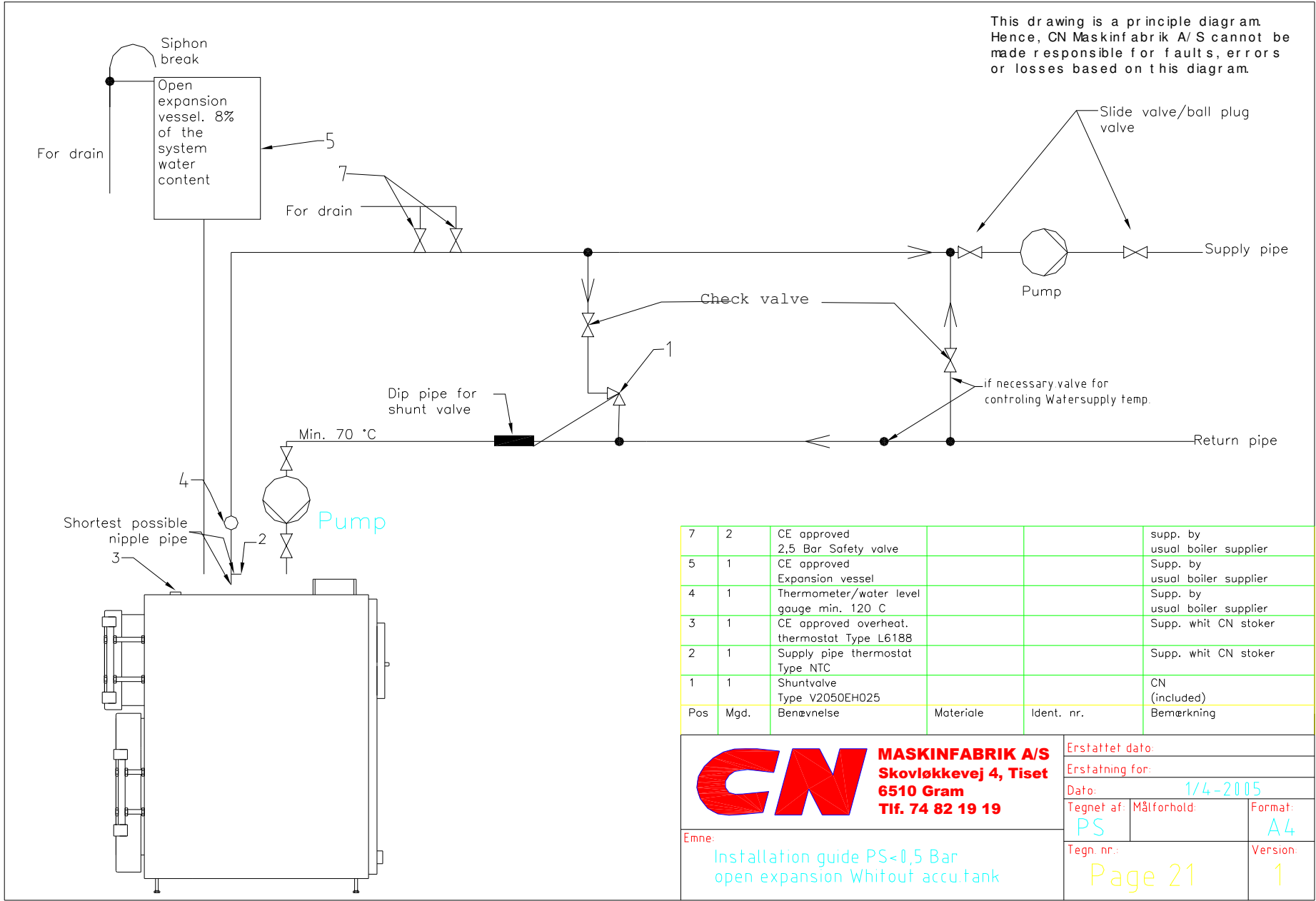

7	2	CE approved 2,5 Bar Safety valve			supp. by usual boiler supplier
5	1	CE approved Expansion vessel			Supp. by usual boiler supplier
4	1	Thermometer/water level gauge min. 120 C			Supp. by usual boiler supplier
3	1	CE approved overheat. thermostat Type L6188			Supp. whit CN stoker
2	1	Supply pipe thermostat Type NTC			Supp. whit CN stoker
1	1	Shuntvalve Type V2050EH025			CN (included)
Pos	Mgd.	Benævneelse	Materiale	Ident. nr.	Bemærkning

CN MASKINFABRIK A/S
 Skovløkkevej 4, Tiset
 6510 Gram
 Tlf. 74 82 19 19

Erstattet dato:
 Erstatning for:
 Dato: 1/4-2005
 Tegnet af: PS Målforhold: A4
 Tegn. nr.: Page 21 Version: 1

Emne: Installation guide PS<0,5 Bar open expansion Whitout accu.tank