

Planning Department  
North Lincolnshire Council  
Civic Centre  
Ashby Road  
Scunthorpe  
DN16 1AB

**Our ref:** AN/2013/116846/01-L01

**Your ref:** PA/2013/0297

**Date:** 04 April 2013

FAO Tanya Coggon

Dear Sir/Madam

**Planning permission to install two generators and a fuel tank  
Cadney Reservoir, Cadney**

Thank you for referring the above application, on 14 March 2013.

**Environment Agency position**

The proposed development will only meet the requirements of the National Planning Policy Framework if the following measures as detailed in the submitted Flood Risk Assessment are secured by way of a planning condition.

**Condition**

The development shall only be carried out in accordance with the approved Flood Risk Assessment (FRA) dated March 2013. Specifically, the finished floor level of the concrete slab shall be set no lower than 3.05 m above Ordnance Datum (AOD).

**Reason**

To reduce the risk of flooding to the proposed development and future occupants.

**Informative advice**

I attach a pollution prevention guidance note for above ground oil storage for the applicant's attention. This is also available on our website at:  
<http://www.environment-agency.gov.uk/business/topics/pollution/39083.aspx>

Should you require any additional information, or wish to discuss these matters further, please do not hesitate to contact me on the number below.

Yours faithfully

**Nicola Farr**  
**Planning Advisor**

Waterside House, Waterside North, Lincoln, LN2 5HA  
Customer services line: 03708 506 506  
Email: [PlannL.Lincoln2.AN@environment-agency.gov.uk](mailto:PlannL.Lincoln2.AN@environment-agency.gov.uk)  
[www.environment-agency.gov.uk](http://www.environment-agency.gov.uk)

Calls to 03 numbers cost no more than national rate calls to 01 or 02 numbers and count towards any inclusive minutes in the same way. This applies to calls from any type of line including mobile.

Direct dial 01522 785967 Direct fax 01522 785040  
Direct e-mail [nicola.farr@environment-agency.gov.uk](mailto:nicola.farr@environment-agency.gov.uk)

# Pollution Prevention Guidelines:

August 2011

## Safe storage

### Above ground oil storage tanks: PPG 2

These guidelines are produced by the Environment Agency for England and Wales, the Northern Ireland Environment Agency and the Scottish Environment Protection Agency, referred to here as 'we' or 'us'.

Pollution Prevention Guidelines (PPGs) are based on relevant legislation and reflect current good practice. Following the guidelines will help you manage your environmental responsibilities to prevent pollution and comply with the law.

If you cause pollution or allow it to occur, you may be committing a criminal offence.

You can find our contact details at the end of these guidelines.

This document is produced in accordance with the Code of Practice on Guidance on Regulation, reference 1.

## 1. Introduction

Following these guidelines will help you comply with the requirements of the Control of Pollution (Oil Storage) (England) Regulations 2001 (OSR England), the Control of Pollution (Oil Storage) Regulations (Northern Ireland) 2010 and the Water Environment (Oil Storage) (Scotland) Regulations 2006.

They will help you look after your above ground oil storage tanks safely and to minimise the risk of causing pollution. They're good practice advice for tank owners and users but may also be of use to others. We've tried to avoid too much technical information; if you need more detailed information, we have referenced where you can find this throughout the guidance.

The pollution prevention principles below apply to all above ground oil storage, but these guidelines are specifically written for domestic and small or medium sized commercial oil storage. We refer to legislation that you must follow.

The guidance covers:

- installation of new or replacement tanks
- compliance with legal requirements for existing tanks
- current good practice.

For information and guidance on other types of storage please see References 2 to 6 (Section 15):

- underground oil storage
- drums
- intermediate bulk containers
- large industrial oil tanks.
- tank farms
- forecourt oil storage
- storage for dispensing into vehicles

In the case of forecourt oil storage, only suitably-qualified competent contractors approved for working on hazardous sites should be used to install or perform maintenance on your oil tanks. Guidance for oil refineries and distribution depots is available from the Energy Institute, contact details in Section 15.

## 2. Key points

You need to consider the following points to make sure your above ground oil storage is safe, secure and legal. Each point has further detail in the listed sections.

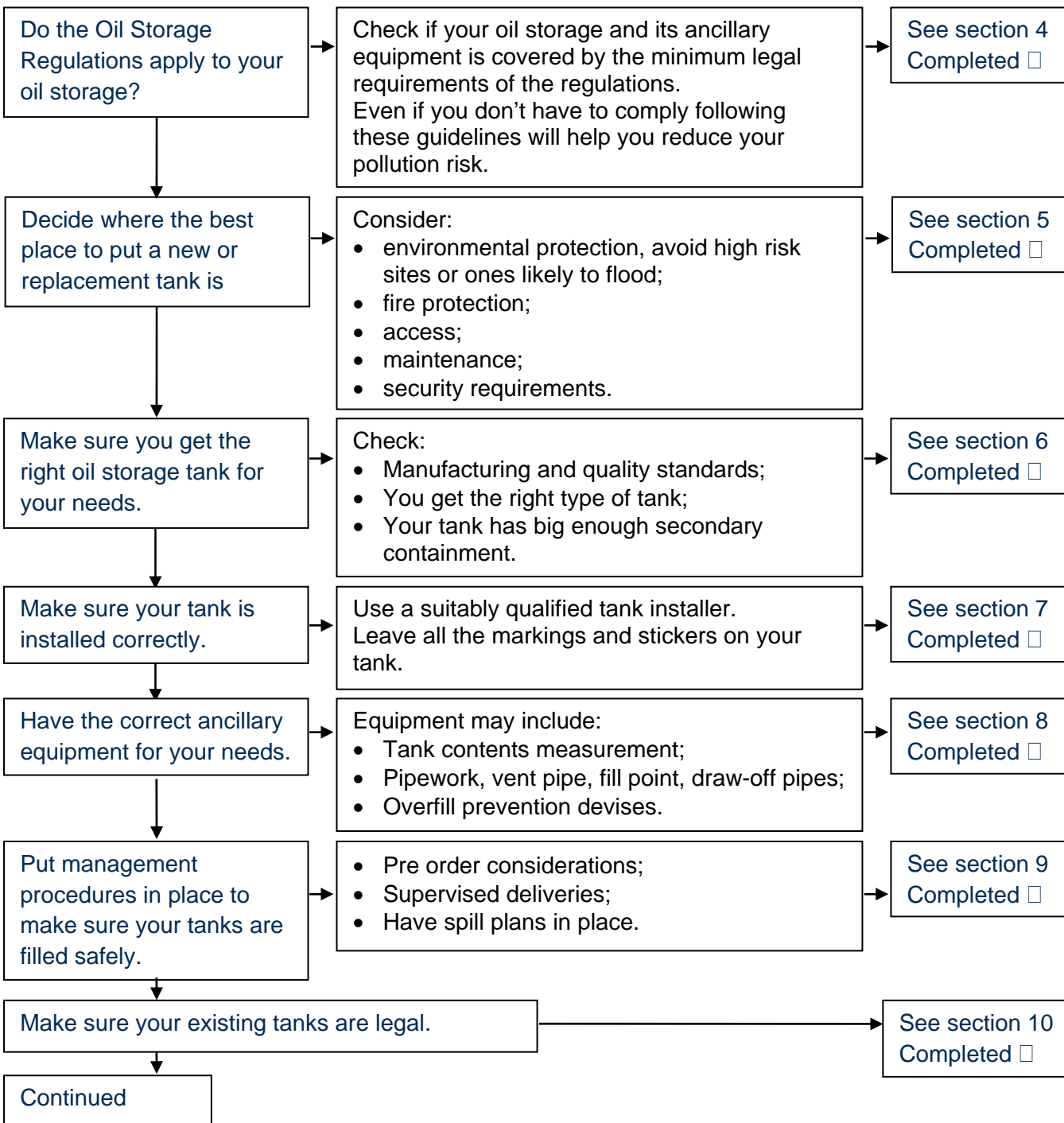

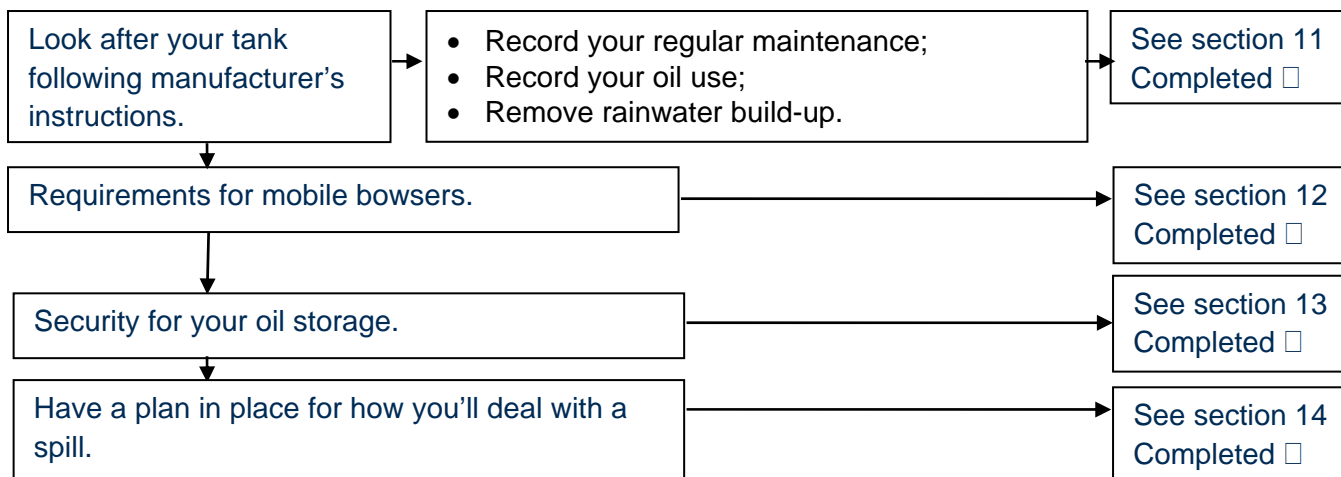

### 3. Background

Oil is among the most common pollutants in the UK. Cleaning up oil spills can be difficult and expensive. Dealing with a spill will cause you and maybe your neighbours a great deal of inconvenience. Make sure you have insurance cover, not just to replace the lost oil. Your policy should include:

- environmental clean up for accidental oil loss;
- a high enough liability limit to cover you if neighbouring land and/or boreholes are affected;
- the costs of cleaning up oil on your own property.

By following these guidelines you will reduce the risk of pollution caused by the poor storage of oil in above ground tank installations, poorly maintained tanks and unsuitable filling practices.

### 4. Legal background

In England and Wales, it is against the law to cause water pollution and there are specific regulations that may apply to your oil storage tank. Non compliance with these regulations is an offence and may result in enforcement action being taken against you.

In Northern Ireland, the Water (NI) Order 1999 means you need a consent for discharge from NIEA before you make any discharges into the water environment, surface water or groundwater. If you make a discharge without a consent, or that doesn't meet the conditions of your consent, you are committing an offence.

In Scotland, the storage of oil is regulated by the Water Environment (Oil Storage) (Scotland) Regulations 2006, (OSR Scotland), as detailed below. Where oil storage results in pollution of the water environment, this may constitute an offence under the Water Environment (Controlled Activities) (Scotland) Regulations 2005, as amended. Non compliance with these regulations may result in enforcement action being taken against you.

#### 4.a Control of Pollution (Oil Storage) Regulations

In England, above ground oil storage is regulated by the Control of Pollution (Oil Storage) (England) Regulations 2001, (OSR England). Oils covered by these regulations include petrol, diesel, vegetable, synthetic and mineral oils. They apply to most industrial, commercial and institutional sites storing oil

in containers over 200 litres and to private dwellings with containers storing more than 3,500 litres. The Environment Agency is responsible for enforcing these regulations throughout England and may serve an Anti Pollution Works Notice requiring inadequate facilities to be brought up to standard. Answers to a number of frequently asked questions are available on our web site at [www.environment-agency.gov.uk/osr](http://www.environment-agency.gov.uk/osr).

In Northern Ireland, oil storage is regulated by the Control of Pollution (Oil Storage) Regulations (Northern Ireland) 2010, (OSR NI). Under these Regulations 'oil' means any kind of oil and includes petrol, diesel, waste, vegetable and plant oils; but doesn't include uncut bitumen. The regulations apply to industrial, commercial, institutional and public body sites storing oil in containers over 200 litres, including drums and IBCs, and to domestic premises storing 3500 litres and over. They came into effect on 20 March 2011 and their implementation is being phased in. You should check with the NIEA to find when your oil storage must comply.

In Scotland, oil storage is regulated by the Water Environment (Oil Storage) (Scotland) Regulations 2006 (OSR Scotland). These regulations apply to any kind of oil including petrol, diesel, mineral oil, heating oil, lubricating oil, agricultural fuel oil, waste oil and vegetable and plant oils. They don't include uncut bitumen. They apply to the storage of any volume of oil, except private dwellings storing oil in a container with a capacity of 2,500 litres of oil or less. The Scottish Environment Protection Agency (SEPA) is responsible for enforcing these regulations throughout Scotland.

Throughout this guidance we've highlighted text indicating areas that must be complied with under the English, Northern Ireland and Scottish oil storage regulations. Where the regulations differ we've included information about the regulations for each country. Where the term 'must' is used, this refers to your legal requirement under these Regulations where they apply (see References 7 and 8 and the oil storage information pages in useful websites).

Where the Regulations apply.

In England:

- Above ground oil storage in containers over 200 litres.
- Private domestic oil tanks over 3,500 litres.

In Northern Ireland:

- Above ground oil storage in containers over 200 litres.
- Private domestic oil tanks over 3,500 litres.
- Waste oil storage.
- Oil stored in buildings - see Section 7.

In Scotland:

- All above ground oil storage (except domestic oil tanks of 2500 litres or less).
- Portable containers of less than 200 litres\*.
- Waste oil storage - see PPG8, Reference 9.
- Oil stored on farms - see Reference 10.
- Oil stored in buildings - see Section 7.

\*In Scotland any oil storage container must be strong enough not to leak in ordinary use. Portable containers with a storage capacity under 200 litres don't have to comply with the more prescriptive requirements of the OSR Scotland, such as secondary containment, which apply to the remainder of the list above.

Where the Regulations don't apply:

**In England:**

- Waste mineral oil storage - see Reference 9.
- Oil stored on farms for agricultural heat and power - see References 10 and 11.
- Oil stored in buildings. Follow good practice recommendations.
- Oil stored wholly underground.
- Premises used for refining oil.
- Premises used for the onward distribution of oil to other places.

**In Northern Ireland:**

- Oil stored on farms for agricultural use - see References 10 and 11.
- Oil stored on premises regulated under the Control of Major Accident Hazards Regulations (Northern Ireland) 2000 where the container is 2500 tonnes or more.
- Oil stored wholly underground.

**In Scotland:**

- Oil stored in accordance with PPC Part A permits.
- Oil distribution depots for onward distribution to other places.
- Oil stored wholly underground, unless it's in a building.
- Oil stored in vehicles.

**In Wales:**

- There aren't any equivalent oil storage regulations in Wales. You should follow the good practice advice in this PPG to reduce your risk of causing pollution.

The differences in implementation timescales between OSR England, OSR NI and OSR Scotland are:

**In England:**

- All non-exempt oil storage in England must comply with the Control of Pollution (Oil Storage) (England) Regulations 2001.

**In Northern Ireland – phased implementation:**

- New non-exempt tanks installed after 19 March 2011 must comply by 20 September 2011.
- Tanks installed before 19 March 2011 and within 10 metres of any waterway or 50 metres of any well, spring or borehole must comply by 20 March 2013.
- All other tanks installed before 19 March 2011 must comply by 31 December 2015.

**In Scotland:**

- All non-exempt oil storage in Scotland must comply with the Water Environment (Oil Storage) (Scotland) Regulations 2006.

Appendix A contains a checklist to help you decide whether improvements are needed to your oil storage system to comply with the OSR in England, Northern Ireland and Scotland. You must consider the timescales for the Regulations to decide when your oil storage must comply.

Similar regulations may follow in Wales. You can contact us for more advice.

## 4.b Building Regulations

Oil tanks connected to fixed combustion appliances, like central heating boilers and cookers, need to comply with the building regulations that apply in England, Northern Ireland, Scotland or Wales (Reference 12). These regulations include requirements for both environmental protection and fire safety. If you're having a new or replacement oil tank fitted or having your tank altered, you should check with your local authority (usually your local council) to see how these Regulations apply to your oil storage tank, or you can have the tank installed by a member of a professional scheme (see Section 15).

Even if your oil tank isn't covered by any of the Regulations above, following these guidelines is good practice and will minimise the risk of your oil causing pollution. In some sensitive locations, we may ask for more stringent environment protection measures than are described here.

## 4.c The Environmental Damage Regulations or Environmental Liability Regulations

Depending on where you are in the UK (see reference 13) these regulations require people who operate an 'economic' activity to prevent or limit the environmental damage they cause. This includes:

- private businesses
- farming
- manufacturing businesses
- construction and demolition businesses
- waste management businesses
- forestry operations
- public sector – schools, hospitals and government departments or agencies
- charitable and voluntary organisations.

These Regulations require polluters to prevent serious environmental damage from their activities or to take action to remedy it. Environmental damage includes:

- serious damage to surface water or groundwater;
- contamination of land where there is a significant risk to human health;
- serious damage to EU protected species or natural habitats, or damage to Sites of Special Scientific Interest (SSSIs) in England and Wales or Areas of Special Scientific Interest (ASSIs) in Northern Ireland.

They follow the 'polluter pays' principle. If there's a risk of damage from your business activities, you must do your best to prevent the damage occurring.

## 5. Deciding where to put your tank

You should think about environmental and fire protection, access, maintenance and security requirements before deciding where to put a new or replacement oil storage tank.

### 5.a Avoid high risk locations

We recommend that you don't store oil in high risk locations; these are:

- within 50 metres of a spring, well or borehole;
- within 10 metres of a watercourse;
- places where spilt oil could enter open drains, loose fitting manhole covers or soak into the ground where it could pollute groundwater;
- places where a spill could run over hard ground to enter a watercourse or soak into the ground where it could pollute groundwater;
- places where tank vent pipe outlets can't be seen from the filling point;
- above roof level as spilt oil can run down guttering which is connected to surface water systems.

Oil spilt in these locations will pollute surface waters and groundwaters. If these locations are unavoidable then check with us before you arrange for a new tank to be installed, as we may require additional environmental protection, e.g. overfill prevention device or oil separator on the surface water drainage system.

We recommend at all sites that you have secondary containment for your oil storage tanks wherever you put them, even if it's not required by OSR or Building Regulations, (see Section 6c).

You should or, if OSR applies must, ensure that steps are taken, **to minimise the risk of damage to the secondary containment system by impact** or collision.

You should consider access for maintenance and deliveries to the tank (filling). Check with your local oil delivery company before making the final decision on where to place a tank. They need to take into account pollution prevention and health and safety aspects of filling your tank. This includes where they can safely park the oil tanker, where the delivery pipes will run and access to the tank. They will also be able to give advice relating to height of the fill point above ground and delivery pipe sizing.

### 5.b Avoid storing oil in areas at risk from flooding

Containers may float in a flood which could cause pipelines to break and oil to be spilled. If there's no alternative, consider raising tanks above predicted flood water levels as long as this doesn't compromise the tank integrity, safe delivery and handling of your oil. You could also secure your tank so it can't lift as water rises around it. Contact a competent installer, (see Section 15) for advice on securing your tank. Contact us to check if your tank is in an area at risk from flooding. In England, Scotland and Wales you can check our websites for flood maps, which provide details of flood risk areas.

## 6. Oil storage tanks

Before choosing a new or replacement tank, you should check the following:

- if there are any legal requirements you must comply with;
- that it meets minimum manufacturing standards;
- the type of tank is suited to your requirements.

Also consider the:

- type of oil to be stored
- need for secondary containment
- location of the tank
- safe filling and dispensing.
- safe installation and routine maintenance
- intended use

If you're replacing a tank you'll also have to consider what to do with your old one.

### 6.a Manufacturing and Quality Standards

There are recognised British Standard and trade association tank standards for different types of tank. Your tank manufacturer, supplier or installer should advise you on the minimum design and manufacturing standards under the appropriate accredited quality assurance scheme. It should comply with BS EN ISO 9001 (Reference 14). Plastic and steel tanks and tank systems manufactured to OFTEC Standards, OFS T100 and OFS T200 respectively, meet these requirements.

Please note that compliance with standards for construction and manufacture doesn't guarantee compliance with OSR. Other aspects such as pipework, location and deliveries, also affect OSR compliance.

Choose a tank that:

- is expected to last at least 20 years, with proper maintenance, before it needs to be replaced;
- is made of a material that is suitable for the type of oil stored;
- is of sufficient strength and structural integrity to ensure that it won't burst or leak in ordinary use;
- has a way of preventing drain down by gravity e.g. top off-take and / or isolating check valves.

Check the recommended maintenance needed for your tank with the manufacturer.

### 6.b Types of oil storage tank

There are a number of different types of oil storage tanks available. Above ground oil tanks are usually made from steel or polyethylene (plastic). They can be single skinned, double skinned or have a built in bund (integrally bunded) as a complete containment system.

**Single skinned tanks** are tanks made from one layer of steel or plastic. **Single skinned tanks must be put into a secondary containment system**, often referred to as a bund.

**Double skinned tanks** have two layers of steel or plastic with a very small space between them; any ancillary equipment is positioned outside the second skin. The space between the two layers is not enough to contain 110% of the oil your tank can hold. If you choose a double skinned tank, it will not be compliant with the OSR England, OSR NI or OSR Scotland unless it's installed in a constructed secondary containment system.

**Integrally bundled tanks** have a primary container manufactured with integral secondary containment (see Section 6c and Figure 2) that can hold a minimum of 110% of the volume of oil the inner tank is designed for (Reference 15). Ancillary equipment will also be positioned within the secondary containment.

Figure 1. Shows a diagrammatic example of a single skinned oil tank in an open bund that is constructed in situ. The diagram shows both fixed and flexible draw-off pipes. For tanks in open bunds, we recommend there is a minimum distance of 750 mm between the tank and the bund wall and 600 mm between the tank and the base to allow access for external inspection and maintenance.

Figure 2. Shows a diagrammatic example of an integrally bundled oil tank. These tanks are manufactured off site and installed onto a suitably constructed base. The diagram shows a fixed draw-off pipe, overfill prevention device and oil monitoring between the tank and secondary containment.

Figure 1. Example of a single skinned oil tank within an open bund

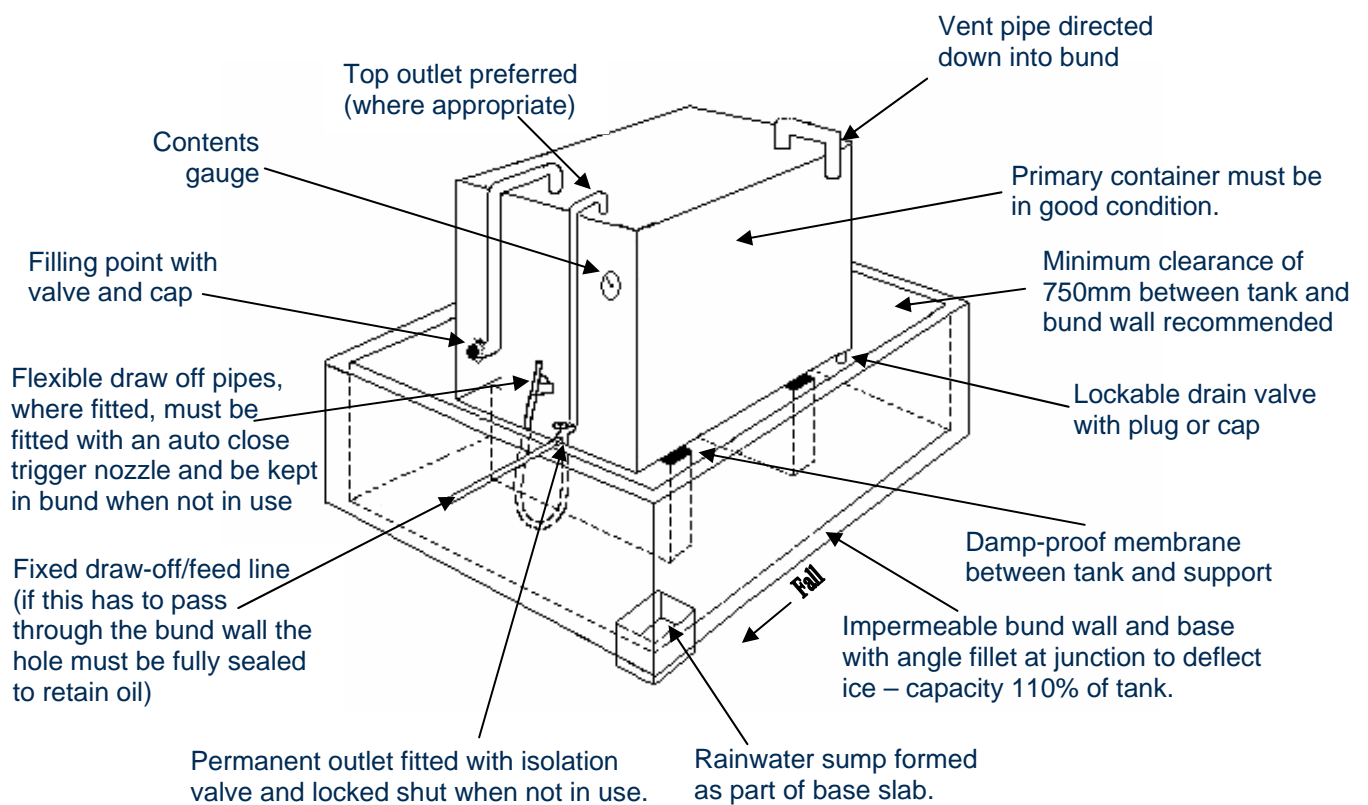
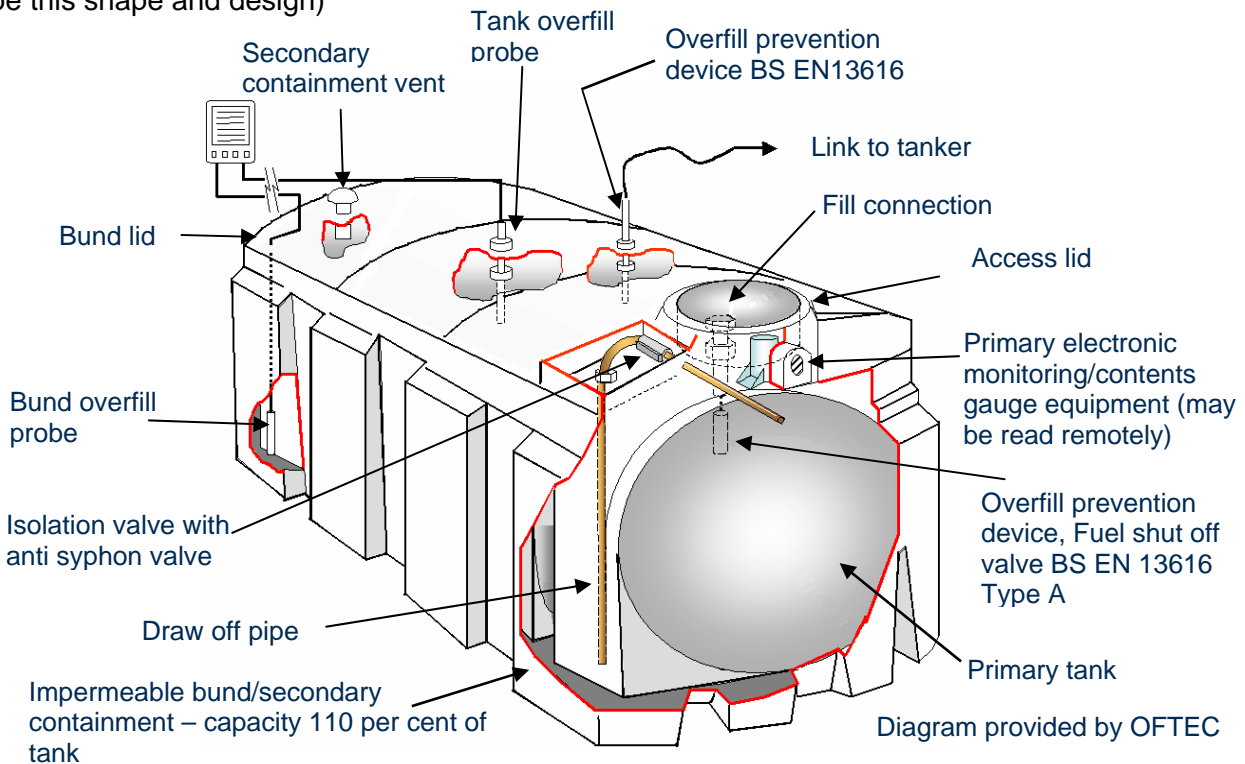

Figure 2. Example of integrally bundled tank (could be constructed of metal or polyethylene and may not be this shape and design)



Figures 1 and 2 aren't drawn to scale or engineering drawings. They are for illustration only. Different configurations exist depending on the manufacturer, type of tank and installation.

### 6.c Secondary Containment (also known as bunds)

Secondary containment is an area around a tank and its ancillary equipment designed to contain any loss of oil and to prevent it from escaping to the environment. It can be manufactured as part of an integrally bundled tank system or built on site ready for the tank to be put into it. Your tank may need to have secondary containment by law depending on where it is and what it's used for. But to protect the environment we recommend you should bund all tanks as it is good environmental practice.

**Secondary containment must hold at least 110% of the volume of oil the tank is designed to contain.**

The extra 10% margin is intended to take into account a range of factors, including:

- loss of the total tank contents, for example due to vandalism or an accident;
- sudden tank failure or leaks;
- overfilling;
- containment of fire-fighting agents;
- dynamic factors such as overtopping caused by surge and wave action following tank failure;
- an allowance for rainfall during an oil spill incident.

**If you have more than one oil storage tank in the system, the secondary containment must be capable of storing 110% of the biggest tank's capacity or 25% of the total capacity, whichever is the greater.**

**Secondary containment must be impermeable to oil and water with no direct outlet:**

- connecting it to any drain, sewer or watercourse;
- discharging onto a yard or unmade ground.

Ideally, any pipework to fill or empty your tank shouldn't pass through the secondary containment floor or walls (the bund). If this is unavoidable, **the joint between pipe and bund should be sealed with a material that is resistant to attack by the oil stored, so that the containment remains leak-proof.**

Don't store anything in the secondary containment as this will reduce the volume available in the event of a spill and can cause a fire risk if it becomes soaked in oil.

For agricultural oil storage in England, Northern Ireland and Wales it is a legal requirement that bunds are expected to remain impermeable, with proper maintenance, for at least 20 years, (see References 10 and 11).

If you're considering an integrally bunded tank system, check with the manufacturer to make sure that it is designed to provide at least 110% secondary containment capacity. Some tank systems may not provide enough capacity if your tank is overfilled. Be aware that it isn't easy to see into the secondary containment section of an integrally bunded tank. We recommend your tank is fitted with an overflow prevention device and secondary containment sensors that detect if oil has collected in the bund from an incorrect delivery, overflow or inner tank problem and to warn you if additional maintenance is needed.

## **7. Installing tanks**

You should have your tank installed by a suitably-qualified tank installer who's registered with a professional scheme for the type of tank you're having installed. They will make sure that tanks are installed according to the relevant standards and good practice. Professional schemes are run by a number of organisations (see Section 15 for more details).

Tanks should be sited on an appropriately designed and constructed base or support with sufficient room around it to protect the tank from fire in the surrounding area, see BS 5410 (Reference 16). Check what you need for your tank with the tank manufacturer or competent installer.

To prevent pollution, the delivery and dispensing area around your tank should have an impermeable surface and be isolated from surface water drainage systems.

Make sure you keep the manufacturers and installers information for your tank. Leave all the markings and stickers on your tank when it's installed. These include tank manufacturer, make, model and capacity markings. Many oil tanks come supplied with an Oil Care Campaign tank sticker that gives information about what to do if you have an oil spill. It may be a legal requirement for your tank to have this. If your tank doesn't have an Oil Care Campaign tank sticker, you can get one from us. If you have more than one tank, label all your tanks and their fill points clearly, with the type of product stored and tank capacity.

You should protect your oil storage tank from the risk of fire. Building Regulations (Reference 12) allow for fire protection by using approved distance between the tank and surrounding structures or by a physical fire protection barrier. Don't store any materials close to your tank or in the secondary containment.

**Tanks within buildings** – in Northern Ireland and Scotland these must comply with OSRNI or OSR Scotland. In England and Wales follow all good practice recommendations to prevent pollution. Building Regulations are likely to apply.

### **For tanks in constructed secondary containment**

If your tank is being installed in a constructed bund, the bund should be built using reinforced materials, with no damp-proof course and rendered impermeable to oil. There are detailed specifications and drawings available for constructed bunds using concrete and masonry (References 17, 18 and 19). These will make sure your masonry or concrete bunds are constructed to be oil tight and fit for purpose.

Your bund should be designed to reduce the risk of oil escaping beyond the containment area if your tank developed a hole (known as jetting).

To reduce the chance of this happening:

- keep the tank as low as possible within the bund;
- increase the height of the bund walls;
- leave space between the tank and bund walls;
- don't put one tank above another.

A constructed bund should also have a sump fitted into the base so you can remove rainwater for safe and legal disposal, (see Figure 1).

The Construction Industry Research and Information Association (CIRIA) suggests in locations with high rainfall, 110% capacity in an open bund may not be enough to provide protection from loss of oil (see Reference 17). They give an alternative method to calculate the size of secondary containment needed for tanks in open bunds in locations with high rainfall. The method for calculating bund capacity depends on the risk of polluting water. If you're in any doubt about the sensitivity of a site, consult us.

## **8. Ancillary equipment**

These are the fittings and pipework that all tanks will have, e.g. a vent pipe, but others may be needed according to the tank type, location or use.

For example:

- a heating oil tank may have a fixed draw off pipe;
- a tank used for refuelling may have a pump and flexible hose to deliver oil;
- a tank with a remote fill point or in a sensitive location may have an overflow prevention device.

**Ancillary equipment, e.g. valves, filters, sight gauges, vent pipes, must be within the secondary containment system so any discharges of oil are retained.**

Many of these fittings are shown in Figures 1 and 2 above and are discussed below.

An oil tank user guide 'Get to know your oil tank', might also be useful to you, Reference 20.

## 8.a Measuring tank contents

You need to be able to measure how much oil is left in your tank so you can order the right amount when your tank needs refilling and to monitor how fast you use your oil. There are many products available to measure tank contents including electronic, float and hydrostatic gauges, sight or visual gauges and dip sticks. Some are read at the tank others remotely. Ask the tank manufacturer or a qualified competent tank installer for advice on a suitable system for your tank. If storing flammable liquids (as classed by Health and Safety Executive (HSE)), your gauge should be safe for use with the product you store.

### Sight gauges

- must be located in the secondary containment;
- must be properly supported so it can't come loose;
- must be fitted with a valve that closes automatically when the gauge isn't in use;
- valves should never be kept open;
- valves should only be opened when taking contents' readings.

Delivery drivers should close sight gauge valves at the end of their delivery. After your tank has been filled, check that the sight gauge is shut and isn't leaking. Sight gauge tubes aren't suitable for use with integrally banded oil tanks.

Dipstick - only use it in the tank for which it is intended.

## 8.b Pipework

### All pipework should be:

- made of a material suitable for use with the oil you're storing;
- supported so it's secure and can't come loose;
- positioned or protected to minimise the chances of damage by impact or collision;
- protected against corrosion;
- where appropriate, insulated to prevent freezing up and frost damage.

### Vent pipe

This allows oil vapour and air to escape from the tank when it is being filled and allows air in when fuel is being drawn off.

We recommend that tanks (including those in buildings) are installed so that vent pipes can be easily seen during deliveries; and that the vent pipes are within and discharge into the secondary containment system.

Legal requirements:

In England:

- Vent pipes must be within the secondary containment system and must be arranged so that any discharge is directed vertically downwards into the system.
- The tank must be fitted with an automatic overfill protection device, if the filling operation is controlled from a place where it is not reasonably practicable to see the tank and any vent pipe.

In Northern Ireland:

- Vent pipes must be within the secondary containment system and must be arranged so any oil discharged is contained within the system.
- The tank must be fitted with an automatic overfill protection device (which may include an alarm sounding device) if the filling operation is controlled from a place where it is not reasonably practical to observe the tank or any vent pipe.

In Scotland:

- Vent pipes (including those on tanks within buildings) must be within the secondary containment system.
- The tank must be fitted with an automatic overfill protection device (which may include an alarm sounding device) if the filling operation is controlled from a place where it is not reasonably practical to observe the tank or any vent pipe.

### Fill point

The fill point is where the tanker delivery pipework connects to fill the tank. There are different arrangements depending on tank type, size and location.

Coupling - If your tank fill point has a serviceable screw fitting or other fixed coupling, it must be used when filling the tank. The fill point should have a lockable fill cap with a chain and be marked clearly with the product type, tank capacity and, where appropriate, tank number. The cap should be replaced to the pipe after each delivery to protect it from damage and unauthorised use.

Position – we recommend your fill point should be at the tank and within the secondary containment system (OSR England only) or in a suitable cabinet with a drip tray to catch any oil spilled during deliveries. Where your fill point is outside the secondary containment system, a drip tray must be used to catch any oil spilled during deliveries.

Fill point drip trays should be:

- clean, free from water and other debris before each use;
- large enough to hold all the oil that could be lost when the fill point shut off valve has been closed and the delivery hose is disconnected;
- able to be moved without risk of spilling the oil - we recommend your drip tray holds at least 3 litres, it may need to be larger;
- checked after each delivery and if necessary safely emptied before being put away; we recommend you ask your oil delivery company to do this for you;
- kept somewhere safe where they can't collect rain water when not in use.

Remote fill - if there's no alternative and you have to have a fill point which isn't near the tank (or it isn't practical to see the tank and vent pipe), a remote fill point will be needed. Your registered, competent tank installer (see Section 15) can advise you about standards required for remote fill points. If you have a remote filling point and the vent pipe can't be seen during delivery you must have an overfill prevention device.

Shut-off valves should be fitted to extended fill pipes because they can retain oil after the delivery.

**If you have more than one tank** - provide separate fill pipes for each tank, unless they're connected by a balance pipe with a greater flow capacity than the fill pipe. Each fill pipe should have its own fill point shut off valve, and be marked with its corresponding tank/compartments number, volume and type of oil.

### Pipework to take oil from your tank (draw-off or supply pipe)

The general points above apply. Whenever possible, site supply pipework above ground to make it easier to inspect and repair. We recommend using tanks that have top outlet off take pipes; and that feed lines should have anti siphon and isolating valves to prevent the tank contents draining down because of leaks, damage, theft or vandalism.

Use pumped dispensing from oil storage tanks for refuelling to reduce the chance of oil spills. If you can't avoid gravity dispensing then tanks should be properly supported and installed. Suitable secondary containment for the tank and its ancillary equipment should be designed to reduce the chance of oil 'jetting' from the high tank in the event of an overflow or damage.

Consider the risk to the user from working at height (to fill, inspect, maintain and draw-off), suitable ladders, railings and other health and safety equipment may be necessary.

**Filters or isolating valves** used to protect the draw-off pipe or downstream equipment in a gravity-feed system aren't considered ancillary to the container. Where practicable, locate this equipment within the secondary containment system. We recommend that valves should be lockable or have removable hand wheels.

### Flexible delivery pipes

These should only be used where you need to move the end delivery point, for example when fuelling vehicles. **Fit the pipe with a tap or valve at the delivery end, which closes automatically when not in use;** we recommend you use a trigger nozzle designed to dispense oil. **Where the pipe isn't fitted with an automatic shut-off device, it mustn't be possible to fix the tap or valve in the open position. The pipe must either:**

- **have a lockable valve where it leaves the tank which is locked when not in use and be kept in the secondary containment; or**
- **must be in an enclosed secure cabinet which is locked shut when not in use and has a drip tray.**

**Dispensing pumps** should be:

- **positioned to minimise the risk of damage by collision;**
- **fitted with a valve in its feed line that prevents the tank contents emptying if there's damage to the pump or feed line;**
- **protected from unauthorised use.**

Pumps **are not** ancillary to the oil tank. You should ensure any oil that could leak from a pump is contained either by a bund or drip tray. Pumps for oil with a flash point below 55°C should never be within the secondary containment system because of the risk of explosion. If your pump is within the secondary containment, check it's positioned above the 110% containment level so it can't become submerged.

## Underground pipework

These should be avoided where possible as they can't easily be checked for damage or leaks and have a greater risk of causing pollution. You should only use underground pipe work where you can't fit pipes above ground. If you do have them we recommend they should:

- be double skinned pipes
- be within concrete ducting
- have as few joints as possible
- be marked clearly on site plans and when possible on the ground.

Underground pipework must also be protected against corrosion and from physical damage like that caused by excessive surface loading, ground movement or ground disturbance. If mechanical joints have to be used, they must be readily accessible for inspection under a hatch or cover.

You must have adequate facilities for detecting leaks from underground pipework. If you use a continuous leak detection device, it should be maintained and tested regularly (in Scotland at least every 5 years). Keep a record of the test results and any maintenance work completed.

If you don't have a continuous leak detection system you must test:

- pipework before use
- pipework with mechanical joints every five years
- all other pipe work at least every ten years.

These are minimum requirements and it's good practice to do this more frequently.

## Taps and valves

Taps and valves that are permanently attached to the tank and that oil can be discharged from the tank through must:

- be fitted with a lock
- be locked shut when not in use.

## 8.c Overfill prevention devices

We recommend the use of overfill prevention devices to safeguard against spills. These can be electronic or mechanical which either sound an alarm and/or give a visual warning or automatically stop the oil delivery into the tank. They may be a legal requirement depending on tank location, fill point and vent pipe arrangements.

## 9. Safe deliveries to your tank

All your tanks should be labelled with the capacity and type of oil they contain and should be individually numbered to help identify them.

Before you order an oil delivery:

- check how much oil is in the tank
- work out the spare capacity
- decide how much oil you need but make sure you don't over order.

Supervise all deliveries. Ensure that whoever is supervising the delivery knows about the tank, its equipment and what to do if there's a spill. If you have more than one tank, make sure the correct tank

is being filled. The Federation of Petroleum Suppliers (FPS) produces information on safe deliveries. For additional information, see Section 15.

If your tank is filled from a place where it is not practicable to see the tank and any vent pipe, it may need to have a remote fill point fitted. **Where a tank has a remote filling point and the vent pipe can't be seen during the filling operation you must have an automatic overfill prevention device fitted to your tank.** We don't recommend remote filling points unless there isn't an alternative. Your registered, competent tank installer, (see Section 15) can advise you about standards required for remote fill points.

**If your tank has a serviceable screw fitting or other fixed coupling, it must be used when filling the tank.** Your fill point should have a lockable fill cap with a chain and be marked clearly with the product type, tank capacity and, where appropriate, tank number. Make sure the cap is replaced to the pipe after each delivery to protect it from damage and unauthorised use, (see Section 7b for more information on fill points).

### Dealing with spills

The area around your tank where deliveries are made and, if applicable, oil is dispensed should have an impermeable surface and be isolated from surface water drainage systems. This will prevent oil and/or contaminated water getting into the soil and groundwater. If any oil is spilt during an oil delivery, you should make sure that it can't run into a surface water drainage system.

You should consider if you need a suitably sized oil separator to direct oily liquid away from surface waters and prevent oil escaping from your site. This will reduce the risk of any spilt oil causing pollution if there's a spill. Also check with us to see if environmental sensitivities in your local area mean drainage from this area should pass through an oil separator of an approved design (see PPG 3: Reference 21).

## 10. Check legal compliance for your existing tanks

There may be legal requirements that your existing tank (including home heating tanks) need to comply with for the OSR England, OSR Scotland or Building Regulations. The checklist in Appendix A will help you check your tank for most OSR England and OSR Scotland requirements.

### 10.a Secondary containment capacity

**Make sure your secondary containment has the capacity to take at least 110% of the volume your oil tank can hold.**

**For integrally banded tanks**, you can contact the tank manufacturer with the model of your tank; this information should be on your tank somewhere. They should be able to confirm the secondary containment capacity.

**For single or double skinned tanks** within a constructed secondary containment system, you can calculate the bund volume yourself. You can take account of any volume taken up by tank supports within the bund and consider the volume taken up by any of the primary tank, pipework or pumps. Advice on calculating bund capacity is given in Appendix B.

## 11. Looking after your tank

The oil tank user guide 'Get to know your oil tank', Reference 20, contains simplified guidance on looking after your tank. Make sure you have a copy as it includes space for you to record essential information about your tank including when it's last annual check was.

### Maintenance

Your tank manufacturer will be able to tell you what regular maintenance your tank needs. Use a registered competent technician to check your tanks, secondary containment and pipework every year and remove any condensation water that has accumulated within the tank. You should receive a written report on the state of your tank after the inspection is completed. Any repairs or alterations detailed in the report should be done by a registered, competent technician straightaway.

You should also inspect all accessible parts of your tank, secondary containment, ancillary equipment and pipework regularly, for signs of damage or leaks. If you're unsure how frequently you should do this, contact us for advice. If you notice any damage, you should have it repaired or replaced immediately.

To make sure a constructed bund retains its integrity, use a reputable company to repair any defects in the bund wall or lining promptly.

**Keep a log** of the inspections, any repair work on your tanks and who's done it.

**Record oil usage.** Regularly make a note of how much oil is in your tank and compare this to your previous usage. Contact us if you need advice about methods of monitoring your oil use and how often. If you're suddenly using more oil and you can't explain why, this could indicate a problem with your tank or pipework. You should ask a registered, competent technician to check your tank and pipework for faults and make any repairs immediately.

**Removing rain water.** If you have a tank in an open bund, check the bund after heavy rainfall. If there's no rainwater in the bund, it might not be sealed properly and you should have it inspected and repaired. If rain water has collected in your bund, it will reduce the amount of oil it can contain. If it's necessary to remove accumulated rainwater, we recommend you do this with a manually operated pump or by bailing from the sump. Advice on disposal of bund water from domestic oil storage is available, (see Reference 22). In remote locations, you could use automatic systems that can distinguish between the oil and water in the bund. If you install one of these systems, you need to contact us for advice on where you can dispose of the discharge.

In the long term, it may be more cost-effective to construct a roof over the tank and secondary containment.

Water taken out of the bund might be contaminated. Any accumulated water, oil or debris should be removed and disposed of in line with waste management legislation. In all cases where wastes are removed, as the waste producer you are obliged under the Duty of Care (see Reference 23) to describe the waste accurately and dispose of it properly.

In England and Wales, waste contaminated with oil is classed as hazardous waste unless you can show there is under 0.1% oil.

In Northern Ireland, waste contaminated with oil is classed as hazardous waste, unless you can show there is under 0.1% oil.

In Scotland, waste contaminated with oil is classed as special waste, unless you can show there is under 0.1% oil. To establish if enough oil is present to make a waste special, a generic threshold of 0.1% may be used; however, if the result is below this, there may still be other hazards that make the waste special, such as flammability or toxicity, or the presence of other contaminants; for further information, see Reference 24.

A consignment note system applies for disposal of these hazardous or special wastes. For more details about waste oils, see either PPG8 (Reference 9) or our websites.

Don't use bunds as a store for materials or wastes as this will reduce their capacity and create a fire hazard.

### What you should do with your old tank

Make sure that a tank is fully drained, degassed and certified when it's taken out of use and before it's removed. Only suitably qualified and competent technicians should do this work. Never carry out work that heats the tank until after it has been degassed and the appropriate certificate issued (see Reference 25). Under waste management legislation, decommissioned tanks taken off site must be removed by a licensed waste carrier and must be accompanied by a waste transfer note. Tanks can only be disposed of at an appropriately licensed facility. Contact us to find your nearest site.

After your tank has been decommissioned or removed, check that the surrounding soil or groundwater hasn't been contaminated. This can include testing surface and subsurface soil and groundwater samples for products relating to what you were storing. If contamination is found, take action as soon as possible to remove the pollution. Make sure you repeat the testing after the work has been done to ensure all the contamination has been removed. For more information see Reference 2 or contact us.

## 12. Mobile bowzers

Mobile bowzers are oil storage containers that can dispense oil and are designed to be moved, either being towed or lifted onto another vehicle, but which can't move under their own power. As well as the requirements for the storage container (Section 5) and secondary containment (Section 6c) above, the following apply to mobile bowzers:

- Any flexible pipe, tap or valve must be fitted with a lock where it leaves the container and be locked shut when not in use;
- Flexible delivery pipes must be fitted with manually operated pumps or a valve at the delivery end that closes automatically when not in use. We recommend you use a nozzle designed to dispense oil;
- The pump or valve must have a lock and be locked shut when not in use.

More detailed information is also available in References 7 and 8.

## 13. Security

Your oil storage areas should be secured to prevent theft and vandalism. Permanent taps or valves through which oil can be discharged to open areas should be locked when not in use. Display a notice telling users to keep valves, nozzles and trigger guns locked when they're not in use. Pumps should also be protected from unauthorised use.

Valve taps or levers should be corrosion resistant, strong enough to be tamperproof when locked and marked to show whether they are open or closed. **When not in use, they should be locked shut.** If the tank is being decommissioned then any valve taps or levers should be fitted with a blanking cap or plug.

## 14. Oil spills

An oil spill from your tank is likely to cause pollution; this will damage the environment and your reputation. Keep a spill kit with commercial sorbent products, sand or earth close to your oil storage to deal with spills, and make sure you or your staff know how to use it safely. Our incident response planning guidance PPG21, Reference 25, tells you how to draw up a plan. Dealing with spills: PPG 22, reference 26, will help you decide what action you may be able to take if you have a spill. These guidelines set out best practice for producing an incident response plan to deal with an environmental incident on your site. Following a plan will help prevent or reduce environmental damage if an incident occurs.

If you have a spill, take immediate action to stop the oil getting into any drains or watercourses. If you can, soak up the spilt oil with the contents of your spill kit, without putting yourself in danger. Don't hose the spillage down or use any detergents to try to get rid of it; you could make the pollution worse. Notify us by calling the Emergency Hotline on 0800 80 70 60. If oil soaks into the ground, the soil soaked in oil should be removed, by a professional company, so it doesn't cause long term pollution. Store any materials that are soaked in oil in containers that won't let the oil run away until it can be correctly and legally disposed of. Surface and subsurface soil and groundwater samples may need to be taken and tested for products relating to the incident. For details on how to legally dispose of materials soaked in oil, see Reference 9.

## 15. References

All the Pollution Prevention Guidance notes (PPGs) are available at:

[www.environment-agency.gov.uk/ppg](http://www.environment-agency.gov.uk/ppg)

<http://www.doeni.gov.uk/niea/index/publications.htm?act=l&typ=s&ftx=ppg>

[www.sepa.org.uk/about\\_us/publications/guidance/ppgs.aspx](http://www.sepa.org.uk/about_us/publications/guidance/ppgs.aspx)

1. [Code of Practice on Guidance on Regulation 2009](#).
2. Installation, decommissioning and removal of underground storage tanks: PPG 27
3. Drums and intermediate bulk containers: PPG 26
4. Refuelling facilities: PPG 7
5. [Containment of bulk hazardous liquids at COMAH establishments Containment policy](#)
6. [Buncefield task group final report](#)
7. For England, [Keep your oil safe: The Control of Pollution \(Oil Storage\) \(England\) Regulations 2001](#) leaflet. Environment Agency.  
For Northern Ireland contact the NIEA for up to date information.  
For Scotland, Leaflet on Scottish Oil Storage Regulations - [Updated advice on storing oil in Scotland](#). SEPA

8. For England, [Guidance note for the Control of Pollution \(Oil Storage\) \(England\) Regulations 2001](#). Department for Environment, Food and Rural Affairs (Defra)  
For Northern Ireland, [Guidance note for the Control of Pollution \(oil storage\) Regulations \(Northern Ireland\) 2010](#). Department of the Environment  
For Scotland, [Guidance note for the Water Environment \(Oil Storage\) \(Scotland\) Regulations 2006](#). Scottish Government
9. Safe storage and disposal of used oils: PPG 8
10. In England and Wales, [Code of good agricultural practice, Protecting our water, soil and air](#). Defra  
In Northern Ireland, [Code of good agricultural practice for the prevention of pollution of water, air and soil](#), Department of Agriculture and Rural Development for Northern Ireland (DARD).  
In Scotland, [Prevention of Environmental Pollution from Agricultural Activity](#) (code of good practice) (PEPFAA Code) Scottish Government.
11. For England: [Guidance note for the Water Resources \(Control of Pollution\) \(Silage, Slurry and Agricultural Fuel Oil\) \(England\) Regulations 2010](#) (SSAFO)  
For Northern Ireland: [Guidance note for the Control of Pollution \(Silage, Slurry and Agricultural Fuel Oil\) Regulations \(Northern Ireland\) 2003](#)  
For Wales: [Guidance note for the Water Resources \(Control of Pollution\) \(Silage, Slurry and Agricultural Fuel Oil\) \(Wales\) Regulations 2010](#) (SSAFO)
12. In England and Wales, [The Building Regulations 2000. Combustion appliances and fuel storage systems Approved Document J](#)  
In Northern Ireland, [The Building \(Amendment\) Regulations \(Northern Ireland\) 2006 Technical booklet L](#)  
In Scotland, [Building \(Scotland\) Act 2003](#) and applicable regulations under that act; [Section 3 \(Environment\) of the Building Standards Technical Handbooks](#) (Domestic and Non Domestic Handbooks 2011), Scottish Government, particularly subsections 3.23 and 3.24 of both handbooks.
13. For England, [The Environmental Damage \(Prevention and Remediation\) Regulations 2009](#): Statutory Instrument 2009 No. 153  
For Northern Ireland, [The Environmental Liability \(Prevention and Remediation\) Regulations \(Northern Ireland\) 2009](#): Statutory Rules of Northern Ireland 2009 No. 252  
For Scotland, [The Environmental Liability \(Scotland\) Regulations 2009](#): Scottish Statutory Instrument 2009 No. 266, and amendment.  
For Wales, [The Environmental Damage \(Prevention and Remediation\) \(Wales\) Regulations 2009](#): Statutory Instrument 2009 No. 995 (W.81)
14. BS EN ISO 9001. Quality management systems Requirements. British Standards Institution BSI
15. [Above-ground proprietary prefabricated oil storage tank systems](#). C535. Construction Industry Research and Information Association (CIRIA)

16. BS 5410 -1:1997 Code of practice for oil firing. Installations up to 45 kW output capacity for space heating and hot water supply purposes. BSI  
BS 5410 -2: 1978 Code of practice for oil firing. Installations of 44kW and above output capacity for space heating, hot water and steam supply purposes. BSI  
BS 5410 -3: Code of practice for oil firing. Installations for furnaces, kilns, ovens and other industrial purposes. BSI
17. Construction of bunds for oil storage tanks. R 163. ISBN 0-8601-7468-9. CIRIA
18. [Concrete bunds for oil storage tanks](#). Agencies/CIRIA
19. [Masonry bunds for oil storage tanks](#). Agencies/CIRIA
20. [Get to know your oil tank](#). Oil Care Campaign
21. The use and design of oil separators in surface water drainage systems: PPG 3
22. [Guidance on the disposal of condensate and bund water](#). Joint OFTEC/WaterUK/ Environment Agency/SEPA publication.
23. Waste management, the Duty of Care, a code of practice (revised 1996), ISBN 0-11-753210X. The Stationery Office.
24. [Special Waste Advisory Note 04 - Oil Contaminated Wastes](#). SEPA
25. Cleaning and gas freeing of tanks containing flammable residues. Guidance note CS15. ISBN 0-7176-2166-9. Health and Safety Executive (HSE)
26. Incident response planning: PPG 21
27. Dealing with spills: PPG 22

#### **Other useful sources of information:**

Contact the Oil Bank Line at [www.oilbankline.org.uk](http://www.oilbankline.org.uk) or on 08708 506 506 for details of your nearest oil recycling bank.

Energy Institute. Tel: 020 7467 7100 [www.energyinst.org.uk/home](http://www.energyinst.org.uk/home)

- Design, Construction, Modification, maintenance and Decommissioning of filling Stations ISBN 0-85293-419X.

Federation of Petroleum Suppliers (FPS) Briefing Notes. [www.fpsonline.co.uk](http://www.fpsonline.co.uk)

- Making an oil delivery through a property.
- Information your oil distributor will need to know when you place an order.

## Useful websites:

The British Standards Institute <http://shop.bsigroup.com/>

The Construction Industry Research and Information Association (CIRIA) [www.ciria.org](http://www.ciria.org)

The Construction Licensing Executive (CLE) (Scotland) [www.clescotland.co.uk](http://www.clescotland.co.uk)

The government on-line business advice and support service:

- For England – Business Link [www.businesslink.gov.uk](http://www.businesslink.gov.uk)
- For Northern Ireland – NIBusinessInfo [www.nibusinessinfo.co.uk](http://www.nibusinessinfo.co.uk)
- For Scotland - Business Gateway [www.bgateway.com](http://www.bgateway.com)
- For Wales - Business Wales [www.business.wales.gov.uk](http://www.business.wales.gov.uk)
- NetRegs – [www.NetRegs.gov.uk](http://www.NetRegs.gov.uk)

Health and Safety Executive: [www.hse.gov.uk](http://www.hse.gov.uk)

The Oil Care Campaign:

- [Publications](#), for example leaflets and tank stickers, are available from, search for Oil Care
- For details of [oil recycling facilities](#) across the UK
- In Northern Ireland: [Oil Care Campaign](#)
- In Scotland: [Oil Care campaign](#)

Oil Storage information:

- For England – [www.environment-agency.gov.uk/osr](http://www.environment-agency.gov.uk/osr)
- For Northern Ireland - <http://www.doeni.gov.uk/niea/water-home/waterpollution.htm>
- For Scotland – [www.sepa.org.uk/water/water\\_regulation/regimes/pollution\\_control/oil\\_storage.aspx](http://www.sepa.org.uk/water/water_regulation/regimes/pollution_control/oil_storage.aspx)

Professional schemes for qualified tank installers:

- APHC - Association of Plumbing and Heating Contractors, England and Wales. [www.competentpersonsscheme.co.uk](http://www.competentpersonsscheme.co.uk)
- BESCA - Building Engineering Services Competence Accreditation Limited, England and Wales. [www.besca.org.uk](http://www.besca.org.uk)
- NAPIT - National Association for Professional Inspectors and Testers Certification Limited, [www.napit.org.uk](http://www.napit.org.uk)
- NICEIC - National Inspection Council for Electrical Installation Certification, [www.niceic.org.uk](http://www.niceic.org.uk)
- OFTEC - Oil Firing Technical Association Ltd, [www.oftec.org.uk](http://www.oftec.org.uk)

Scottish and Northern Ireland Plumbing Employers Federation (SNIPEF) [www.snipef.org](http://www.snipef.org)

The Stationery Office: [www.tsoshop.co.uk](http://www.tsoshop.co.uk)

## Appendix A Checklist for oil storage tanks

Completing this checklist will help you decide if you need to improve your oil storage facilities to comply with the Oil Storage Regulations (OSR) England and Scotland. If you're not sure of the answer, don't guess – get professional help and advice.

If your tank is exempt from the OSR, we recommend you follow these guidelines as fully as possible to reduce the risk of your oil causing pollution. There are other requirements for the Building Regulations that you tank may need to comply with. Check with your local authority for details.

For each time your answer is an ✖ refer to the guidance or contact your registered tank manufacturer, registered, competent technician, delivery company or us to find how to correct this point.

<b>General requirements</b>	<b>✖ or ✓</b>	<b>Comments</b>
Is the tank 'fit for purpose' and in good condition (unlikely to leak or burst in ordinary use)?		e.g. polyethylene isn't deformed or cracked, e.g. metal isn't rusty
Is the tank situated more than 10m from a watercourse or 50m from a well or borehole? If unsure, contact us.		
Is the tank within a secondary containment system?		
Is the tank/containment system located or protected so an impact or collision can't damage it?		
<b>Secondary containment: storage capacity</b>	<b>✖ or ✓</b>	<b>Comments</b>
For a single tank, is the secondary containment at least 110% of the maximum storage capacity of the tank?		See calculation table, page 18
For two or more tanks in one secondary containment system, is the secondary containment at least 110% of the biggest tank's maximum storage capacity, or 25% of the total maximum storage capacity of all the tanks, whichever is the greatest?		
<b>Secondary containment: integrity</b>	<b>✖ or ✓</b>	<b>Comments</b>
Is the secondary containment impermeable to water and oil?		For masonry, concrete and steel containment
Is the secondary containment system intact and without openings or valves for drainage?		Get any cracks or other damage repaired.
Are any draw-off pipes/feed lines and fill pipes that pass through the secondary containment sealed adequately?		
<b>Tank ancillary equipment</b>	<b>✖ or ✓</b>	<b>Comments</b>
Are all valves, sight gauges, vent pipes and taps within the secondary containment system?		
If the tank has a sight gauge, is it properly supported and fitted with a British Standard valve that closes automatically when the gauge isn't in use?		

Are fill and draw-off pipes/feed lines located or protected from impact or collision damage?		
And, if applicable, are they protected from corrosion and frost damage?		
And, if above ground, are they supported properly?		
Are vent pipes, taps and valves arranged so that any oil lost will be retained within the containment system?		
Are all taps and valves fixed to the storage tank, through which oil can be discharged to the open, fitted with locks and locked shut when not in use?		
<b>Deliveries to the tank (filling)</b>	<b>* or ✓</b>	<b>Comments</b>
Is the fill pipe situated within the secondary containment system or, if not, is a drip tray big enough to contain any oil that remains in the pipework after filling available?		Empty the drip tray after the tank is filled.
Can the tank and vent be seen from the point where the filling operation is controlled or, if not, is the tank fitted with an automatic overfill prevention device?		
If the tank has a screw fitting or other fixed coupling, is it in good condition?		
Are fittings/couplings being used when the tank is filled?		You need to discuss this with your oil supplier.
<b>Underground pipes (for filling and/or draw off)</b>	<b>* or ✓</b>	<b>Comments</b>
Are underground pipes for filling, draw-off or feed protected from physical damage?		
Are all mechanical joints situated as a place accessible for inspection?		For example, under a hatch or cover.
Are there adequate facilities for detecting leaks?		
If permanent leak detection is provided, is it maintained in working order and tested at appropriate intervals?		
If permanent leak detection isn't provided, have the pipes been tested before use?		
Is pipework with mechanical joints tested for leaks every five years?		
Is all other pipework tested for leaks every ten years?		

<b>Flexible draw-off pipes (for draw off)</b>	<b>* or ✓</b>	<b>Comments</b>
Is the flexible draw-off pipe fitted with a tap, valve or nozzle at the delivery end that closes automatically when not in use?		If the tap or valve can be fixed in the open position, it should have an automatic shut-off device.
Is the pipe kept within the secondary containment system when not in use or enclosed in a secure cabinet equipped with a drip tray?		
Is there a lockable valve where the pipe leaves the container which is locked shut when not in use?		
<b>Pumped draw-off (non-gravity draw-off)</b>	<b>* or ✓</b>	<b>Comments</b>
Is the pump fitted with a check valve in the feed line to the pump?		
Is the pump protected from unauthorised use and locked or isolated when not in use?		
Is the pump located or protected from impact or collision damage?		

If you can't answer a question or have crosses in the second column, it's likely that your oil storage installation needs to be upgraded to comply with the OSR unless it is exempt. The OSR England are fully in force and you must upgrade your oil storage now. To avoid the risk of pollution, take action to upgrade your oil storage as soon as possible.

## Appendix B Calculation of capacity for tanks in open secondary containment systems

We've included this so you can check your existing secondary containment meets the minimum requirements of the OSR.

Calculate the capacity of a tank located within an existing open containment system by making the measurements shown in the table below. If the tank supports, or the primary tank, take up significant space, take this into account in the calculation.

Where the tank is enclosed within a proprietary system, refer to the manufacturer for this information.

Calculation	Result	
Maximum capacity of primary tank(s) If unknown, use tank length x width x depth in metres and multiply by 1,000 to convert to litres.	..... litres	A
Containment capacity = length x width x depth of secondary container in metres.	..... m3	
Then multiply by 1,000 to convert to litres	..... litres	B
Volume lost in secondary containment by tank supports (if significant) in cubic metres.	..... m3	
Then multiply by 1,000 to convert to litres	..... litres	C
Actual containment capacity = B – C (C = 0 if tank supports don't occupy a significant volume).	..... litres	D
Minimum containment capacity (110%) = (110/100) x A	..... litres	E

If D is equal or greater than E, then the containment system volume is adequate and will comply with the OSR. We may require additional containment volume in some environmentally sensitive situations.

If D is less than E, then the containment system capacity is insufficient and will not comply with the OSR.

For installations where the tank takes up a significant part of the bund, the capacity available in the event of overfilling may be inadequate. You'll need to consider delivery procedures and alarm systems to manage this risk.

We welcome any questions or comments about this guidance, or suggestions about how we could improve it. Please email us at [pollution.prevention@environment-agency.gov.uk](mailto:pollution.prevention@environment-agency.gov.uk), phone us on 08708 506 506 or write to us at:

Environment Agency  
 99 Parkway Avenue  
 Sheffield  
 S9 4WG.

This PPG is next due to be reviewed by July 2016.

UK wide Incident/Pollution hotline 0800 80 70 60 (24 hrs)		
Floodline (England, Wales and Scotland) 0845 988 1188		flooding incident line (NI) 0300 2000 100
Environment Agency	Scottish Environment Protection Agency	Northern Ireland Environment Agency
<a href="http://www.environment-agency.gov.uk">www.environment-agency.gov.uk</a>	<a href="http://www.sepa.org.uk">www.sepa.org.uk</a>	<a href="http://www.ni-environment.gov.uk">www.ni-environment.gov.uk</a>
HEAD OFFICE Horizon House Deanery Road, Bristol BS1 5AH	CORPORATE OFFICE Erskine Court The Castle Business Park Stirling FK9 4TR	HEAD OFFICE Klondyke Building Cromac Avenue Gasworks Business Park Lower Ormeau Road Belfast BT7 2JA
Tel: 0117 934 4001	Tel: 01786 457 700 Fax: 01786 446 885	Tel: 0845 302 0008
<a href="mailto:Pollution.prevention@environment-agency.gov.uk">Pollution.prevention@environment-agency.gov.uk</a>	<a href="mailto:netregs@sepa.org.uk">netregs@sepa.org.uk</a>	<a href="mailto:NIEAPollutionPrevention@doeni.gov.uk">NIEAPollutionPrevention@doeni.gov.uk</a>

**PMHO0811BUCR-E-E**