

## Stormbloc® Optimum

### Surface Water Geocellular Storage/Infiltration System

Stormbloc® Optimum is a resilient geocellular storage system that provides underground storage and infiltration of urban runoff.

Stormbloc® Optimum is modular and easily customisable, giving you the freedom to configure storage for even the most challenging SuDS projects.

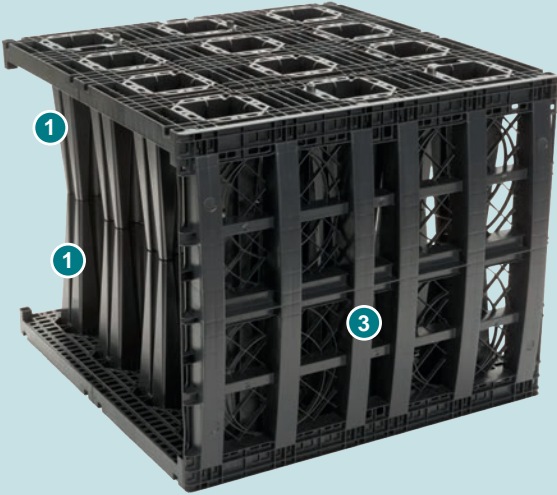

### Stormbloc® Optimum Components

The standard Stormbloc® Optimum block consists of three main elements. These elements fit together with integral snap connectors and are easily and quickly assembled.

Shallow or variable depths can also be achieved by using just one basic element and a cover plate creating a half block which gives a layer of 360 mm.

1. Basic element.
2. Cover plate.
3. Side plate.



*Figure 1 - Stormbloc® Optimum components.*

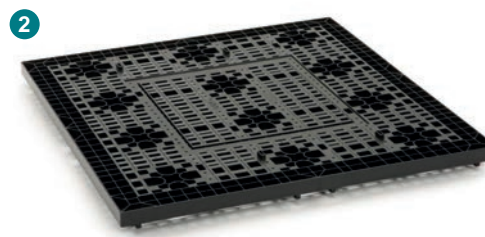
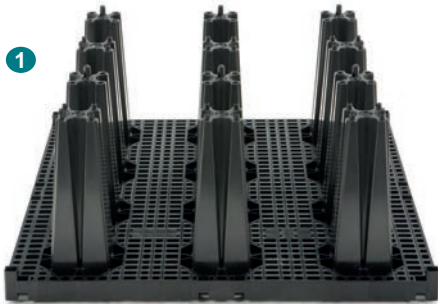

## Benefits

### Customise Your Storage

Length, width and depth of storage can be customised in order to meet even the most demanding of drainage environments. Two inspection channels enable easy inspection and maintenance.

### Save Space On Site

Stormbloc® Optimum stacks into compact nests for transportation and storage, saving valuable space during transport and on site. With up to 75% space reduction, a double pallet of stacked, nested boxes delivers more than 14 m<sup>3</sup> of stormwater storage, and a single lorry delivery can provide 345 m<sup>3</sup>.

### Lightweight and Strong

Combining strength with a storage coefficient of 96%, Stormbloc® Optimum allows you to plan and design effective SuDS systems even in challenging urban environments with high traffic levels.

## Dimensions, Capacity and Strength

	Stormbloc® Optimum Full Block	Stormbloc® Optimum Half Block
<b>Material</b>	Polypropylene	Polypropylene
	Stormbloc® Optimum is manufactured from approved recycled polypropylene. Due to its long life and minor maintenance requirements, there is a reduced need for recycling during its life span. At the end of the life cycle, Stormbloc® Optimum can be recycled safely at minimal risk to the environment.	
<b>Length / Width / Height</b>	800 / 800 / 660 mm	800 / 800 / 360 mm
<b>Constructed Block Weight</b>	18.6 kg	13.7 kg
<b>Nominal Block Volume</b>	0.422 m <sup>3</sup>	0.230 m <sup>3</sup>
<b>Nominal Storage Capacity per Unit</b>	0.405 m <sup>3</sup>	0.221 m <sup>3</sup>
<b>Porosity</b>	96%	96%
<b>Vertical Ultimate Compressive Strength</b>	≥ 420 kN/m <sup>2</sup>	≥ 420 kN/m <sup>2</sup>
<b>Horizontal Ultimate Compressive Strength</b>	≥ 165 kN/m <sup>2</sup>	≥ 225 kN/m <sup>2</sup>

Table 1 - Stormbloc® Optimum technical data.

## Structural Testing

Stormbloc® Optimum has undergone extensive 3rd party structural testing and FEA modelling to ensure that it is capable of withstanding the high loading forces that are likely to occur under heavily trafficked areas, as well as long term loading imposed by the ground cover above the system.

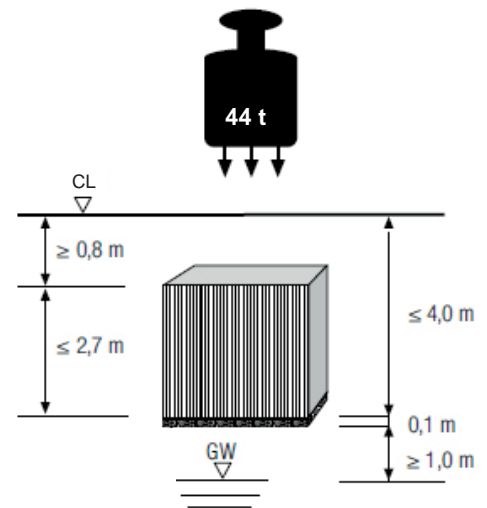

## Expert Design Service

Hydro's professional engineers are on hand to provide free support for Stormbloc® Optimum storage / infiltration tank design.

**Call +44 (0)1275 337977 or email [stormwater@hydro-int.com](mailto:stormwater@hydro-int.com)**

## Detail Design

Hydro International offers a free outline design service, ensuring the most efficient and cost-effective solution for infiltration / soakaway and storage structures. A further, more detailed Hydrological Analysis service is also available if required.

The use of good engineering practice and awareness of the limitations of all materials used will avoid construction and operational problems. Hydro International has an expert and dedicated workforce capable of providing advice on many aspects of system design.

## 1. Storage Volume Calculation

The system designer needs to calculate the volume of storage required. There are a number of suitable methods that can be used to calculate the storage volume. These vary from relatively simple manual methods to sophisticated simulation models.

As part of Hydro International's free design service we offer an estimated storage volume using the industry standard drainage modelling software suite: MicroDrainage®.

General design guidance on modelling of Stormbloc® Optimum and Hydro-Brake® Optimum vortex flow controls can also be found on our website: [hydro-int.com/resources](http://hydro-int.com/resources).

## Design Requirements

To be able to carry out storage calculations we require the following, site specific information:

### Infiltration Systems

1. Design Return Period
2. Site Location
3. Drained Impermeable Area
4. Soil Infiltration Rate\*

### Storage Systems

1. Design Return Period
2. Site Location
3. Drained Impermeable Area
4. Maximum Allowable Discharge Rate

\* The soil infiltration rate should be derived from a site porosity test using a recognised method (eg. BRE digest 365).

## 2. Location and Layout

Consider the most appropriate and cost-effective location for the infiltration/storage facility. The flexibility afforded by Stormbloc® Optimum combined with the substantial reduction in volume required (when compared with gravel pits for instance) allows the design of storage into locations that would be impractical for traditional systems.

Due to the modular nature of the system, Stormbloc® Optimum can be assembled to virtually any size, shape, depth or configuration and obstructions such as trees, pipework and rock outcrops can easily be circumvented.

Pipe connections can be made from multiple directions into the Stormbloc® Optimum system. Inspection / maintenance chambers should be made at critical points (eg. inlet, change of flow direction) to provide a continuous flow path through the system regardless of changes of flow direction.

The Stormbloc® Optimum system can be installed practically anywhere including under roads, footpaths, car parks, public open spaces, landscaped areas, gardens, tennis courts and playing fields.

For infiltration systems consideration should be given to the soil conditions of the intended location of the tank. The soil should have a suitable percolation rate (typically > 0.05 m/hr), should be free of contaminants and should not have a high groundwater level.

### 3. Depth and Dimension of the System

The Stormbloc® Optimum system is highly flexible and allows the system designer to consider a range of options not normally available with other storage systems. There are, however, certain limiting factors that need to be considered:

#### 3.1 Depth of Subgrade Layer

The base of the excavation should form a sound working platform and have a sand or gravel subgrade layer to provide a level support base for the system. This should be at least 100 mm deep and be flat and even. Extra care should be given to this subgrade layer for larger installations, and in particular for multilayered designs.

#### 3.2 Lateral Loadings

The maximum depth to the base of the units is limited by the lateral (sideways) pressure that acts on the units. This is due to earth and water pressure and the effects of surcharges on the surface. The exact pressure from groundwater should be assessed on a site-by-site basis if groundwater is present above the base of the units.

#### 3.3 Depth to Base

If the depth to the base of the system is greater than 4.0 m, please contact Hydro International for specific design assistance. Deeper installations may be possible under certain conditions.

#### 3.4 Backfill / Cover

Stormbloc® Optimum should be installed with a minimum depth of cover of 400 mm under landscaped / non-trafficked areas to protect from damage with gardening or agricultural implements.

For installations where the system will be subject to loading from traffic the depth of cover should allow the dispersion of surface loading (in particular point loads) such that the loading to the top of the Stormbloc® Optimum is distributed evenly. The material should be carefully compacted in layers to form a depth to suit the maximum expected loads.

As a general guide the following depths of ground cover above the Stormbloc® Optimum modules should be adhered to according to the likely traffic loading.

	Traffic Loading		
	Landscaped Area with No Access for Vehicular Traffic	Car Parks with Traffic Loading of 2.5 t	Roads and HGV Loading Yards with Traffic Loading < 44 t
Coverage C (m)	$C \geq 0.4$	$C \geq 0.6$	$C \geq 0.8$
Installation Depth D (m)	$D \leq 4.0$	$D \leq 4.0$	$D \leq 4.0$
Height H of System (m)	$0.36 \leq H \leq 2.64$	$0.36 \leq H \leq 2.64$	$0.36 \leq H \leq 2.64$
Groundwater	None	None	None

Table 2 - Stormbloc® Optimum traffic loading parameters.

**The actual loading rate on the modules should always be checked by the system designer.**

The material used for the construction above the Stormbloc® Optimum system should be selected according to the surface loadings. A non-angular granular material (nominally 100 mm thick) should be used immediately next to the geotextile or membrane surrounding the system so as to protect it from puncturing. Alternatively a geotextile fleece may be used.

# Design Data

## Stormbloc® Optimum

### Surface Water Geocellular Storage/Infiltration System

---

#### 3.4 Gradient

Stormbloc® Optimum can be laid to a gradient to aid the flow of stormwater through the system. Stormbloc® Optimum has, however, been designed and developed to provide resistance to loads applied predominantly in the vertical plane. Laying Stormbloc® Optimum to a gradient will therefore slightly reduce the transient and long term loads that the system can withstand. Gradients of 1:100 should generally not be exceeded.

#### 3.5 Flotation

If it is necessary to install a Stormbloc® Optimum system within the groundwater table then flotation needs to be considered. In simple terms, there needs to be a greater force acting over the system (ie. the weight of the backfill) to compensate for the up-thrust caused by buoyancy. This should be checked by a suitably qualified and experienced engineer.

If the system is installed within the groundwater table it is advisable that encapsulation of the system is carried out to ensure the system is 100% watertight. Failure to do so could reduce the available storage capacity of the Stormbloc® Optimum system.

## 4. Designing the Stormbloc® Optimum Tank

The Stormbloc® Optimum system comprises of 6 different components:

- 4.1 Stormbloc® Optimum Blocks
- 4.2 Pipe Adaptors
- 4.3 Access Chambers
- 4.4 Catchpits
- 4.5 Inlet and Outlets
- 4.6 Geotextiles and Geomembranes

#### 4.1 Stormbloc® Optimum Blocks

The main infiltration or storage tank is comprised of Stormbloc® Optimum modules in a configuration to suit the location. A single 0.8 m x 0.8 m x 0.66 m module holds 0.405 m<sup>3</sup> of stormwater and so the design should incorporate a sufficient number of blocks to provide the required volume.

The base layer should be laid directly onto the geotextile or membrane. The blocks should be laid such that the tunnels are in line, creating access through the system.

The two available block sizes offer a high level of flexibility in the design and depth of the system. If a combination of full blocks (660 mm deep) and half blocks (360 mm deep) are being used then the half blocks must form the top layer of the system

#### **Example:**

**If 85 m<sup>3</sup> is required then the number of modules to be used can be calculated as follows:**

$$85 \div 0.405 = 209.88$$

**210 No. Stormbloc® Optimum modules should be used.**

**These could be arranged in the configuration:**

$$12 \text{ m} \times 5.6 \text{ m} \times 1.32 \text{ m}$$

**(15 modules long x 7 modules wide x 2 modules deep)**

# Design Data

## Stormbloc® Optimum

### Surface Water Geocellular Storage/Infiltration System

---

#### 4.2 Side Plates and Pipe Adaptors

All tank sides should be covered with a side plate to prevent backfill entering the modules. Where pipe connections are required adaptors are provided depending on the size of pipe used.

Side plates are used where no pipe entry is required into a tunnel. These plates simply snap into position and take seconds to locate

Stormbloc® Optimum Connection Adaptors DN150, DN225 and DN300/450 are available for a direct connection to a Stormbloc® Optimum block.

The DN300/450 step adaptor simply replaces the Side Plate where a pipe connection needs to be made. The adaptor needs to be cut on site to the required diameter. Then a coupling sleeve attaches the pipe to the adaptor.

Smaller adaptors for DN150 and DN225 attach to the side plate itself. The adaptors can be fitted into any of the four quadrants to suit the level of the incoming pipe. These adaptors are sockets allowing the pipe to be fully inserted and sealed.



Figure 2 - Stormbloc® Optimum side plate.

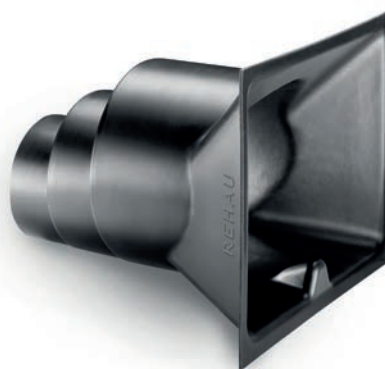

Figure 3 - Stormbloc® Optimum DN300/450 pipe adaptor.



Figure 4 - DN150 pipe adaptor



Figure 5 - DN225 pipe adaptor

# Design Data

## Stormbloc® Optimum

### Surface Water Geocellular Storage/Infiltration System

---

#### 4.3 Stormbloc® Optimum Inspect Modules

The Stormbloc® Optimum Inspect offers an unrivalled level of accessibility to any Stormbloc® Optimum installation. This modular access chamber, sited within the tank, has identical dimensions to a Stormbloc® Optimum module and so can be easily incorporated into the layout of the infiltration or storage system.

Each Stormbloc® Optimum Inspect module offers connection points on all four sides for direct access to the inspection tunnels on the Stormbloc® Optimum modules or for connection of inlet and outlet pipes to the system at any point.

#### Advantages:

- The Stormbloc® Optimum Inspect has the same dimensions as the Stormbloc® Optimum modules and is fully stackable.
- Can be integrated within all Stormbloc® Optimum installations.
- The volume of Stormbloc® Optimum Inspect contributes to the required storage capacity.
- High and low level inlet connections possible.
- Can accept inlet / outlet connections up to 450 mm internal diameter.
- Enables optimum accessibility for inspection and maintenance.
- Excellent access to the installation via 500 mm internal diameter extension shaft to ground level.
- Reduces the need for separate manhole chambers.
- The use of a standard vented manhole cover in conjunction with the Stormbloc® Optimum Inspect unit removes the need for separate ventilation structures.
- Reduces installation time.
- Reduces capital costs on overall project.



Figure 6 - Stormbloc® Optimum Inspect



Figure 7 - CCTV camera

# Design Data

## Stormbloc® Optimum

### Surface Water Geocellular Storage/Infiltration System

---

#### 4.4 Catchpits

The Stormbloc® Optimum system is directly accessible for maintenance and inspection via the channels within each block. Access to these tunnels should be provided from a suitable location on the surface, such as via access chambers, manholes, rodding points or Stormbloc® Optimum Inspect Chambers.

Traditional catchpits or silt traps are not very effective at preventing finer particles from entering any system and any trapped material can often be re-entrained during subsequent storm events and passed into the infiltration or storage media. It is, however, still good practice to include catchpits / silt traps prior to any infiltration or storage system. Any chambers or manholes immediately upstream of a Stormbloc® Optimum installation should preferably be built as catchpits or silt traps to capture larger or settleable material.

If required a complete treatment train approach can be provided with the use of the **Downstream Defender®**, **First Defense®**, **Up-Flo™ Filter** and **Hydro Biofilter™** products which remove a wide range of pollutants including floatable debris, sediments, nutrients, metals, oils, grease organics and bacteria (see below).

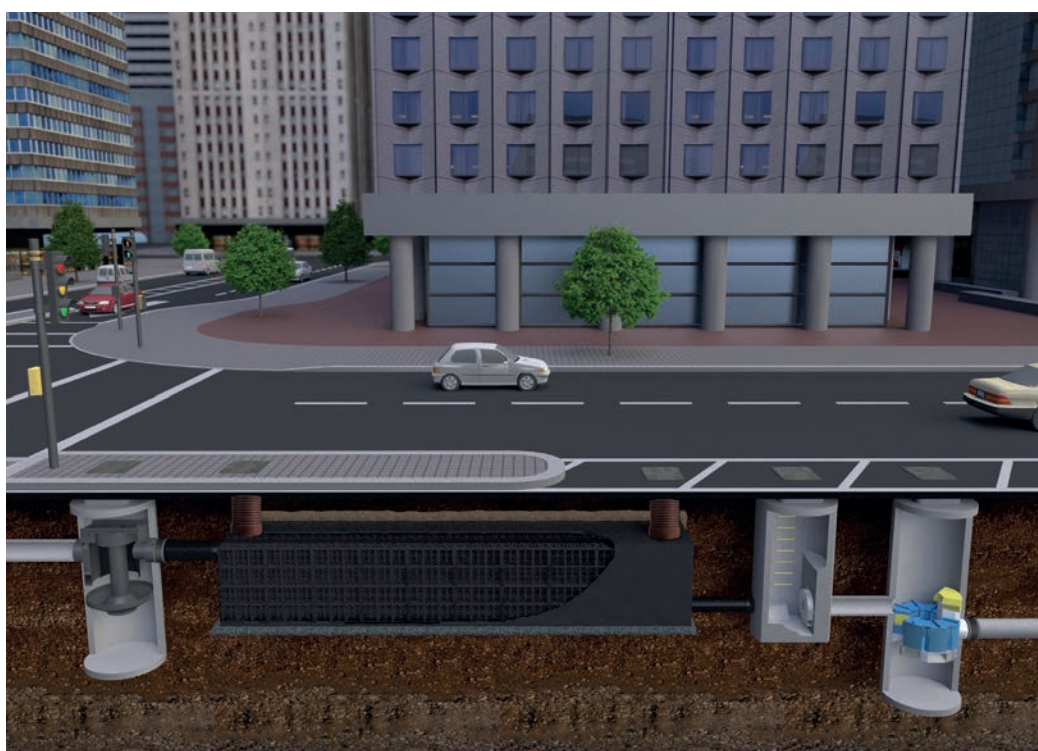

Figure 7 - Hydro International's complete Stormwater Management System.

#### 4.5 Inlet, Outlet and Vent Pipe Requirements

The size and number of pipes being connected to the system should be sufficient to be able to convey the maximum expected flow rates from the site into the modules without restriction. Typically the inlet pipes (and outlet pipes for an on-line storage system) will be connected to the lower tunnel on the modules and a vent pipe will be connected to the upper tunnel.

A vent allows displaced air to escape the Stormbloc® Optimum System. Adequate venting must be provided to the Stormbloc® Optimum structure, either through high level pipe connections between the units, through direct venting to the atmosphere or via Stormbloc® Optimum Inspect chambers which render separate venting systems unnecessary provided ventilated covers are used.

If the system does not include a Stormbloc® Optimum Inspect Chamber or high level pipe, a ventilation plate is available for this purpose. As a general rule of thumb the number of 100 mm diameter vent pipes required should equal the number of inlet pipes entering the Stormbloc® Optimum system.

# Design Data

## Stormbloc® Optimum

### Surface Water Geocellular Storage/Infiltration System

---

#### 4.6 Geotextile and Membrane Protection

Depending upon the application, the entire system should be wrapped with either a suitable geotextile (for infiltration) or an impermeable membrane (for storage / attenuation). There is a great degree of variation in the physical properties of available geotextiles and membranes, which should be selected according to specific site conditions.

For installations where there is a risk of contaminants within the surrounding ground or where the groundwater level is above the base of the system advice on suitable membrane with welded joints should be sought from a specialist supplier (please contact Hydro International directly if you require a list of independent membrane specialists who have previous experience of Stormbloc® Optimum installations).

## 5. Maintenance Instructions

The channels within each Stormbloc® Optimum module allows almost the entire volume of the construct to be inspected via CCTV camera and flushed through.

A catchpit chamber immediately upstream of the system is recommended as this will reduce the amount of silt entering the installation. For larger installations it may also be advantageous to add further catchpits to the system design or an advanced vortex silt trap such as the **Downstream Defender®** by Hydro International. The collection sump(s) should not be allowed to overfill as this will lead to silt carry-over into the Stormbloc® Optimum modules.

As all schemes are different, the frequency at which the catchpit(s) should be emptied will need to be determined on site. For small soakaways and individual infiltration tanks it will generally only be necessary to ensure that the catchpits / silt traps are free from debris such as leaves or sediment. It is recommended that any system be inspected no less frequently than at monthly intervals for the first 3 months and thereafter at 6 monthly intervals. In addition, it is suggested that the installation is inspected immediately following the first storm event, whenever this should occur post installation.

Individual maintenance schedules should be drawn up using the information obtained from the initial inspections. It should also be noted that more regular inspections may be required should the catchpit(s) fill more frequently and/or if the initial inspections reveal that maintenance / cleaning will be required more regularly than at six month intervals.

Flushing of the system can be achieved using a jetting system with a 120 bar pressure. The jet nozzle should be introduced to the system via the access chamber / manhole and the block channel. The silt should be flushed to the access chamber or catchpit manhole and removed from there.



Figure 8 - Jetting nozzle flushing the system

## Design Data

### Stormbloc® Optimum

Surface Water Geocellular Storage/Infiltration System

Hydro International's Hydro-Brake® Flow Control Series range can help you customise and size your Stormbloc® Optimum storage to suit specific site requirements. To find out how, visit [hydro-int.com](http://hydro-int.com).

## The Hydro-Brake® Flow Control Series

### Hydro-Brake® Flood

For flood defence from small dispersed schemes to major watercourse control.

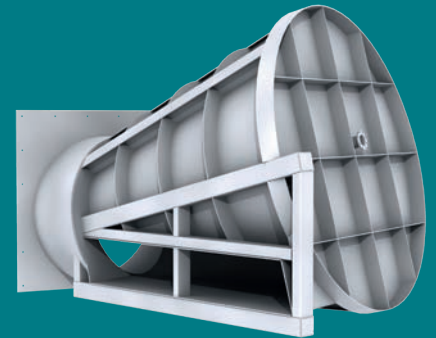

### Hydro-Brake® Optimum

For control of low, moderate and high flows with tailored performance to provide a cost and space optimised drainage design.

### Hydro-Brake® Agile

For meeting site runoff objectives for very space constrained sites.



### Hydro-Brake® Orifice

Simple, precise flow control for sites with generous discharge consents.