

Window W2 Plan Detail  
1:10

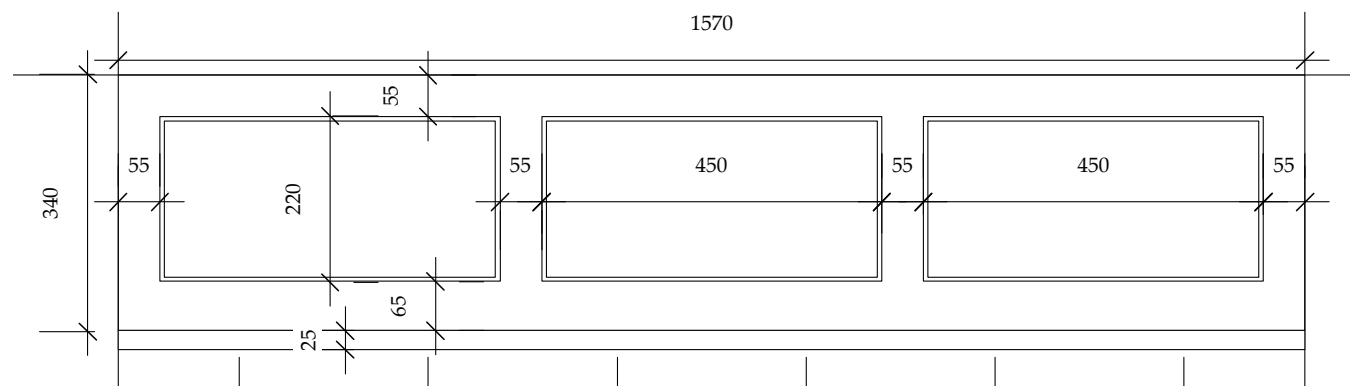

Window W2 External Elevation  
1:10

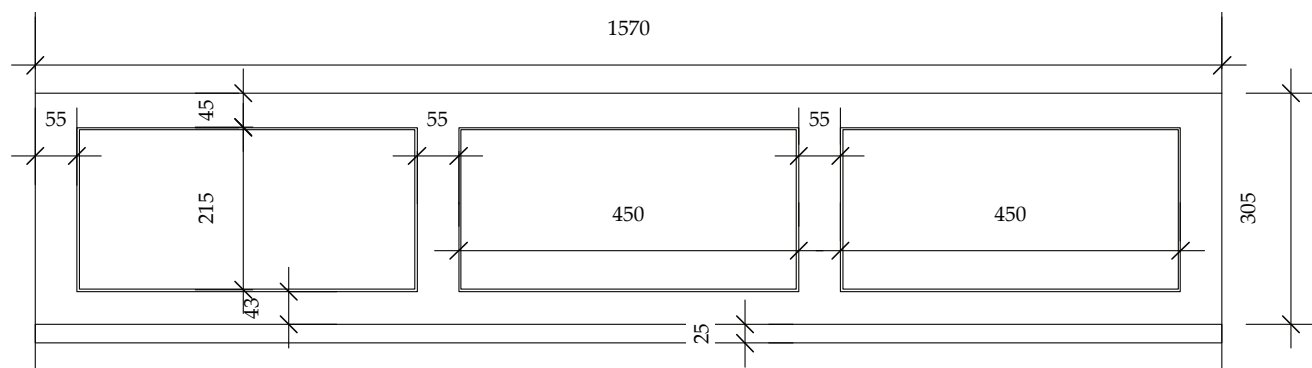

Window W2 Internal Elevation  
1:10



Scale Bar 1:10

All joinery in preservative treated softwood with painted finish, with painted hardwood cills.

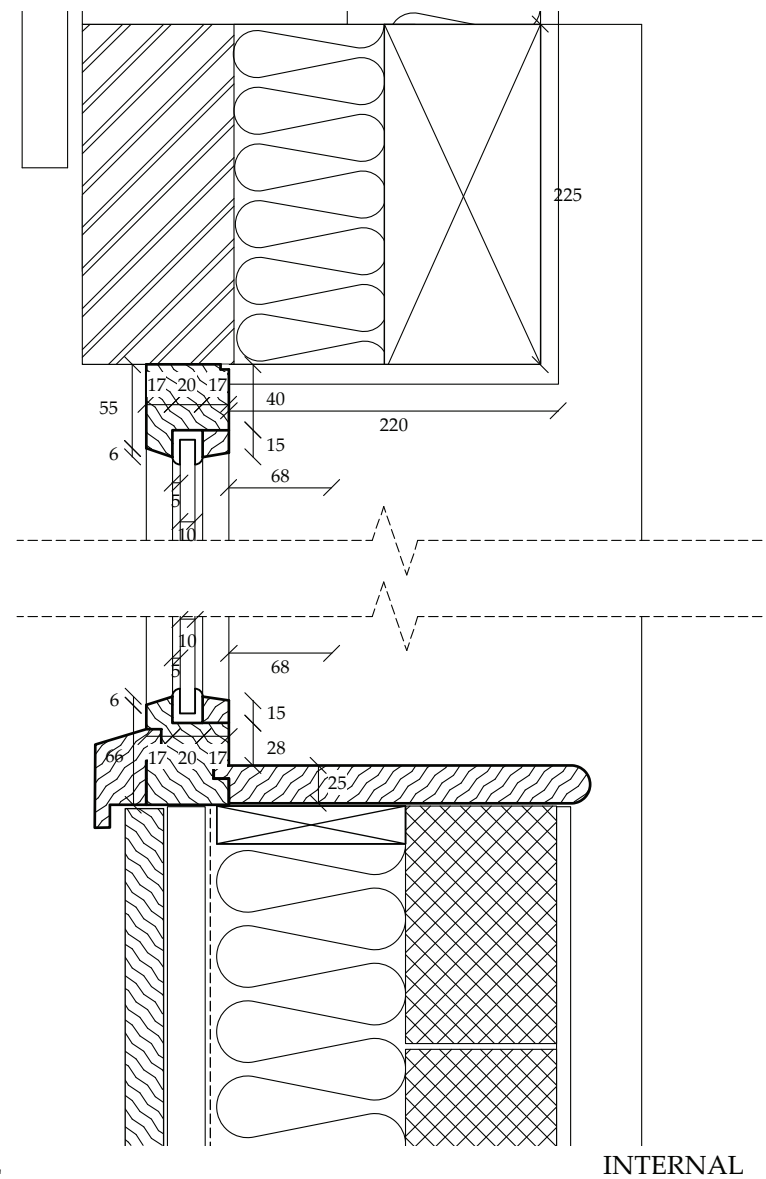

Window W2 Detail  
1:5



Scale Bar 1:5

This drawing is the copyright of Oliver Architecture Ltd.  
All dimensions are to be checked on site prior to commencing work.  
Scaled dimensions should not be taken from this drawing unless stated.  
Dimensions of new work are to be adjusted to suit the existing building as necessary.  
The contractor must not assume that the existing building is plumb, square or level.  
Prior to commencing work, all discrepancies are to be reported to the Architect.

**Revisions:**  
A 03.07.17 Metal flashing omitted, new hardwood cill added.

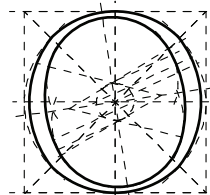

**OLIVER ARCHITECTURE LTD.**  
Bradford Court, 123-131 Bradford Street,  
Birmingham B12 0NS  
T: 0121 773 5002  
W: www.oliver-architecture.co.uk

<b>Project</b>	Epworth, Old Rectory Shop and Toilets	Scale	1:10/1:5 @ A3	Job No.	1606
		Date	June 2017	Drg. No.	125
<b>Drawing</b>	Window W2 Detail Working Drawing	Drawn	pw	Rev.	A