

INFORMATION WITHIN THIS DRAWING IS NOT NECESSARILY PRODUCED TO SCALE. ALWAYS USE FIGURED DIMENSIONS AND CO-ORDINATES - IF IN DOUBT, ASK.

NOTES

- All pipes shall be either:
  - A - Vitrifed clay to BS EN 295 with a minimum crushing strength as follows:
    - 150 dia. - 40 kN/m
    - 225 dia. - 45 kN/m
    - 300 dia. - 72 kN/m
  - B - PVC (certified to WIS 4-35-01 & BS EN 13476)
  - C - Class 120 concrete to BS 5911-1:2002/EN 1916.
- All pipes should always connect soffit to soffit unless noted otherwise.
- All pipes to have BSI Kitemark status (certified to WIS 4-35-01 & BS EN 13476). Maximum pipe length to be 3m. Plastic channel sections in manholes are not acceptable. Clay channel sections shall be used.
- Sewers to be laid in Class "S" Bedding (150mm granular bed and surround). Where depth of cover to top of the sewer is less than 1.2m in highways and verges (or less than 900mm in none vehicular access areas) then a concrete slab should be provided above granular bed and surround.
- Manhole covers shall have a clear opening of 600 and shall be class D400 to BS EN 124 with 150 deep frames in highways.
- Pipes entering manholes and road gullies shall have a flexible joint within 600 of the inside the manhole or gully joining with a short Rocker pipe.
- The adoptable sewers should be a minimum of 1m and manholes 0.5m from kerb faces and service margins.
- Sewers must have 5m clearance from trees and hedges
- All trenches in roads and paved areas shall be backfilled with Type 1 DOT granular sub-base material, or other granular material approved by the highway authority.
- Fill ground must be filled and consolidated under the supervision and to the satisfaction of Severn Trent Water before any sewer works are carried out.
- All in situ concrete to be designated mix FN2 to BS 8500-1 unless agreed otherwise.
- The invert levels at the proposed points of connection to existing public sewers shall be checked before any new drains are constructed. Any variation to the levels shown on the drawing shall be notified to Eastwood & Partners.
- The chamber size of manholes with more than one connection in them may need to be increased an increment to accommodate the connections and bends.
- Cover levels are indicative only. Covers to be set to suit camber/gradient of existing and proposed roads.
- Cover slabs must carry the BSI Kitemark or will be rejected by Severn Trent Water Inspector. Where the clear opening of the Kitemarked product is different to that of the cover and frame, a loading bearing slab should be fitted above the cover slab to bring the size down to 600mm x 600mm for the Severn Trent Water specified cover size. Please refer to Concrete Pipe Systems Association (CPSA), 'Technical Bulletin' issued Autumn 2004 for Kitemarked cover slab opening sizes.
- All foul lateral sewers and drains to be 1500 unless noted otherwise.
- Manhole covers shall have a clear opening of 600mm and shall be Class D400 to BS EN 124 with 150mm deep frames in highways.
- Where a B125 cover and frame has been approved, this must not be coated in plastic and must have lifting eyes suitably sized to accommodate standard lifting keys. Screw down covers are not acceptable.
- All adoptable sewer works and material to be in accordance with "Code for Adoption". The Relevant British/European and Severn Trent Water's Standards/Requirements/Addendum to the Mechanical and Electrical Specification and Kitemarked.
- Severn Trent Water is not obliged to accept filter drain/land drainage run-off into the public sewer network or adoptable drainage system (directly or in-directly). An alternative method of disposal of the land drainage run-off will therefore be required and you will have to liaise with the Local Authority, Land Drainage Section with regard to the disposal of the filter drain/land drainage run-off.
- Sulphate resistant cement (C20-DC2) and precast concrete products must be used or a laboratory report provided proving that such precautions are not necessary.
- Bedding and backfill material to conform to the requirement of Water Industry Specification 4-08-02 (Table A2).
- Adoptable plastic sewer pipes to be BSI Kitemarked (certified to WIS 4-35-01 and BS EN 13476). Adoptable plastic sewer pipes to be laid in maximum 3 metre lengths unless there is a specific operational need to lay longer lengths. Plastic channel sections in manholes are not acceptable and Severn Trent Water would prefer clayware channel in manholes. We have found that plastic channels are difficult to set in concrete because they float and a satisfactory finish cannot be obtained on the bedding.
- The clearance of the crossover points (min 300mm) between the surface water, foul sewers, rising main and other services should be sufficient clearance to provide 150mm surround of a certain mm that exceeds this (200mm).
- All adoptable laterals to be 1500 and VC unless stated otherwise

**NOTE:**  
For all clauses and table references please refer to the Design and Construction Guidance contained within the Code for Adoption.

A	First Issue.			
REV	DESCRIPTION	SIG	CHK	DATE

**ONGO HOMES LIMITED**  
  
**WARLEY ROAD, SCUNTHORPE**

**DRAINAGE DETAILS SHEET 2**

**Eastwood & Partners**  
CONSULTING ENGINEERS

St. Andrew's House  
23 Kingfield Road  
Sheffield  
S11 9AS  
Tel 0114 255 4554  
Fax 0114 255 4330

mail@eastwoodandpartners.com  
www.eastwoodandpartners.com

SCALE WHEN PLOTTED AT 1		DRAWING STATUS	
1:25		PRELIMINARY	
DRAWN	CHECKED	DATE	DRAWING NUMBER
CJH	AA	20/05/2022	46663/008
REV			A

**TYPICAL MANHOLE PLAN VIEW**

Type A & B (Design and Construction Guidance)

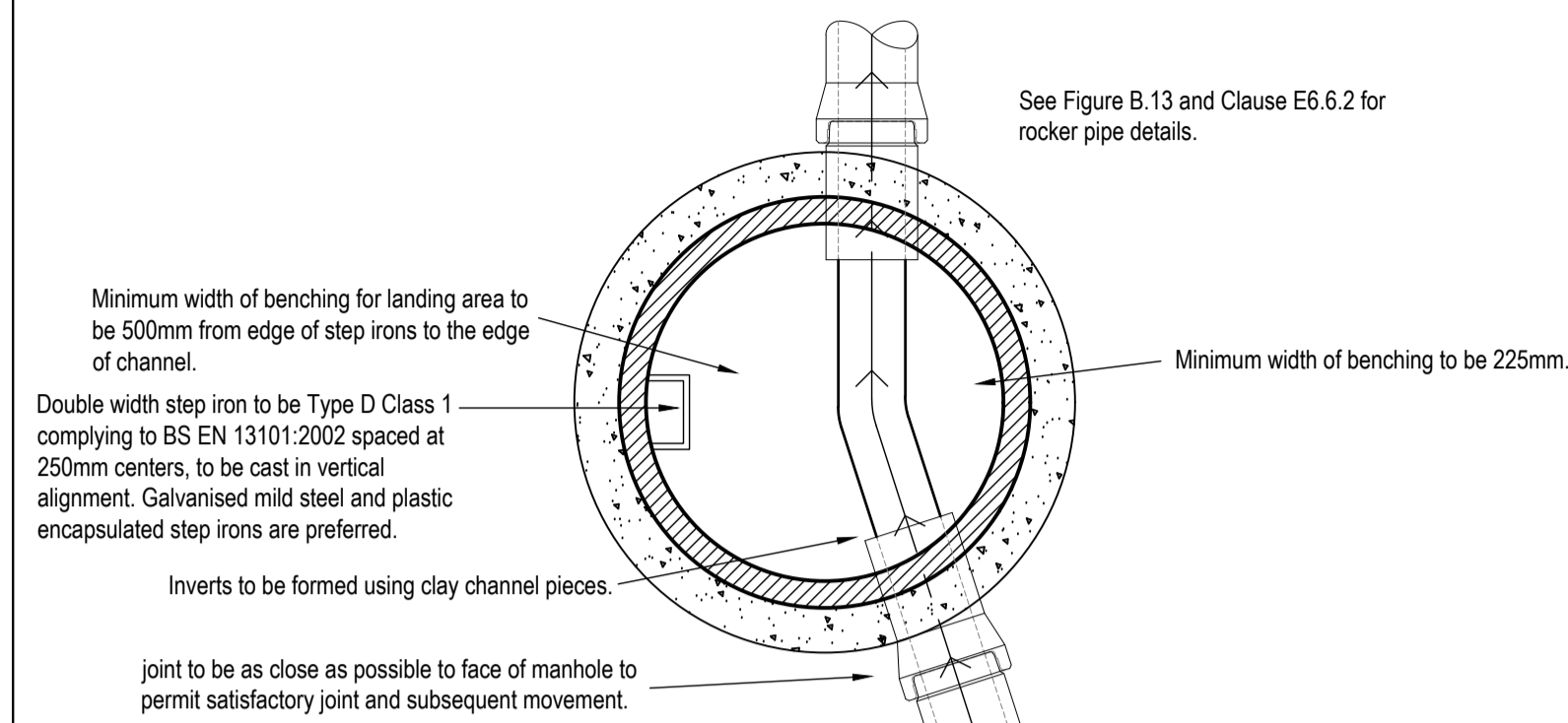

**SHALLOW MANHOLE PLAN VIEW**

Type C (Design and Construction Guidance)

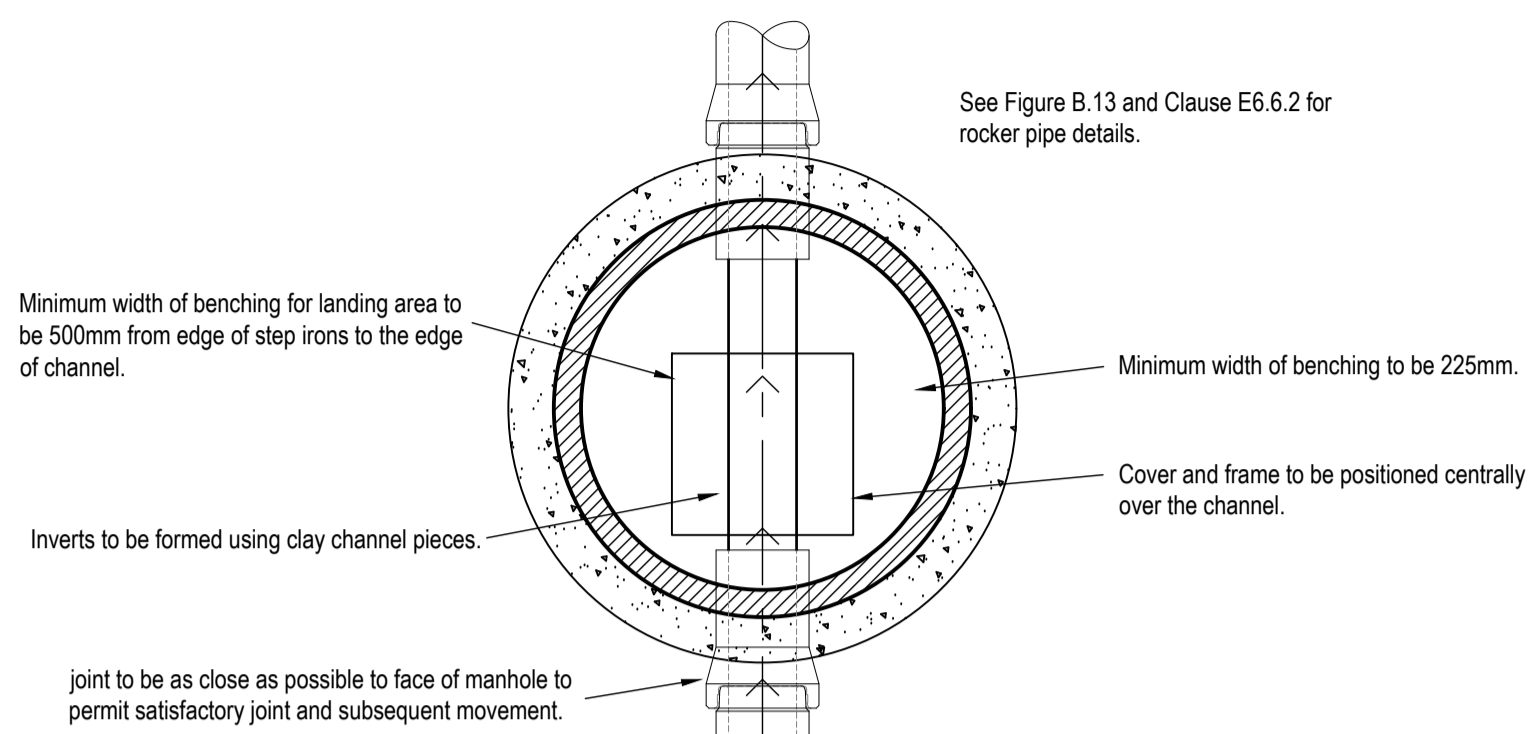

**TYPICAL WIDE WALL MANHOLE PLAN VIEW**

Type A & B (Design and Construction Guidance)

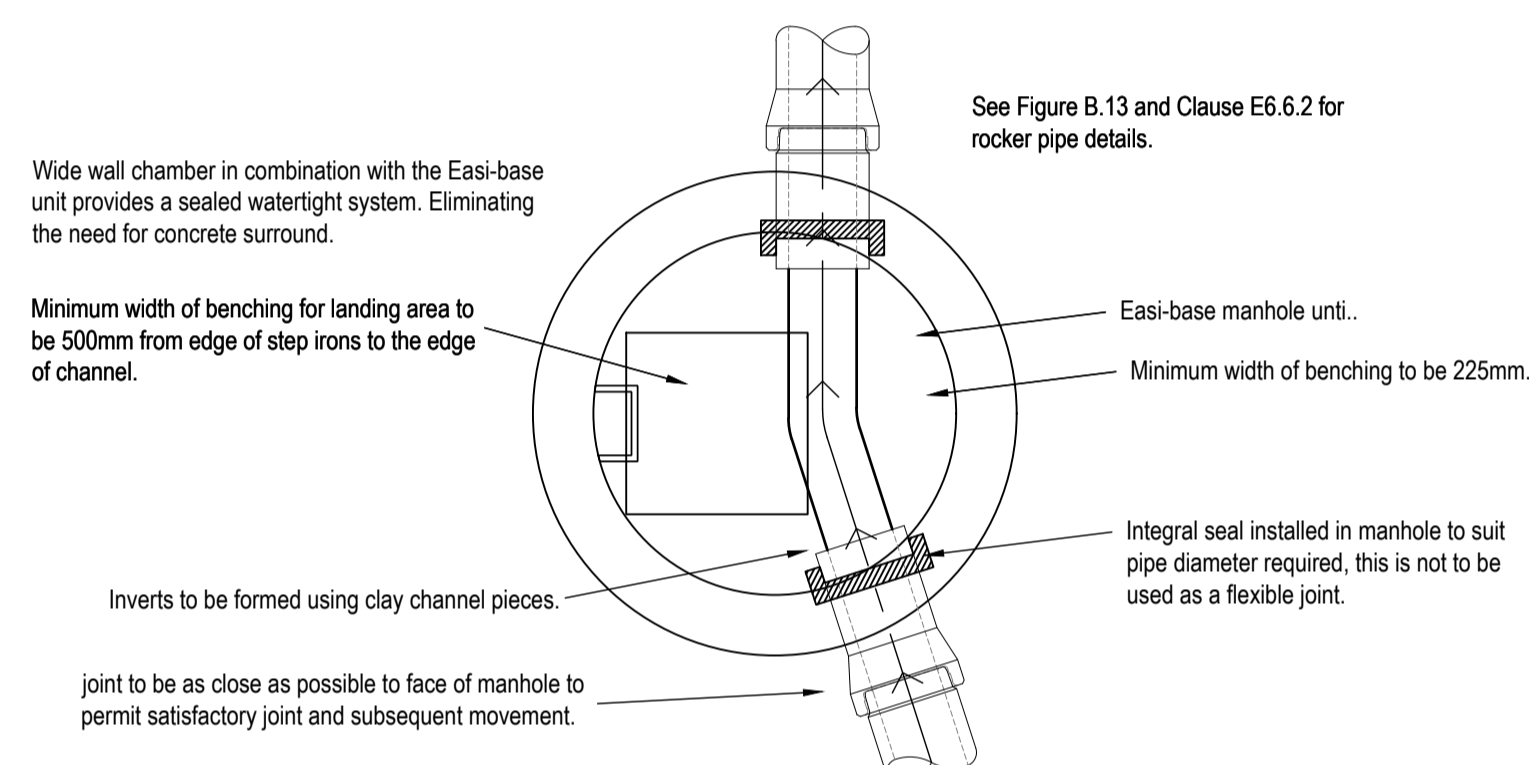

**SHALLOW MANHOLE PLAN VIEW**

Type C (Design and Construction Guidance)

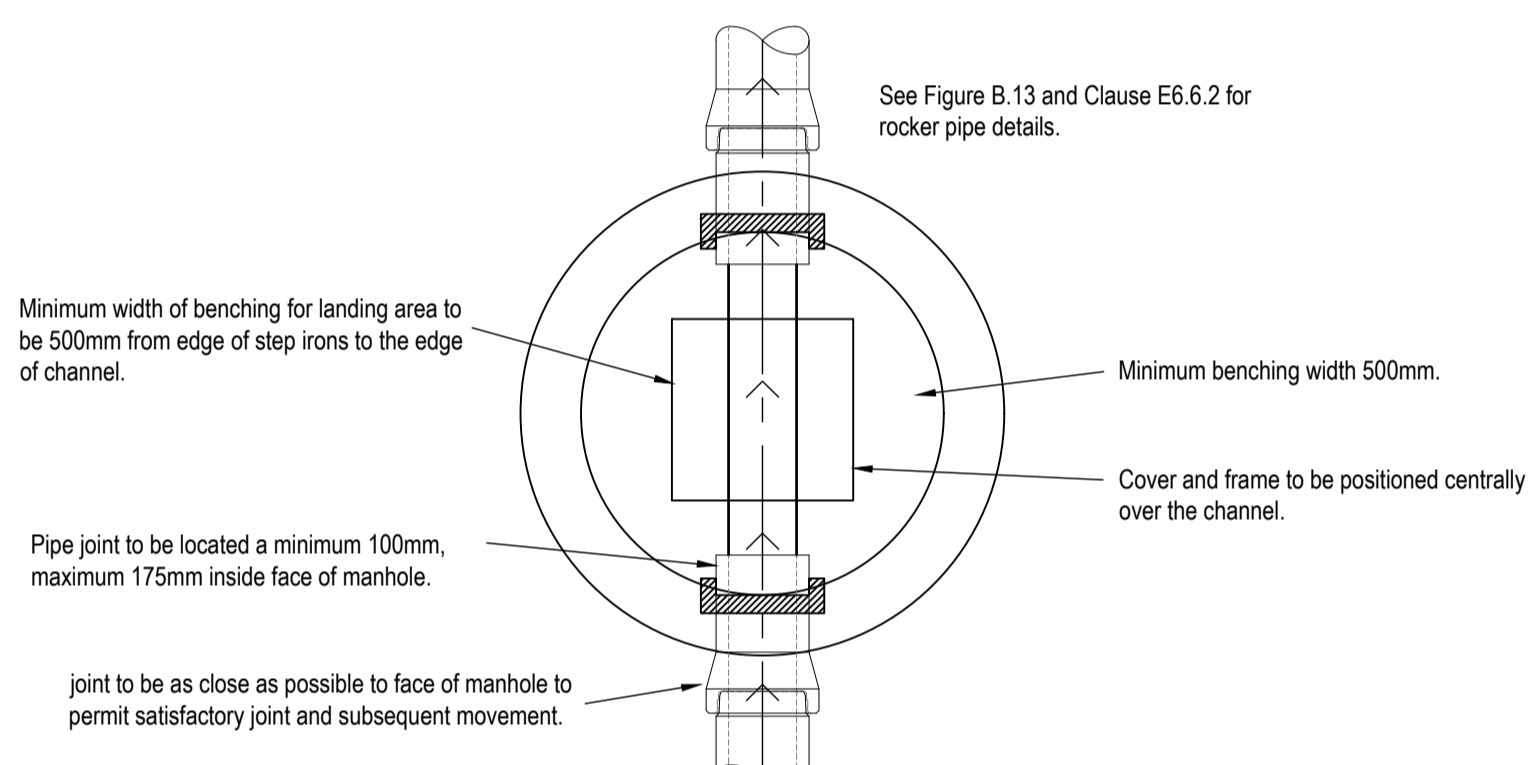

**DEMARICATION CHAMBER LOCATED IN GARDENS DETAILS**

Depth from cover level to invert level of pipe chamber greater than 1200mm (maximum depth 2000mm). Maximum lateral drain diameter 150mm.

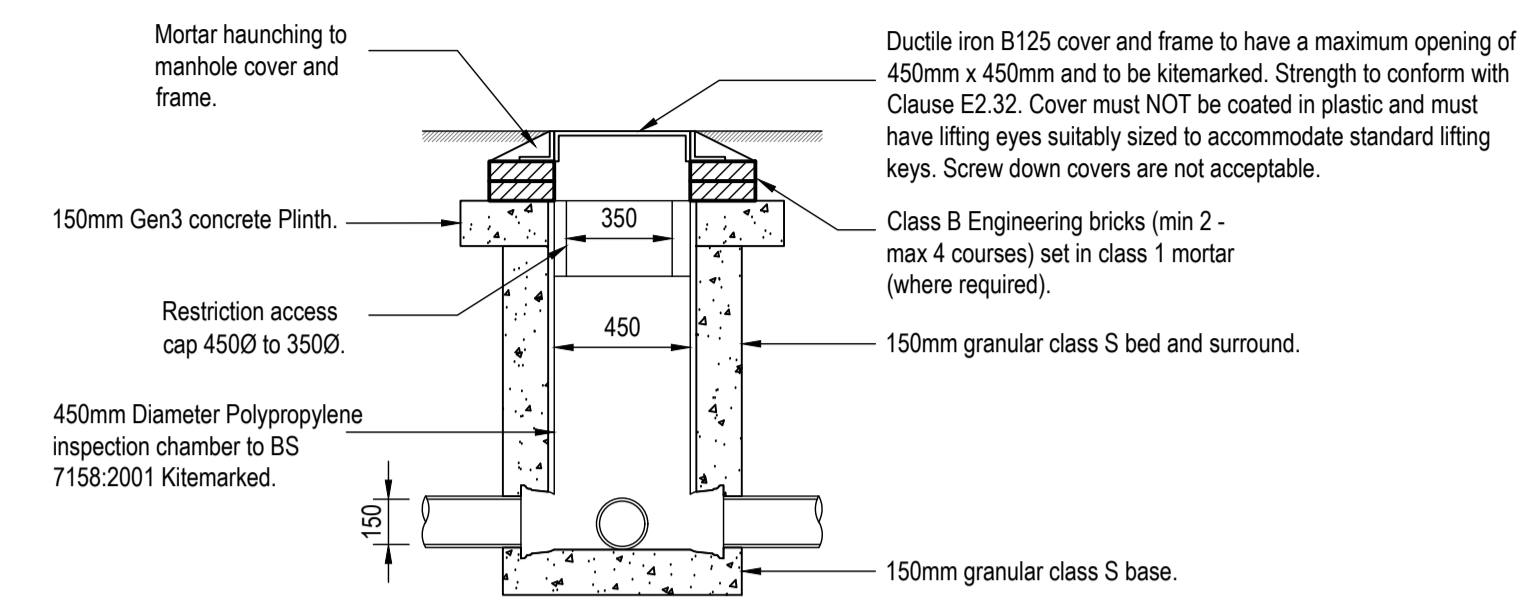

**DEMARICATION CHAMBER LOCATED IN GARDENS DETAILS**

Depth from cover level to invert level of pipe chamber less than 1200mm. Maximum lateral drain diameter 150mm.

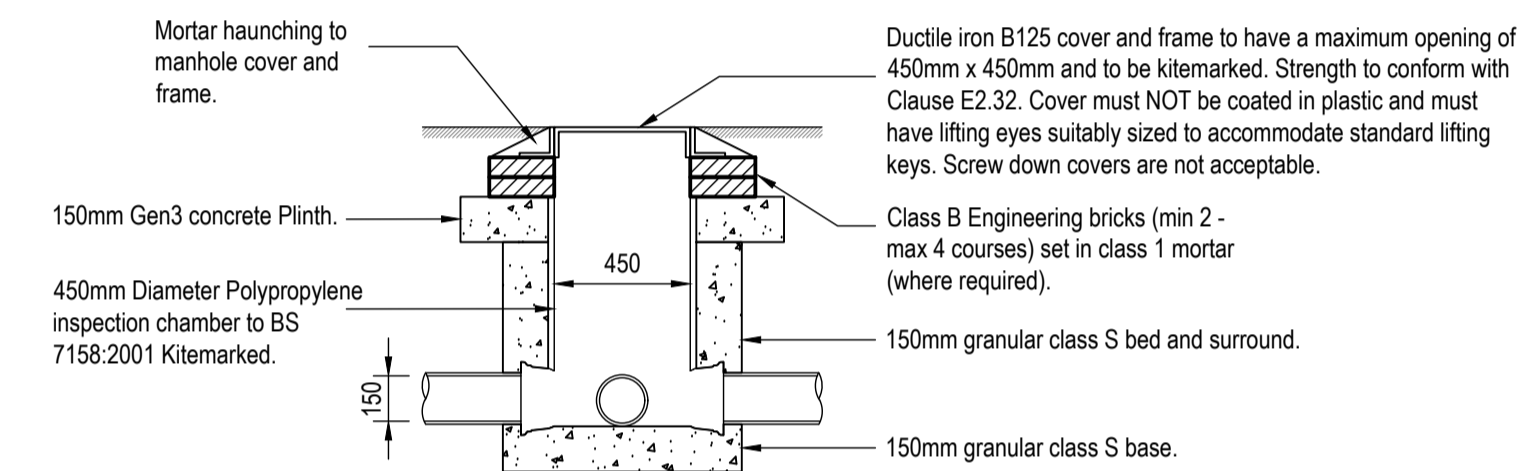

**DEMARICATION CHAMBER LOCATED IN DRIVEWAY**  
Depth from cover level to invert level of pipe chamber greater than 1200mm (maximum depth 2000mm). Maximum lateral drain diameter 150mm.

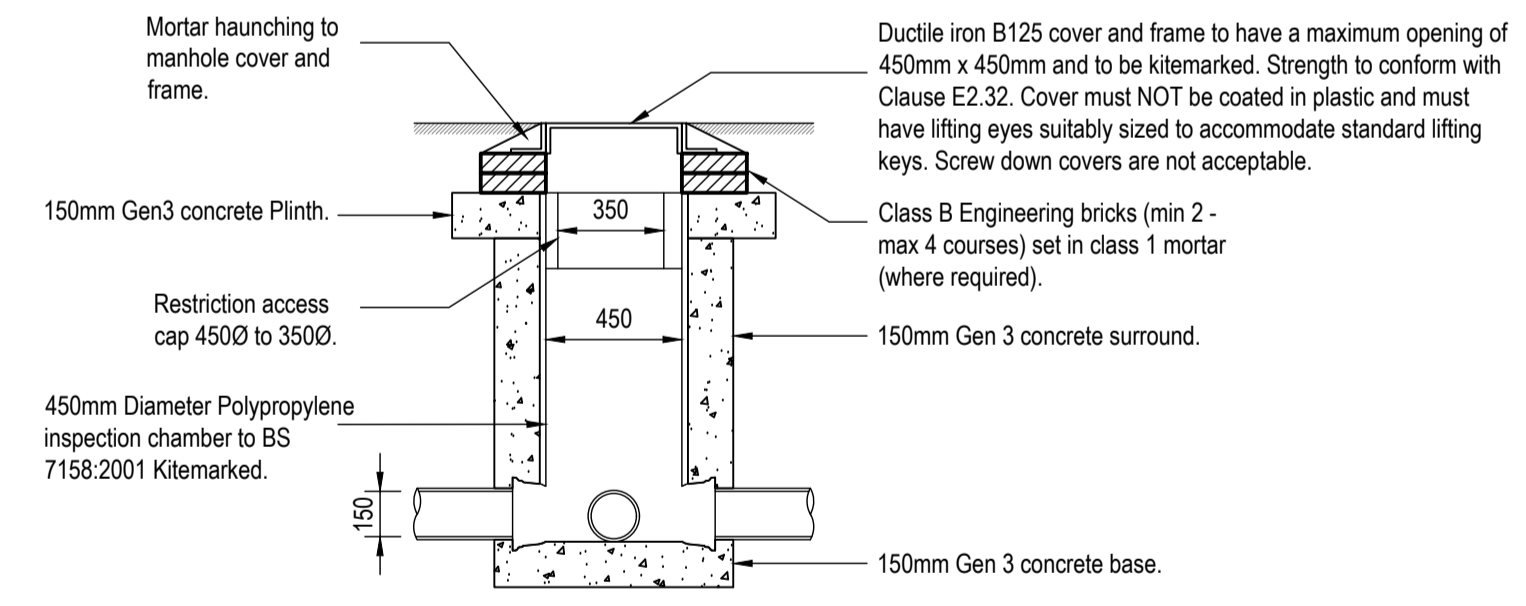

**DEMARICATION CHAMBER LOCATED IN DRIVEWAY**  
Depth from cover level to invert level of pipe chamber less than 1200mm. Maximum lateral drain diameter 150mm.

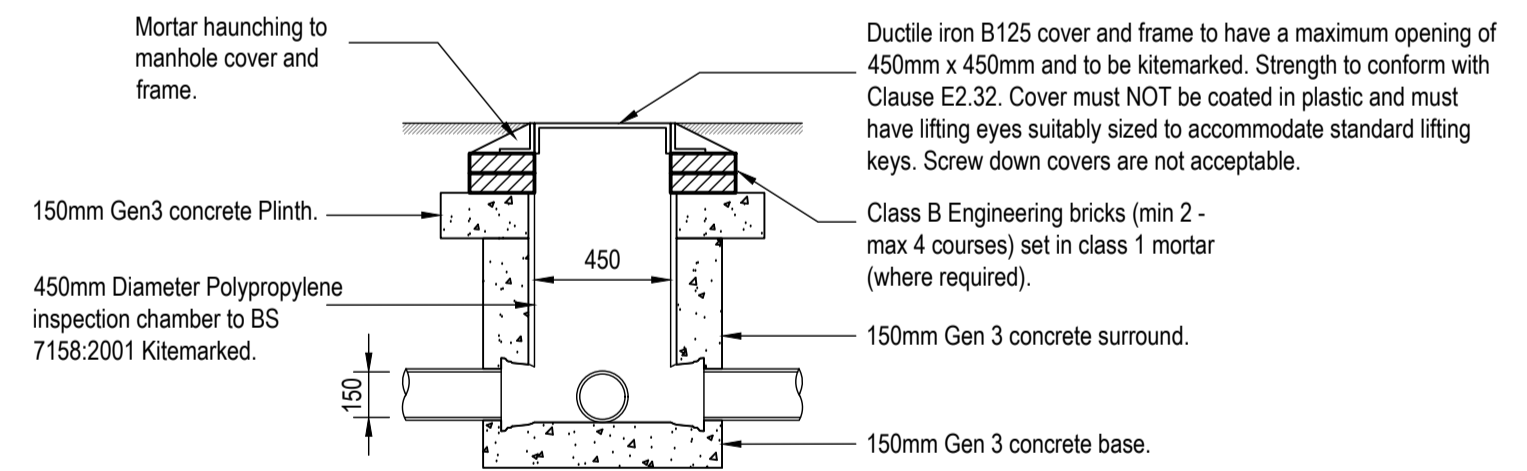

**PIPES**

Diameter (mm)	Gradient
100	Foul S.W.
150	1:150

**NOTE:**  
Vitrified clay pipes to BS EN 295 kitemarked. Unplasticised PVC pipes to BS 4660:200 & BS EN 1401-1 kitemarked. Structured Wall Unplasticised PVC pipes to WIS 4-35-01 kitemarked.

**DEMARICATION CHAMBER COVERS & FRAMES**

Surface	Class (Loading in kN)	Loading
Road	D400	Vehicle Impact
Footway & Driveway	B125	Occasional vehicle loading
Gardens	B125	Pedestrian/cyclist

**MINIMUM DEPTH OF LATERAL DRAINS**

Location	Minimum Depth (m)
Gardens	0.9
Agricultural/Open spaces	0.9
Driveways (trafficked areas)	1.2 (see detail)

**LATERAL DRAIN BEDDING DETAIL**

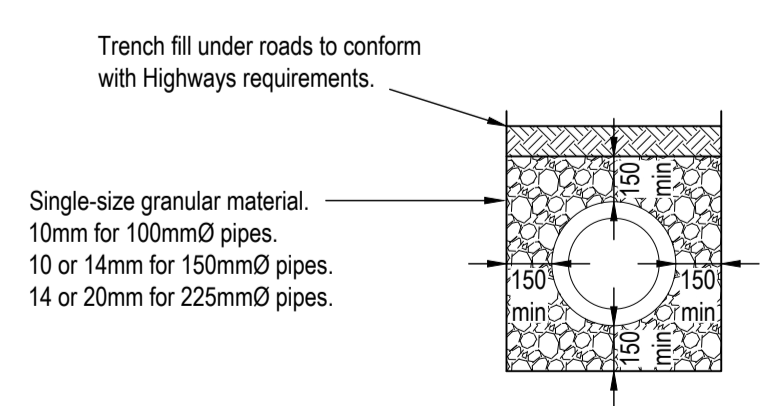

**PIPE SURROUND DETAILS**

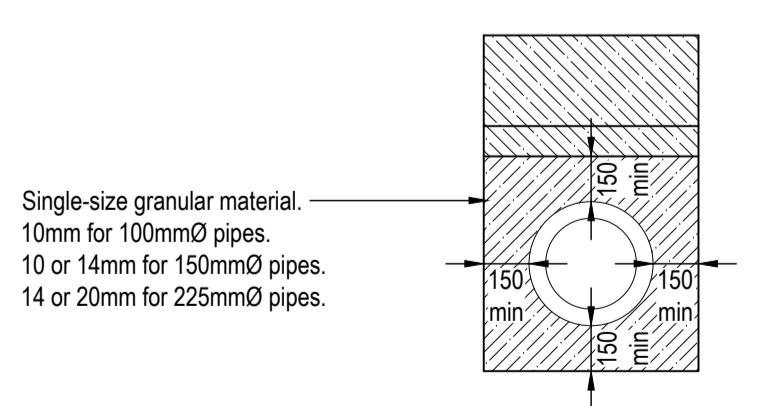

TYPICAL DETAIL THROUGH CLASS S BED AND SURROUND

Boxing/ Sheet to be removed progressively during placement of the main backfill above the pipe to prevent displacement of the granular material.

Side fill material to be placed evenly on both sides of the pipe taking care to work material under the lower quadrant of the pipe whilst ensuring the pipe is not lifted. Both sides of the trench should be filled simultaneously to avoid horizontal movement of the pipe.

Trench fill under roads to conform with Highways requirements.

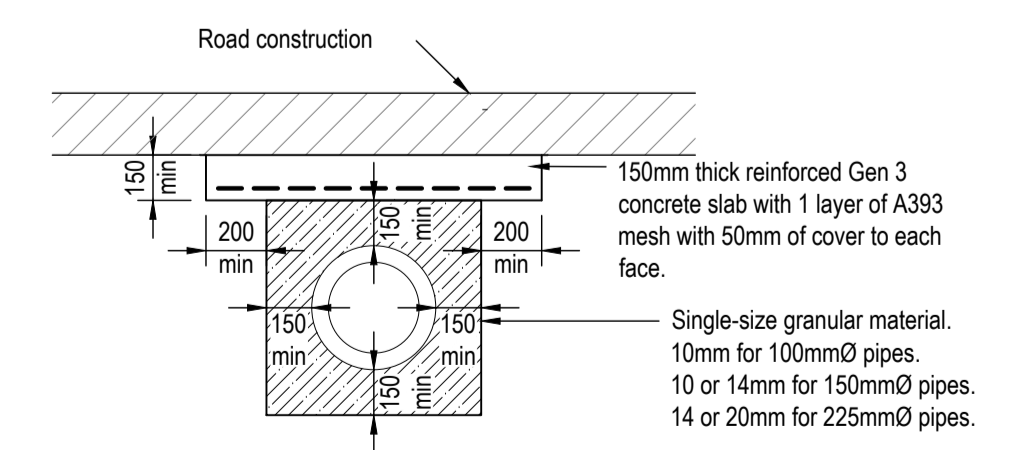

TYPICAL DETAIL THROUGH CLASS S BED AND SURROUND WITH CONCRETE SLAB PROTECTION (TO BE USED WHERE SEWER IS LESS THAN 1200mm IN DEPTH IN TRAFFICKED AREAS AND LESS 900mm IN UN-TRAFFICKED AREAS)