

Memo

To National Highways	Project name Humber Zero - Phillips 66 and VPI Developments	Project number 60712174	Subject National Highways Response 3
Date May 13 2024	Document ref DevHU0163 004 TM	Issued by Mark Romanowski	Prepared by Amelia Simmons
Checked by Mark Romanowski	Revision No. 0		

1. Background

This document represents the third step in responding to comments received from National Highways (Document Ref. DevHU0163 004 TM, dated 15th April 2024) in relation to the Humber Zero developments at Phillips 66 and VPI Immingham.

Following information provided by AECOM within Response 1 (dated 16th February 2024) National Highways provided a further response dated 7th March 2024 (Ref DevHU0163 Phillips 66 and VPI). Response 2 (dated 27th March 2024) addressed these comments and National Highways have issued their latest comments.

This response deals with outstanding comments provided within the DevHU0163 004 TM document.

A list of appendices supplied as part of this response is provided below:

- Appendix A – Traffic Flow Diagrams
- Appendix B – Modelling Outputs
- Appendix C – Modelling Geometries

Direct quotes from National Highways responses are shown in italics. Modeling input files are also included.

2. National Highways Accepted Comments

Within the latest response from National Highways, a number of elements have now been agreed upon. These are outlined below.

2.1 Junction Locations

National Highways agree with the extents of the junctions that have been assessed in relation to the distribution and impact of the Phillips 66 and VPI Immingham developments. In relation to the junctions assessed, JSJV states that:

“Considering the evidence presented, we are in agreement that junctions west of Junction 4 do not require capacity assessments.”

The approach taken is therefore deemed acceptable.

2.2 Validity of Traffic Surveys

The data received from traffic surveys at three junctions (A160/Eastfield Road, M180 Junction 5, and M180 Junction 4) was deemed acceptable when a comparison of the traffic survey data and WebTRIS data was presented:

“This notwithstanding, the traffic survey has recorded a greater number of vehicle movements than the WebTRIS data in this instance, and in the majority of comparisons. As such, we would consider the traffic data appropriate for use.”

The approach taken is therefore deemed acceptable.

2.3 Committed Developments

Several committed developments were included within the junction modelling, which JSJV deemed to be appropriate. In relation to the committed developments included, and the reasoning for the exclusion of selected committed developments, JSJV stated that:

“Considering the information presented we consider this to be appropriate.”

The approach taken is therefore deemed acceptable.

3. National Highways Outstanding Comments

3.1 National Highways Comment 1 (Availability of Queue Data)

“This notwithstanding, we do note that there is no information provided with regard to existing queues. The availability of queue data, associated with both the new surveys and the Immingham Eastern Ro-Ro Terminal [IERRT] Transport Assessment [TA], should be clarified as this is required to calibrate and validate the traffic models.”

3.2 AECOM Response Comment 1 (Availability of Queue Data)

Existing queue data for the three junctions where new traffic surveys were obtained in 2024 is presented below in **Table 1**. However, queue data could not be obtained for the IERRT TA. Therefore, it is assumed that the IERRT count data has already been deemed acceptable given the current stage of the scheme within the DCO process.

Table 1. Queue Data (2024 Traffic Counts)

Junction Name	Arm	AM Observed Queues (Hourly Average)	PM Observed Queues (Hourly Average)
Junction 1 – A160 / Eastfield Road	Eastfield Road North	3	16
	A160 West	7	4
	Eastfield Road South	5	5
	A160 East	7	8
		AM Observed Queues (15-minute peak)	PM Observed Queues (15-minute peak)
Junction 4 – M180 / A15 / A18	A15 North	7	5
	Barnetby Top	4	2
	M180 West	13	14
	A18 South	7	3
	M180 East	6	28
		AM Observed Queues (15-minute peak)	PM Observed Queues (15-minute peak)
Junction 6 – M180 / A15	A15 North	4	3
	M180 East	7	8
	A15 South	12	11
	M180 East	12	10

This queue data was compared to those derived within the modelling presented from Section 4 onwards, in order to calibrate and validate the models.

3.3 National Highways Comment 2 (Capacity Assessments)

JSJV assessed the modelling of each junction and its associated inputs and outputs. The comments queried geometries, signals, calibration and validation, and HGV proportions. The following sections of this response will address each comment in relation to its associated junction. The input files for each of the models have also been provided.

4. Junction A - A160 / Eastfield Road Junction (Signalised Junction)

4.1 AECOM Response – Geometry

In terms of geometry, and in line with comments from JSJV, the following modifications have been made:

- Eastfield Road (south) – lane length has been increased from 3.7 PCU to 60 PCU; and
- Eastfield Road (north) – lane 4/1 radius has been revised to 20m and lane 4/2 length has been increased from 11.8 PCU to 60 PCU, alongside a right-turn radius revision to 25m.

4.2 AECOM Response – Signal Phasing, Staging, Intergreens and Cycle Times

JSJV Comment:

“There is a need to confirm that the signal phasing, staging, intergreens and cycle time represent the current on-site operation”

AECOM can confirm that video footage provided by the traffic survey company was used to inform the signal phasing, staging, intergreens and cycle times at the junction. The footage provided was for the AM period only and therefore inferences were made to reflect a change in the direction of traffic flows for the PM period.

4.3 AECOM Response – Queue Validation

All base modelling queues were validated against survey data, and the lane queue in the modelled results is representative of observed conditions. This is shown in **Table 2**.

Table 2. A160 / Eastfield Road Junction Queue Validation

Junction Name	Arm	AM Observed Queues (Hourly Average)	AM Modelled Queues (Hourly Average)	PM Observed Queues (Hourly Average)	PM Modelled Queues (Hourly Average)
Junction 1 – A160 / Eastfield Road	Eastfield Road North	3	4	16	16
	A160 West	7	8	4	8
	Eastfield Road South	5	7	5	7
	A160 East	7	8	8	13

All observed and modelled queues are within 5 PCUs when compared and are therefore deemed to be within an acceptable range.

4.4 AECOM Response – Modelling Results

The junction has been modelled using LINSIG and the amended modelling results for this junction are provided in **Table 3** below. Full details of the modelling inputs and outputs, including staging diagrams and cycle timings are provided in **Appendix B**.

Table 3. Junction A - A160 / Eastfield Road Junction – Amended Model Results

Scenario	Junction Arm	AM			PM		
		DoS (%)	Average Delay (s)	Mean Max Queue	DoS (%)	Average Delay (s)	Mean Max Queue
Base 2025	A160 WB Ahead Left	41.2%	22.6	8.7	68.0%	46.4	12.7
	A160 WB Ahead Right	74.8%	29.5	8.4	71.2 %	48.8	13.6
	Eastfield Road NB	71.3%	72.7	7.2	56.8%	56.0	6.9
	A160 EB Left Ahead	53.8%	10.0	8.5	54.2%	27.0	9.1
	A160 EB Ahead Right	44.1%	26.8	7.1	48.2%	42.0	7.9
	Eastfield Road SB Left	15.1%	45.2	1.6	18.6%	31.2	2.9
	Eastfield Road SB Right Ahead	75.8%	82.7	7.0	101.0%	136.4	29.5
	Overall PRC		18.7%			-12.2%	
	Cycle time		120s			120s	
Base 2025 + Committed Development	A160 WB Ahead Left	42.4%	22.8	9.1	88.2%	63.6	19.8
	A160 WB Ahead Right	82.2%	30.2	8.7	92.6%	62.7	21.1
	Eastfield Road NB	73.5%	74.6	7.6	57.4%	56.2	7.0
	A160 EB Left Ahead	61.1%	9.2	9.2	57.9%	28.0	10.0
	A160 EB Ahead Right	44.1%	26.9	7.8	53.1 %	43.0	8.9
	Eastfield Road SB Left	15.3%	45.2	1.7	18.9%	31.2	3.0
	Eastfield Road SB Right Ahead	78.0%	85.4	7.3	101.0%	136.4	29.5
	Overall PRC		9.4%			-12.2%	
	Cycle time		120s			120s	
Base 2025 + Committed + Proposed Developments	A160 WB Ahead Left	42.6%	22.9	9.1	91.2%	70.2	21.5
	A160 WB Ahead Right	91.3%	31.0	8.5	94.6%	68.5	22.7
	Eastfield Road NB	73.5%	74.6	7.6	57.4%	56.2	7.0
	A160 EB Left Ahead	77.0%	9.9	8.6	57.7%	27.9	9.9
	A160 EB Ahead Right	48.2%	27.8	9.9	53.6%	43.0	9.0
	Eastfield Road SB Left	15.3%	45.2	1.7	20.9%	31.5	3.3
	Eastfield Road SB Right Ahead	78.0%	85.4	7.3	138.5%	624.8	133.0
	Overall PRC		-1.4%			-53.9%	
	Cycle time		120s			120s	

The results indicate that during the AM period, all lanes continue to operate stably, aside from the 'A160 WB Ahead Right' lane which is marginally constrained when the Proposed Developments' traffic is added. However, the average delay and queues remain manageable under this scenario.

In the PM period, all lanes operate stably aside from 'A160 WB Ahead Left' when the Proposed Developments' traffic is added, and 'Eastfield Road SB Right Ahead' in all scenarios. The 7.4% increase in the DoS for the 'A160 WB Ahead Left' lane is marginal, with the delay and queues remaining manageable.

The 'Eastfield Road SB Right Ahead' lane is already overloaded (101%) in the PM Base and PM Base + Committed scenarios. However, this significantly increases further once the Proposed Developments' traffic is added. This is coupled with a significant rise in delays and queuing. To mitigate against the overloaded operation of this lane, signal timings were optimised to show how the junction could operate under timing changes. This essentially increases the green time for the 'Eastfield Road SB Right Ahead' lane. The results are provided in **Table 4** below for the affected PM period.

Table 4. Junction A - A160 / Eastfield Road Junction Model Results – With Signal Timing Changes

Scenario	Junction Arm	PM		
		DoS (%)	Average Delay (s)	Mean Max Queue
Base 2025 + Committed + Proposed Developments (with Optimised Signal Timings)	A160 WB Ahead Left	96.4%	13.9	25.1
	A160 WB Ahead Right	100.4%	16.8	27.3
	Eastfield Road NB	97.1%	8.9	12.7
	A160 EB Left Ahead	61.2%	4.3	10.3
	A160 EB Ahead Right	56.3%	4.3	9.1
	Eastfield Road SB Left	16.5%	0.9	2.8
	Eastfield Road SB Right Ahead	102.3%	26.0	41.0
	Overall PRC		-13.6%	
	Cycle time		120s	

With the mitigation measure (signal timing optimisation) in place, only two lanes are marginally overloaded. When compared with the non-mitigation scenario, there is a decrease in the queue on the 'Eastfield Road SB Right Ahead' lane of 92 PCUs (decreasing from approximately 133 to 41).

In addition, it should be reiterated that the assessment is a worst-case scenario, based on the temporary peak of construction, coupled with the other committed developments at their peak of construction. Any temporary impacts would be managed through the Construction Worker Travel Plan and Construction Traffic Management Plan.

5. Junction B - A160 / Habrough Rd (Habrough Roundabout)

5.1 AECOM Response – Traffic Flows

JSJV noted that further clarification would be required on the 1 additional trip that is expected to use the junction in the AM peak:

“From a review of the traffic flow diagrams, it is noted that the junction will see 1 and 228 additional trips in the AM and PM respectively. We would request clarification on the AM figure.”

However, the traffic flows presented show 216 additional trips in the AM (212 along the A160 West and 4 along the A160 East). It is assumed that JSJV accounted for the A160 East additional traffic flow only.

5.2 AECOM Response – Geometry

Based on aerial imagery, JSJV suggested that the half-width and entry width of two arms should be revised, alongside all geometric parameters reviewed. JSJV also noted that:

“All input geometry measurements should be shown on CAD PDF for review, adhering to the guidance in the Junctions 10 manual, measurements should reflect the road markings and not the entire available road surface.”

In response to comments regarding geometry, for this junction AECOM have now used the same geometries as those used within the IERRT junction model for consistency. These were previously agreed with JSJV / National Highways. These measurements have also been double checked using Bing mapping, then inserted into a CAD plan. Any small differences in the measurements have been noted, as provided in **Table 5**. The measurements on a CAD plan are also provided in **Appendix C**.

It should be noted that according to the Junctions 10 User Guide, the precision of geometry measurements can be subjective and there is margin for value differences. The method of using an online mapping tool for taking measurements is also considered the most accurate, as OS Mastermapping, for example, does not include road markings. On this basis, it is concluded that the geometries stated will now be acceptable.

Table 5. A160 / Habrough Rd (Habrough Roundabout) Geometries

Arm	Geometry Type	IERRT Geometries	AECOM Measured Geometries
A160 East	Entry Width	9.26m	9.26m
	Approach Width	9.71m	7.79m (reduced to reflect road markings)
	Effective Flare Length	20m	20m
	Entry Radius	50.7m	50.7m
	Entry Conflict Angle	35 degrees	35 degrees
	Inscribed Circle Diameter	99.96m	99.96m
Habrough Road	Entry Width	6.91m	6.91m
	Approach Width	3.89m	3.89m
	Effective Flare Length	13.72m	13.72m
	Entry Radius	15.1m	15.1m
	Entry Conflict Angle	51 degrees	51 degrees
	Inscribed Circle Diameter	99.96m	99.96m
A160 West	Entry Width	9.43m	9.43m
	Approach Width	10.74m	7.28m (reduced to reflect road markings)
	Effective Flare Length	15m	15m
	Entry Radius	36.02m	36.02m
	Entry Conflict Angle	38 degrees	38 degrees
	Inscribed Circle Diameter	99.96m	99.96m
Ulceby Road	Entry Width	6.92m	6.92m
	Approach Width	3.91m	3.91m
	Effective Flare Length	10.26m	10.26m
	Entry Radius	32.85m	32.85m
	Entry Conflict Angle	35 degrees	35 degrees
	Inscribed Circle Diameter	99.96m	99.96m
East Halton Road	Entry Width	7.53m	7.53m
	Approach Width	3.68m	3.68m

Arm	Geometry Type	IERRT Geometries	AECOM Measured Geometries
	Effective Flare Length	12.6m	12.6m
	Entry Radius	27.16m	27.16m
	Entry Conflict Angle	38 degrees	38 degrees
	Inscribed Circle Diameter	99.96m	99.96m

5.3 AECOM Response – Queue Validation

The base traffic flows for this junction were obtained from the IERRT TA. However, queue data from this TA is not available. Given that these flows were previously agreed with JSJV / National Highways it can be concluded that the flows used when modelling the junction are also acceptable.

Further, in terms of calibration, the slope and intercept have been entered directly to replicate the values used within the IERRT Junctions 10 modelling and these have been previously accepted so are therefore deemed suitable.

5.4 AECOM Response – HGV Proportions

The baseline traffic flows at this junction were obtained from the IERRT TA. Therefore, the same HGV proportion inputs were used within the modelling for this TA.

5.5 Modelling Results

The junction has been modelled using Junctions 10 and the amended modelling results for this junction are provided in **Table 6** below.

Table 6. Junction B - A160 / Habrough Rd (Habrough Roundabout) Model Results

Scenario	Junction Arm	AM			PM		
		Queue (PCU)	Delay (s)	RFC	Queue (PCU)	Delay (s)	RFC
Base 2025	A160 East	0.4	2.56	0.19	0.9	2.70	0.41
	Habrough Rd	0.3	2.88	0.21	0.1	3.34	0.11
	A160 West	1.0	2.55	0.46	0.4	2.24	0.23
	Ulceby Rd	0.3	5.74	0.20	0.1	3.23	0.07
	East Halton Rd	0.4	4.78	0.22	0.3	2.78	0.23
Base 2025 + Committed Development	A160 East	0.4	2.60	0.20	1.3	3.22	0.50
	Habrough Rd	0.3	2.96	0.22	0.2	4.20	0.13
	A160 West	1.5	3.07	0.55	0.5	2.33	0.25
	Ulceby Rd	0.5	8.14	0.26	0.1	3.35	0.08
	East Halton Rd	0.5	6.40	0.28	0.3	2.89	0.24
Base 2025 + Committed +	A160 East	0.4	2.60	0.20	1.8	3.90	0.59
	Habrough Rd	0.3	2.96	0.22	0.2	5.50	0.17

Proposed Developments	A160 West	2.0	3.71	0.63	0.5	2.34	0.25
	Ulceby Rd	0.7	12.39	0.35	0.1	3.37	0.08
	East Halton Rd	0.7	8.83	0.35	0.3	2.90	0.24

The results indicate that the junction is predicted to operate satisfactorily in all scenarios, even with the addition of committed traffic and Proposed Developments' construction traffic.

6. Junction C - A160 / A180 Junction

6.1 AECOM Response – Geometry

Based on aerial imagery, JSJV suggested that the half-width and entry width of two arms, alongside the inscribed circle diameters for all arms, are reviewed. JSJV also noted that:

“All input geometry measurements should be shown on CAD PDF for review, adhering to the guidance in the Junctions 10 manual, measurements should reflect the road markings and not the entire available road surface.”

As with Junction B, AECOM have now used the same geometries as those used within the IERRT junction model for consistency. These were previously agreed with JSJV / National Highways. These measurements have also been double checked using Bing mapping, then inserted into a CAD plan. Any small differences in the measurements have been noted, as provided in **Table 7**. The measurements on a CAD plan are also provided in **Appendix C**.

It should be noted that according to the Junctions 10 User Guide, the precision of geometry measurements can be subjective and there is margin for value differences. The method of using an online mapping tool for taking measurements is also considered the most accurate, as OS Mastermapping, for example, does not include road markings. On this basis, it is concluded that the geometries stated will now be acceptable.

Table 7. A160 / A180 Geometries

Arm	Geometry Type	IERRT Geometries	Proposed Developments' Geometries
A180 East	Entry Width	8.23m	5.04m (reduced to reflect road markings)
	Approach Width	7.96m	3.96m (reduced to reflect road markings)
	Effective Flare Length	5m	5m
	Entry Radius	25.92m	25.92m
	Entry Conflict Angle	44 degrees	44 degrees
	Inscribed Circle Diameter	102m	102m
A180 West	Entry Width	8.19m	8.19m
	Approach Width	10.41m	4.61m (reduced to reflect road markings)
	Effective Flare Length	30m	30m
	Entry Radius	75.35m	75.35m
	Entry Conflict Angle	30 degrees	30 degrees

Arm	Geometry Type	IERRT Geometries	Proposed Developments' Geometries
A160	Inscribed Circle Diameter	102m	102m
	Entry Width	8.39m	8.39m
	Approach Width	7.7m	7.7m
	Effective Flare Length	5m	5m
	Entry Radius	37.93m	37.93m
	Entry Conflict Angle	36 degrees	36 degrees
	Inscribed Circle Diameter	102m	102m

The bypass for the A160 West was also set at 100% in the IERRT modelling, and this has been replicated.

6.2 AECOM Response – Queue Validation

The base traffic flows for this junction were obtained from the IERRT TA. However, queue data from this TA is not available. Given that these flows were previously agreed with JSJV / National Highways it can be concluded that the flows used when modelling the junction are also acceptable.

Further, in terms of calibration, the slope and intercept have been entered directly to replicate the values used within the IERRT Junctions 10 modelling and these have been previously accepted so are therefore deemed suitable.

6.3 AECOM Response – HGV Proportions

The baseline traffic flows at this junction were obtained from the IERRT TA. Therefore, the same HGV proportion inputs were used within the modelling for this TA.

6.4 Modelling Results

The junction has been modelled using Junctions 10 and the amended modelling results for this junction are provided in **Table 8** below.

Table 8. Junction C - A160 / A180 Junction Model Results

Scenario	Junction Arm	AM			PM		
		Queue (PCI)	Delay (s)	RFC	Queue (PCI)	Delay (s)	RFC
Base 2025	A160	0.4	1.72	0.26	0.8	2.43	0.40
	A180 East	0.9	6.64	0.48	0.2	4.91	0.17
	A180 West	0.0	0.00	0.00	0.0	0.00	0.00
Base 2025 + Committed Development	A160	0.4	1.74	0.26	1.2	2.95	0.49
	A180 East	1.1	7.35	0.52	0.3	6.30	0.21
	A180 West	0.0	0.00	0.00	0.0	0.00	0.00
Base 2025 + Committed + Proposed Developments	A160	0.4	1.74	0.26	1.6	3.43	0.56
	A180 East	1.2	7.44	0.54	0.5	8.06	0.30
	A180 West	0.0	0.00	0.00	0.0	0.00	0.00

The results indicate that the junction is predicted to operate satisfactorily in all scenarios, even with the addition of committed traffic and Proposed Developments' construction traffic.

7. Junction D - M180 Junction 5

7.1 AECOM Response – Geometry

Based on aerial imagery, JSJV suggested that the half-width and entry arms for two lanes, as well as all inscribed circle diameters, are reviewed. JSJV also noted that:

“All input geometry measurements should be shown on CAD PDF for review, adhering to the guidance in the Junctions 10 manual, measurements should reflect the road markings and not the entire available road surface.”

In response to comments regarding geometry, AECOM have used AutoCAD with Bing mapping to measure each element of the geometry inputs and amended these accordingly in Junctions 10. The geometries are presented in **Appendix C**. It should be noted that according to the Junctions 10 User Guide, the precision of geometry measurements can be slightly subjective and there is therefore margin for value differences.

7.2 AECOM Response – Queue Validation

Calibration and validation have been undertaken in association with the submitted Junctions 10 outputs.

In terms of calibration, this was undertaken using the 'direct' intercept adjustment, to ensure that the model queues align with the highest of the 15-minute average queues observed on each arm.

The observed queue data is presented below in **Table 9**.

Table 9. A160 / A180 Junction Queue Validation

Junction Name	Arm	AM Observed Queues	AM Modelled Queues	PM Observed Queues	PM Modelled Queues
Junction 4 – M180 / A15 / A18	A15 North	7	7	5	5
	Barnetby Top	4	4	2	2
	M180 West	13	12	14	14
	A18 South	7	7	3	3
	M180 East	6	1	28	27

The model was calibrated, and all observed and modelled queues are within 5 PCUs when compared and are therefore deemed to be within an acceptable range.

7.3 AECOM Response – HGV Proportions

The traffic survey data has now been used to calculate the proportion of HGVs that utilise the junction in the AM and PM peaks respectively. This has been reflected in the modelling.

7.4 Modelling Results

Modelling results for this junction are provided in **Table 10** below.

Table 10. Junction D – M180 Junction 5 Model Results

Scenario	Junction Arm	AM			PM		
		Queue (PCI)	Delay (s)	RFC	Queue (PCI)	Delay (s)	RFC
Base 2025	M180 East	1.3	7.82	0.54	27.2	113.85	1.04
	A18	6.9	28.19	0.88	2.6	13.57	0.72
	M180 West	11.5	46.71	0.94	14.4	52.27	0.96
	Barnetby Top	4.1	72.78	0.84	1.6	38.46	0.61
	A15	7.3	17.32	0.88	4.8	11.48	0.82
Base 2025 + Committed Development	M180 East	1.5	9.07	0.57	49.2	184.47	1.12
	A18	20.0	74.55	1.00	2.7	13.96	0.73
	M180 West	38.6	134.11	1.07	16.0	57.90	0.97
	Barnetby Top	15.3	215.30	1.10	1.5	36.68	0.59
	A15	14.3	31.95	0.94	5.0	12.00	0.83
Base 2025 + Committed + Proposed Development	M180 East	1.4	8.76	0.57	4.1	16.30	0.80
	A18	17.6	66.77	0.98	8.2	43.52	0.91
	M180 West	39.3	136.09	1.07	3.3	18.30	0.76
	Barnetby Top	15.4	216.11	1.10	0.6	14.04	0.35
	A15	28.7	57.72	1.00	2.3	5.29	0.68

The results indicate that during the AM period, with the addition of the Proposed Developments', one arm is predicted to operate close to capacity (A180), one at capacity (A15), and two over capacity (M180 West and Barnetby Top).

However, when comparing to the baseline, two of these arms are already operating close to capacity (A18 and M180 West). Further, with the addition of the committed developments, the modelling results show that the same number of arms will operate close to, or over capacity, as when the Proposed Developments' traffic is added.

In the AM, when adding the Proposed Developments' traffic, only one arm (A15) will have significantly higher queues when comparing to the baseline plus committed modelling results. All other arms have a deviation of between 0.1 and 2.4 PCUs.

The results indicate that during the PM period, with the addition of the Proposed Developments', one arm (A18) is predicted to operate close to capacity. All other arms operate below capacity.

It should be reiterated that the assessment is a worst-case scenario, based on the temporary peak of construction, coupled with the other committed developments at their peak of construction. Any temporary impacts would be managed through the Construction Worker Travel Plan and Construction Traffic Management Plan.

Further, given that this junction is located approximately 13km (linear) from the site, it is likely that some vehicles leaving towards the end of the peak hour will not reach the junction in the same hour, therefore have no impacts in that period.

8. Junction E – A160 / Humber Road / Manby Road (Manby Roundabout)

8.1 AECOM Response – Geometry

Based on aerial imagery, JSJV suggested that the inscribed circle diameters, alongside all geometric parameters reviewed. JSJV also noted that:

“All input geometry measurements should be shown on CAD PDF for review, adhering to the guidance in the Junctions 10 manual, measurements should reflect the road markings and not the entire available road surface.”

In response to comments regarding geometry, for this junction AECOM have now used the same geometries as those used within the IERRT junction model for consistency. These were previously agreed with JSJV / National Highways. These measurements have also been double checked using Bing mapping, then inserted into a CAD plan. Any small differences in the measurements have been noted, as provided in **Table 11**. The measurements on a CAD plan are also provided in **Appendix C**.

It should be noted that according to the Junctions 10 User Guide, the precision of geometry measurements can be subjective and there is margin for value differences. The method of using an online mapping tool for taking measurements is also considered the most accurate, as OS Mastermapping, for example, does not include road markings. On this basis, it is concluded that the geometries stated will now be acceptable.

Table 11. A160 / Humber Road / Manby Road (Manby Roundabout) Geometries

Arm	Geometry Type	IERRT Geometries	Proposed Developments' Geometries
Humber Road	Entry Width	7.85m	7.85m
	Approach Width	7.01m	7.01m
	Effective Flare Length	22.3m	22.3m
	Entry Radius	35.01m	35.01m
	Entry Conflict Angle	36 degrees	36 degrees
	Inscribed Circle Diameter	85.62m	85.62m
A1173	Entry Width	8.73m	8.73m
	Approach Width	8.05m	7.11m (reduced to reflect road markings)
	Effective Flare Length	4.4m	4.4m
	Entry Radius	57.25m	57.25m
	Entry Conflict Angle	30 degrees	30 degrees
	Inscribed Circle Diameter	85.62m	85.62m
Port Services Access	Entry Width	8.16m	8.16m
	Approach Width	2.98m	2.98m
	Effective Flare Length	4.63m	4.63m
	Entry Radius	17.20m	17.20m
	Entry Conflict Angle	33 degrees	33 degrees
	Inscribed Circle Diameter	85.62m	85.62m
A160 West	Entry Width	5.61m	8.73m (increased to reflect road markings)

Arm	Geometry Type	IERRT Geometries	Proposed Developments' Geometries
Conco Access	Approach Width	7.07m	6.38m (reduced to reflect road markings)
	Effective Flare Length	1.6m	1.6m
	Entry Radius	20.98m	20.98m
	Entry Conflict Angle	41 degrees	41 degrees
	Inscribed Circle Diameter	85.62m	85.62m
	Entry Width	9.72m	8.15m (reduced to reflect road markings)
	Approach Width	7.83m	7.83m
	Effective Flare Length	15.0m	15.0m
	Entry Radius	9.69m	9.69m
	Entry Conflict Angle	52 degrees	52 degrees
Inscribed Circle Diameter	85.62m	85.62m	

8.2 AECOM Response – Queue Validation

The base traffic flows for this junction were obtained from the IERRT TA. However, queue data from this TA is not available. . Given that these flows were previously agreed with JSJV / National Highways it can be concluded that the flows used when modelling the junction are also acceptable.

Further, in terms of calibration, the slope and intercept have been entered directly to replicate the values used within the IERRT Junctions 10 modelling and these have been previously accepted so are therefore deemed suitable.

8.3 AECOM Response – HGV Proportions

The baseline traffic flows at this junction were obtained from the IERRT TA. Therefore, the same HGV proportion inputs were used within the modelling for this TA.

8.4 Modelling Results

The junction has been modelled using Junctions 10 and the amended modelling results for this junction are provided in **Table 12** below.

Table 12. Junction E - A160 / Humber Road / Manby Road (Manby Roundabout) Model Results

Scenario	Junction Arm	AM			PM		
		Queue (PCU)	Delay (s)	RFC	Queue (PCU)	Delay (s)	RFC
Base 2025	Humber Road	0.4	2.92	0.17	0.7	3.00	0.34
	Manby Road	0.4	1.96	0.22	0.2	1.95	0.14
	Phillips 66	0.0	0.00	0.00	0.0	4.48	0.01
	A160 West	0.5	2.85	0.27	0.4	2.59	0.21
	Conoco Access	0.0	1.71	0.00	0.0	0.00	0.00
Base 2025 +	Humber Road	0.4	2.88	0.18	1.0	3.38	0.42

Committed Development	Manby Road	0.5	2.11	0.27	0.2	2.12	0.15
	Phillips 66	0.0	0.00	0.00	0.0	4.93	0.01
	A160 West	0.6	3.26	0.32	0.5	2.83	0.24
	Conoco Access	0.0	1.89	0.00	0.0	0.00	0.00
Base 2025 + Committed + Proposed Developments	Humber Road	0.4	2.97	0.18	1.0	3.47	0.42
	Manby Road	0.5	2.11	0.27	0.2	2.14	0.16
	Phillips 66	0.0	0.00	0.00	0.0	4.98	0.01
	A160 West	0.7	3.33	0.33	0.5	2.82	0.25
	Conoco Access	0.0	1.94	0.00	0.0	0.00	0.00

The results indicate that the junction is predicted to operate satisfactorily in all scenarios, even with the addition of committed traffic and Proposed Developments' construction traffic.

9. Junction F - M180 Junction 4

9.1 AECOM Response – Geometry

Based on aerial imagery, JSJV suggested that the half-width and entry width of two arms, alongside all geometric parameters including inscribed diameters, be reviewed. JSJV also noted that:

“All input geometry measurements should be shown on CAD PDF for review, adhering to the guidance in the Junctions 10 manual, measurements should reflect the road markings and not the entire available road surface.”

In response to comments regarding geometry, AECOM have used AutoCAD, with Bing mapping to measure each element of the geometry inputs and amended these accordingly in Junctions 10. The geometries are presented in **Appendix C**. It should be noted that according to the Junctions 10 User Guide, the precision of geometry measurements can be slightly subjective and there is therefore margin for value differences.

9.2 AECOM Response – Queue Validation

Calibration and validation have been undertaken in association with the submitted Junctions 10 outputs.

In terms of calibration, this was undertaken using the 'direct' intercept adjustment, to ensure that the model queues align with the highest of the 15-minute average queues observed on each arm.

The observed queue data is presented below in **Table 13**.

Table 13. A160 / A180 Junction Queue Validation

Junction Name	Arm	AM Observed Queues	AM Modelled Queues	PM Observed Queues	PM Modelled Queues
Junction 6 – M180 / A15	A15 North	4	4	3	2
	M180 East	7	7	8	14
	A15 South	12	8	11	12
	M180 East	12	2	10	14

The model was calibrated, and all observed and modelled queues (aside from the M180 East in the AM) are within 5 PCUs when compared and are therefore deemed to be within an acceptable range.

Given that the observed queue data is taken from one day only, and the fact that the rest of the modelled queues are representative, the deviations in the M180 East arm are deemed acceptable.

9.3 AECOM Response – HGV Proportions

The traffic survey data has now been used to calculate the proportion of HGVs that utilise the junction in the AM and PM peaks respectively. This has been reflected in the modelling.

9.4 Modelling Results

Modelling results for this junction are provided in **Table 14** below.

Table 14. Junction F - M180 Junction 4 Model Results

Scenario	Junction Arm	AM			PM		
		Queue (PCU)	Delay (s)	RFC	Queue (PCU)	Delay (s)	RFC
Base 2025	M180 East	7.2	23.29	0.87	14.4	42.72	0.95
	A15 South	8.0	32.43	0.89	12.0	50.34	0.94
	M180 West	1.8	12.56	0.61	14.2	77.11	0.98
	A15 North	4.1	10.33	0.79	2.1	6.33	0.67
Base 2025 + Committed Development	M180 East	6.8	22.06	0.87	118.6	242.49	1.16
	A15 South	37.4	112.73	1.04	24.0	92.69	1.01
	M180 West	3.1	22.66	0.74	25.0	130.62	1.05
	A15 North	20.9	47.42	0.98	2.3	6.76	0.69
Base 2025 + Committed + Proposed Developments	M180 East	6.6	21.37	0.86	142.7	300.61	1.20
	A15 South	45.2	130.61	1.06	22.9	89.34	1.00
	M180 West	3.4	24.40	0.76	24.4	127.96	1.04
	A15 North	29.6	63.45	1.00	2.3	6.80	0.69

The results indicate that during the AM peak, with the addition of the Proposed Developments', one arm is predicted to operate close to capacity (M180 East), one will operate at capacity (A15 North) and one arm above capacity (A15 South).

However, during the base year, the M180 East and A15 South are already operating close to capacity, and when the committed developments are added, the differences in capacity are marginal (between 0.1 and 0.2) compared to the Proposed Development scenario. Therefore, the Proposed Development is adding no significant detriment to the operation of the junction. Further, the M180 West is expected to operate below capacity in all AM scenarios.

In terms of queues during the AM peak, the A15 South and A15 North have high queues in the baseline plus committed development scenario, and this continues when the Proposed Development traffic is added. The queues rise by 7.8 PCUs and 8.7 PCUs respectively. However, queues rise exponentially as the RFC rises above 1. The M180 East and M180 West queues will remain manageable.

The results indicate that during the PM peak, with the addition of the Proposed Development's, one arm is predicted to operate at capacity (A15 South) and two arms above capacity (M180 East and M180 West).

However, when comparing to the base year, the same three arms will operate close to capacity. Further, with the addition of the committed developments, all of these arms will operate above capacity. Therefore, the Proposed Developments are adding no significant detriment to the operation of the junction. Further, the A15 North is expected to operate below capacity in all PM scenarios.

In terms of queues during the PM peak, the M180 East, A15 South and M180 West all have high queues. However, when considering the level of queues in the baseline plus committed modelling results, coupled with the fact that once the RFC exceeds 1, the Proposed Developments add no further detriment. The A15 North queues will remain manageable.

In addition, it should be reiterated that the assessment is a worst-case scenario, based on the temporary peak of construction, coupled with the other committed developments at their peak of construction. Any temporary impacts would be managed through the Construction Worker Travel Plan and Construction Traffic Management Plan.

Further, given that this junction is located approximately 24km (linear) from the site, it is likely that some vehicles leaving between the middle and end of the peak hour will not reach the junction in the same hour, therefore have no impacts in that period.

10. Summary

AECOM have responded to comments received by JSJV on behalf of National Highways in relation to the Humber Zero developments at Phillips 66 and VPI Immingham. The review highlighted that the junction capacity assessments should be revised in accordance with the comments set out in the Technical Memorandum. These can be summarised as:

- Utilising existing queue data to validate and calibrate traffic models;
- Reviewing junction modelling geometries, and presenting these on AutoCAD drawings;
- Confirming signal phasing, staging, intergreens and cycle times represent the current on-site operation;
- Ensuring the HGV Percentages reflect observed proportions on Junctions 10; and
- Calibrating using the direct intercept adjustment to ensure that the model queues align with the highest 15-minute average queues on Junctions 10.

It is deemed that the information provided addresses all comments provided on behalf of National Highways and therefore modelling inputs and results can now be agreed, with the holding recommendation also removed as soon as possible.

Appendix A Traffic Flow Diagrams

Network Peak
 07:00-09:00 AM Peak
 16:00-17:00 PM Peak

2025 Baseline Traffic Flows

Produced by AS
 Checked by
 Approved by

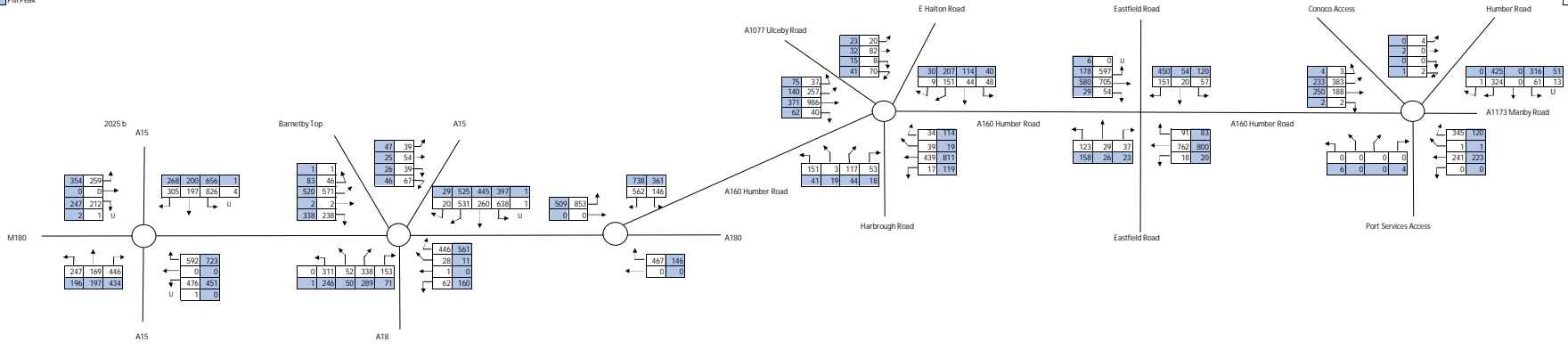

AM
 1.0443
 PM
 1.0434

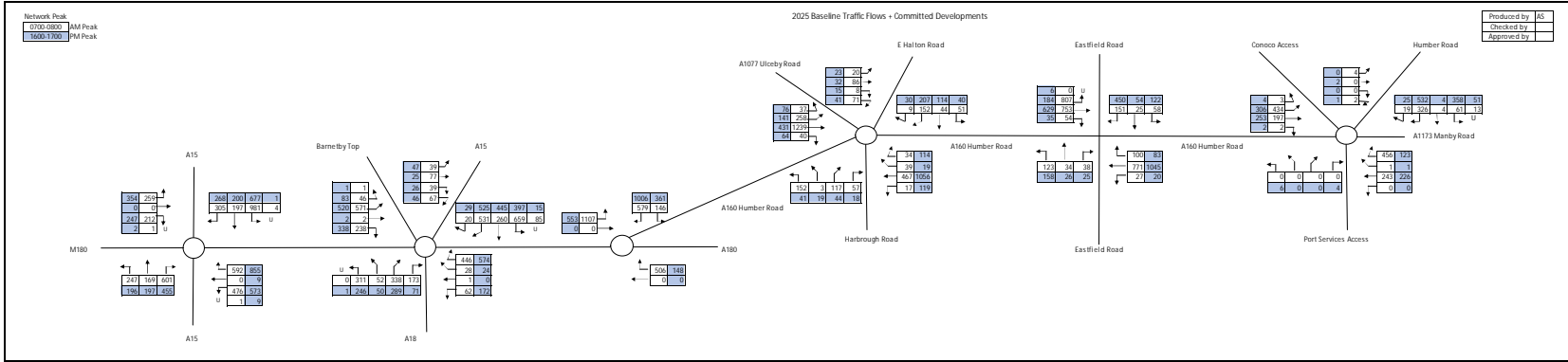

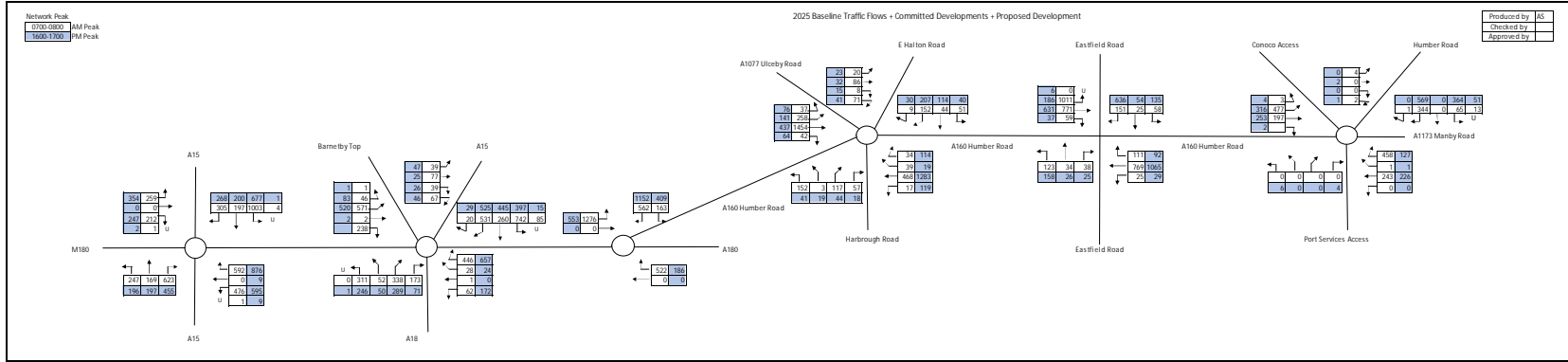

Appendix B Modelling Outputs

Full Input Data And Results
Full Input Data And Results

User and Project Details

Project:	Humber Zero
Title:	Junction Modelling
Location:	Immingham
File name:	J1 A160_EastfieldRd.lsg3x
Company:	AECOM

Network Layout Diagram

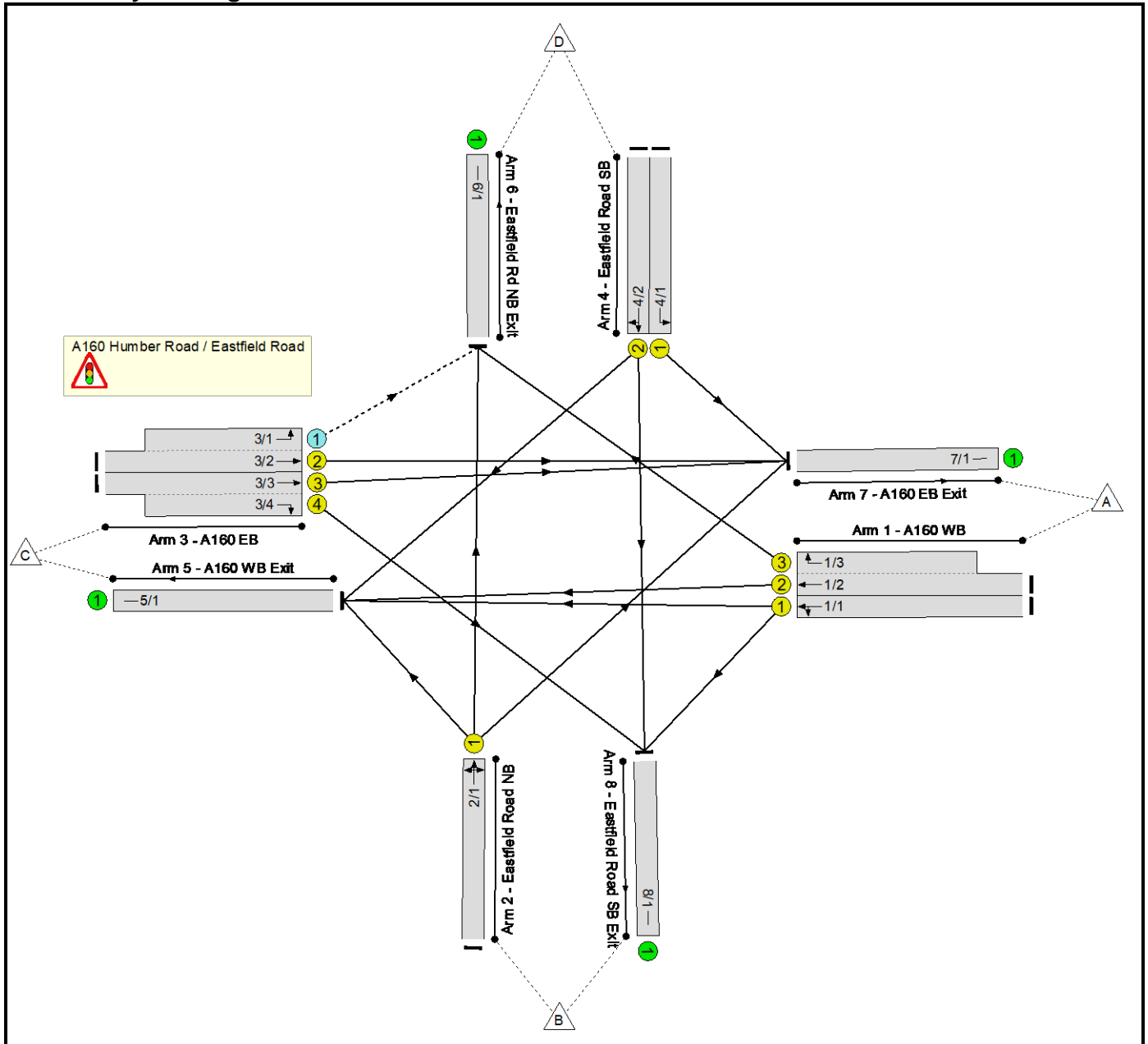

Phase Diagram

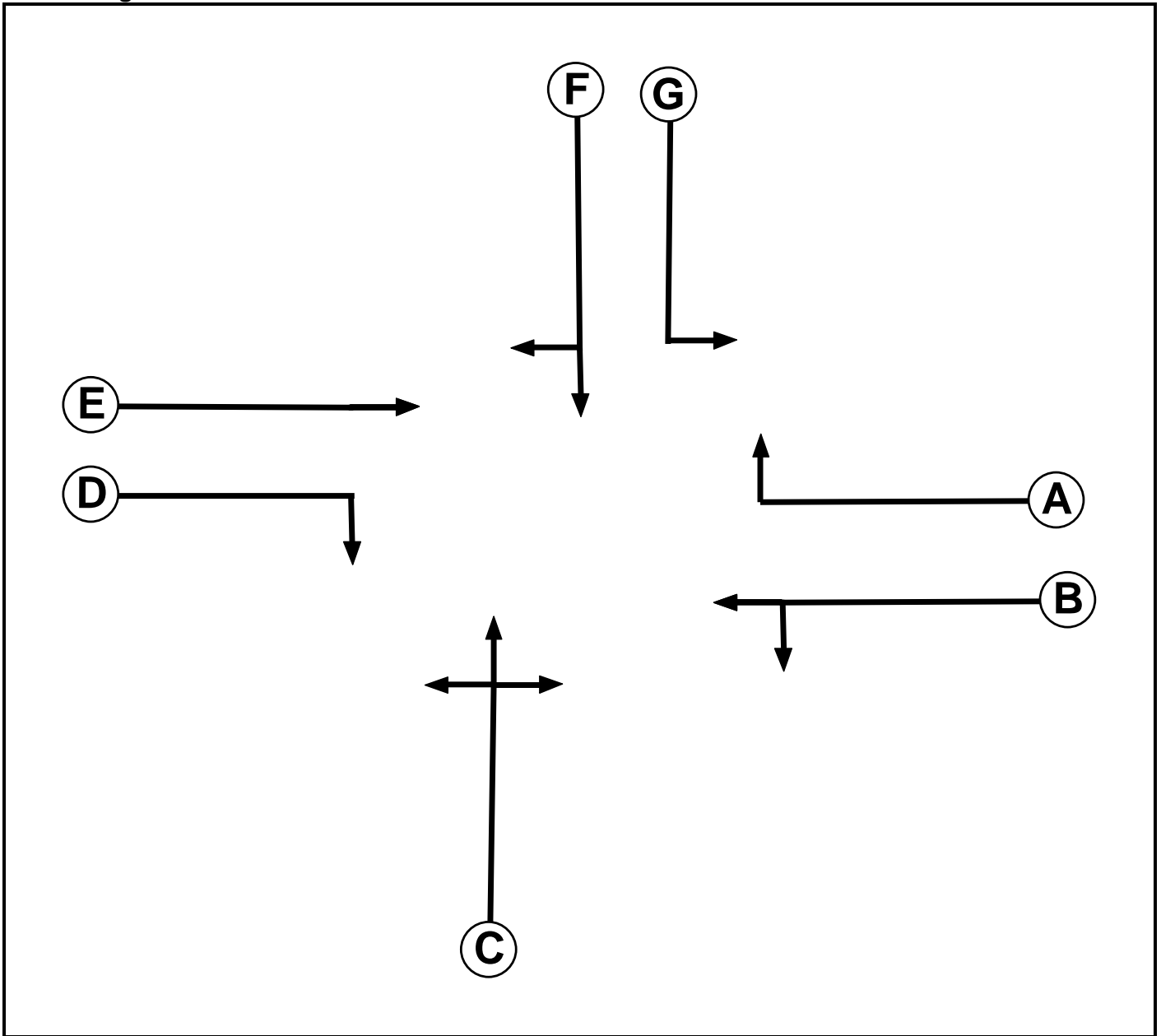

Phase Input Data

Phase Name	Phase Type	Assoc. Phase	Street Min	Cont Min
A	Traffic		7	7
B	Traffic		7	7
C	Traffic		7	7
D	Traffic		7	7
E	Traffic		7	7
F	Traffic		7	7
G	Traffic		7	7

Full Input Data And Results

Phase Intergrens Matrix

		Starting Phase						
		A	B	C	D	E	F	G
Terminating Phase	A	-	-	5	-	8	6	-
	B	-	-	8	5	-	8	-
	C	5	6	-	6	7	7	9
	D	-	7	5	-	-	6	-
	E	5	-	5	-	-	5	8
	F	5	5	7	5	5	-	-
	G	-	-	9	-	5	-	-

Phases in Stage

Stage No.	Phases in Stage
1	A D G
2	B E
3	C
4	F G

Stage Diagram

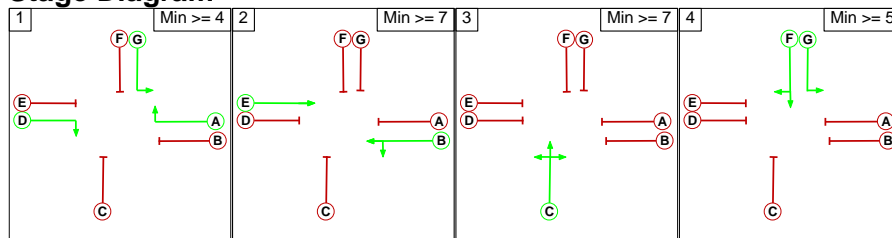

Phase Delays

Term. Stage	Start Stage	Phase	Type	Value	Cont value
There are no Phase Delays defined					

Prohibited Stage Change

		To Stage			
		1	2	3	4
From Stage	1	-	8	9	6
	2	8	-	8	8
	3	9	7	-	9
	4	5	5	9	-

Full Input Data And Results

Give-Way Lane Input Data

Junction: A160 Humber Road / Eastfield Road											
Lane	Movement	Max Flow when Giving Way (PCU/Hr)	Min Flow when Giving Way (PCU/Hr)	Opposing Lane	Opp. Lane Coeff.	Opp. Mvmnts.	Right Turn Storage (PCU)	Non-Blocking Storage (PCU)	RTF	Right Turn Move up (s)	Max Turns in Intergreen (PCU)
3/1 (A160 EB)	6/1 (Left)	1439	0	2/1	1.09	To 6/1 (Ahead)	-	-	-	-	-
				1/3	1.09	All	-	-	-	-	-

Full Input Data And Results

Lane Input Data

Junction: A160 Humber Road / Eastfield Road												
Lane	Lane Type	Phases	Start Disp.	End Disp.	Physical Length (PCU)	Sat Flow Type	Def User Saturation Flow (PCU/Hr)	Lane Width (m)	Gradient	Nearside Lane	Turns	Turning Radius (m)
1/1 (A160 WB)	U	B	2	3	129.0	Geom	-	3.51	0.00	Y	Arm 5 Ahead	Inf
											Arm 8 Left	23.56
1/2 (A160 WB)	U	B	2	3	129.0	Geom	-	3.51	0.00	Y	Arm 5 Ahead	Inf
1/3 (A160 WB)	U	A	2	3	20.0	Geom	-	3.40	0.00	Y	Arm 6 Right	20.90
2/1 (Eastfield Road NB)	U	C	2	3	60.0	Geom	-	4.50	0.00	Y	Arm 5 Left	33.50
											Arm 6 Ahead	Inf
											Arm 7 Right	32.95
											Arm 6 Left	27.80
3/1 (A160 EB)	O		2	3	17.6	Geom	-	3.30	0.00	N	Arm 6 Left	27.80
3/2 (A160 EB)	U	E	2	3	77.2	Geom	-	3.41	0.00	Y	Arm 7 Ahead	Inf
3/3 (A160 EB)	U	E	2	3	77.2	Geom	-	3.35	0.00	Y	Arm 7 Ahead	Inf
3/4 (A160 EB)	U	D	2	3	25.7	Geom	-	3.42	0.00	Y	Arm 8 Right	23.00
4/1 (Eastfield Road SB)	U	G	2	3	11.7	Geom	-	4.20	0.00	Y	Arm 7 Left	20.00
4/2 (Eastfield Road SB)	U	F	2	3	60.0	Geom	-	4.20	0.00	Y	Arm 5 Right	25.00
											Arm 8 Ahead	Inf
5/1 (A160 WB Exit)	U		2	3	60.0	Inf	-	-	-	-	-	-
6/1 (Eastfield Rd NB Exit)	U		2	3	60.0	Inf	-	-	-	-	-	-
7/1 (A160 EB Exit)	U		2	3	60.0	Inf	-	-	-	-	-	-
8/1 (Eastfield Road SB Exit)	U		2	3	60.0	Inf	-	-	-	-	-	-

Full Input Data And Results

Traffic Flow Groups

Flow Group	Start Time	End Time	Duration	Formula
1: 'AM 2025 Base'	07:00	08:00	01:00	
2: 'PM 2025 Base'	16:00	17:00	01:00	
3: 'AM 2025 Base + Committed'	07:00	08:00	01:00	
4: 'PM 2025 Base + Committed'	16:00	17:00	01:00	
5: 'AM 2025 Base + Committed + Proposed'	07:00	08:00	01:00	
6: 'PM 2025 Base + Committed + Proposed'	16:00	17:00	01:00	

Scenario 1: 'AM 2025 Base' (FG1: 'AM 2025 Base', Plan 1: 'Network Control Plan 1')

Traffic Flows, Desired

Desired Flow :

Origin	Destination					
	A	B	C	D	Tot.	
A	0	18	762	91	871	
B	37	0	123	29	189	
C	705	54	0	597	1356	
D	57	20	151	0	228	
Tot.	799	92	1036	717	2644	

Traffic Lane Flows

Lane	Scenario 1: AM 2025 Base
Junction: A160 Humber Road / Eastfield Road	
1/1	397
1/2 (with short)	474(In) 383(Out)
1/3 (short)	91
2/1	189
3/1 (short)	597
3/2 (with short)	972(In) 375(Out)
3/3 (with short)	384(In) 330(Out)
3/4 (short)	54
4/1	57
4/2	171
5/1	1036
6/1	717
7/1	799
8/1	92

Lane Saturation Flows

Junction: A160 Humber Road / Eastfield Road								
Lane	Lane Width (m)	Gradient	Nearside Lane	Allowed Turns	Turning Radius (m)	Turning Prop.	Sat Flow (PCU/Hr)	Flared Sat Flow (PCU/Hr)
1/1 (A160 WB)	3.51	0.00	Y	Arm 5 Ahead Arm 8 Left	Inf 23.56	95.5 % 4.5 %	1960	1960
1/2 (A160 WB)	3.51	0.00	Y	Arm 5 Ahead	Inf	100.0 %	1966	1966
1/3 (A160 WB)	3.40	0.00	Y	Arm 6 Right	20.90	100.0 %	1824	1824
2/1 (Eastfield Road NB)	4.50	0.00	Y	Arm 5 Left Arm 6 Ahead Arm 7 Right	33.50 Inf 32.95	65.1 % 15.3 % 19.6 %	1989	1989
3/1 (A160 EB)	3.30	0.00	N	Arm 6 Left	27.80	100.0 %	1978	1978
3/2 (A160 EB)	3.41	0.00	Y	Arm 7 Ahead	Inf	100.0 %	1956	1956
3/3 (A160 EB)	3.35	0.00	Y	Arm 7 Ahead	Inf	100.0 %	1950	1950
3/4 (A160 EB)	3.42	0.00	Y	Arm 8 Right	23.00	100.0 %	1837	1837
4/1 (Eastfield Road SB)	4.20	0.00	Y	Arm 7 Left	20.00	100.0 %	1893	1893
4/2 (Eastfield Road SB)	4.20	0.00	Y	Arm 5 Right Arm 8 Ahead	25.00 Inf	88.3 % 11.7 %	1933	1933
5/1 (A160 WB Exit Lane 1)	Infinite Saturation Flow						Inf	Inf
6/1 (Eastfield Rd NB Exit Lane 1)	Infinite Saturation Flow						Inf	Inf
7/1 (A160 EB Exit Lane 1)	Infinite Saturation Flow						Inf	Inf
8/1 (Eastfield Road SB Exit Lane 1)	Infinite Saturation Flow						Inf	Inf

Scenario 2: 'PM 2025 Base' (FG2: 'PM 2025 Base', Plan 1: 'Network Control Plan 1')

Traffic Flows, Desired

Desired Flow :

Origin	Destination					
	A	B	C	D	Tot.	
A	0	20	800	83	903	
B	23	0	158	26	207	
C	580	29	0	178	787	
D	120	54	450	0	624	
Tot.	723	103	1408	287	2521	

Full Input Data And Results

Traffic Lane Flows

Lane	Scenario 2: PM 2025 Base
Junction: A160 Humber Road / Eastfield Road	
1/1	400
1/2 (with short)	503(In) 420(Out)
1/3 (short)	83
2/1	207
3/1 (short)	178
3/2 (with short)	484(In) 306(Out)
3/3 (with short)	303(In) 274(Out)
3/4 (short)	29
4/1	120
4/2	504
5/1	1408
6/1	287
7/1	723
8/1	103

Lane Saturation Flows

Junction: A160 Humber Road / Eastfield Road								
Lane	Lane Width (m)	Gradient	Nearside Lane	Allowed Turns	Turning Radius (m)	Turning Prop.	Sat Flow (PCU/Hr)	Flared Sat Flow (PCU/Hr)
1/1 (A160 WB)	3.51	0.00	Y	Arm 5 Ahead Arm 8 Left	Inf 23.56	95.0 % 5.0 %	1960	1960
1/2 (A160 WB)	3.51	0.00	Y	Arm 5 Ahead	Inf	100.0 %	1966	1966
1/3 (A160 WB)	3.40	0.00	Y	Arm 6 Right	20.90	100.0 %	1824	1824
2/1 (Eastfield Road NB)	4.50	0.00	Y	Arm 5 Left Arm 6 Ahead Arm 7 Right	33.50 Inf 32.95	76.3 % 12.6 % 11.1 %	1987	1987
3/1 (A160 EB)	3.30	0.00	N	Arm 6 Left	27.80	100.0 %	1978	1978
3/2 (A160 EB)	3.41	0.00	Y	Arm 7 Ahead	Inf	100.0 %	1956	1956
3/3 (A160 EB)	3.35	0.00	Y	Arm 7 Ahead	Inf	100.0 %	1950	1950
3/4 (A160 EB)	3.42	0.00	Y	Arm 8 Right	23.00	100.0 %	1837	1837
4/1 (Eastfield Road SB)	4.20	0.00	Y	Arm 7 Left	20.00	100.0 %	1893	1893
4/2 (Eastfield Road SB)	4.20	0.00	Y	Arm 5 Right Arm 8 Ahead	25.00 Inf	89.3 % 10.7 %	1932	1932
5/1 (A160 WB Exit Lane 1)	Infinite Saturation Flow						Inf	Inf
6/1 (Eastfield Rd NB Exit Lane 1)	Infinite Saturation Flow						Inf	Inf
7/1 (A160 EB Exit Lane 1)	Infinite Saturation Flow						Inf	Inf
8/1 (Eastfield Road SB Exit Lane 1)	Infinite Saturation Flow						Inf	Inf

Scenario 3: 'AM 2025 Base + Committed' (FG3: 'AM 2025 Base + Committed', Plan 1: 'Network Control Plan 1')

Traffic Flows, Desired

Desired Flow :

Origin	Destination					
	A	B	C	D	Tot.	
A	0	27	771	100	898	
B	38	0	123	34	195	
C	753	54	0	807	1614	
D	58	25	151	0	234	
Tot.	849	106	1045	941	2941	

Full Input Data And Results

Traffic Lane Flows

Lane	Scenario 3: AM 2025 Base + Committed
Junction: A160 Humber Road / Eastfield Road	
1/1	408
1/2 (with short)	490(In) 390(Out)
1/3 (short)	100
2/1	195
3/1 (short)	807
3/2 (with short)	1202(In) 395(Out)
3/3 (with short)	412(In) 358(Out)
3/4 (short)	54
4/1	58
4/2	176
5/1	1045
6/1	941
7/1	849
8/1	106

Lane Saturation Flows

Junction: A160 Humber Road / Eastfield Road								
Lane	Lane Width (m)	Gradient	Nearside Lane	Allowed Turns	Turning Radius (m)	Turning Prop.	Sat Flow (PCU/Hr)	Flared Sat Flow (PCU/Hr)
1/1 (A160 WB)	3.51	0.00	Y	Arm 5 Ahead Arm 8 Left	Inf 23.56	93.4 % 6.6 %	1958	1958
1/2 (A160 WB)	3.51	0.00	Y	Arm 5 Ahead	Inf	100.0 %	1966	1966
1/3 (A160 WB)	3.40	0.00	Y	Arm 6 Right	20.90	100.0 %	1824	1824
2/1 (Eastfield Road NB)	4.50	0.00	Y	Arm 5 Left Arm 6 Ahead Arm 7 Right	33.50 Inf 32.95	63.1 % 17.4 % 19.5 %	1991	1991
3/1 (A160 EB)	3.30	0.00	N	Arm 6 Left	27.80	100.0 %	1978	1978
3/2 (A160 EB)	3.41	0.00	Y	Arm 7 Ahead	Inf	100.0 %	1956	1956
3/3 (A160 EB)	3.35	0.00	Y	Arm 7 Ahead	Inf	100.0 %	1950	1950
3/4 (A160 EB)	3.42	0.00	Y	Arm 8 Right	23.00	100.0 %	1837	1837
4/1 (Eastfield Road SB)	4.20	0.00	Y	Arm 7 Left	20.00	100.0 %	1893	1893
4/2 (Eastfield Road SB)	4.20	0.00	Y	Arm 5 Right Arm 8 Ahead	25.00 Inf	85.8 % 14.2 %	1935	1935
5/1 (A160 WB Exit Lane 1)	Infinite Saturation Flow						Inf	Inf
6/1 (Eastfield Rd NB Exit Lane 1)	Infinite Saturation Flow						Inf	Inf
7/1 (A160 EB Exit Lane 1)	Infinite Saturation Flow						Inf	Inf
8/1 (Eastfield Road SB Exit Lane 1)	Infinite Saturation Flow						Inf	Inf

Scenario 4: 'PM 2025 Base + Committed' (FG4: 'PM 2025 Base + Committed', Plan 1: 'Network Control Plan 1')

Traffic Flows, Desired

Desired Flow :

Origin	Destination					
	A	B	C	D	Tot.	
A	0	20	1045	83	1148	
B	25	0	158	26	209	
C	629	35	0	184	848	
D	122	54	450	0	626	
Tot.	776	109	1653	293	2831	

Full Input Data And Results

Traffic Lane Flows

Lane	Scenario 4: PM 2025 Base + Committed
Junction: A160 Humber Road / Eastfield Road	
1/1	519
1/2 (with short)	629(In) 546(Out)
1/3 (short)	83
2/1	209
3/1 (short)	184
3/2 (with short)	511(In) 327(Out)
3/3 (with short)	337(In) 302(Out)
3/4 (short)	35
4/1	122
4/2	504
5/1	1653
6/1	293
7/1	776
8/1	109

Lane Saturation Flows

Junction: A160 Humber Road / Eastfield Road								
Lane	Lane Width (m)	Gradient	Nearside Lane	Allowed Turns	Turning Radius (m)	Turning Prop.	Sat Flow (PCU/Hr)	Flared Sat Flow (PCU/Hr)
1/1 (A160 WB)	3.51	0.00	Y	Arm 5 Ahead Arm 8 Left	Inf 23.56	96.1 % 3.9 %	1961	1961
1/2 (A160 WB)	3.51	0.00	Y	Arm 5 Ahead	Inf	100.0 %	1966	1966
1/3 (A160 WB)	3.40	0.00	Y	Arm 6 Right	20.90	100.0 %	1824	1824
2/1 (Eastfield Road NB)	4.50	0.00	Y	Arm 5 Left Arm 6 Ahead Arm 7 Right	33.50 Inf 32.95	75.6 % 12.4 % 12.0 %	1987	1987
3/1 (A160 EB)	3.30	0.00	N	Arm 6 Left	27.80	100.0 %	1978	1978
3/2 (A160 EB)	3.41	0.00	Y	Arm 7 Ahead	Inf	100.0 %	1956	1956
3/3 (A160 EB)	3.35	0.00	Y	Arm 7 Ahead	Inf	100.0 %	1950	1950
3/4 (A160 EB)	3.42	0.00	Y	Arm 8 Right	23.00	100.0 %	1837	1837
4/1 (Eastfield Road SB)	4.20	0.00	Y	Arm 7 Left	20.00	100.0 %	1893	1893
4/2 (Eastfield Road SB)	4.20	0.00	Y	Arm 5 Right Arm 8 Ahead	25.00 Inf	89.3 % 10.7 %	1932	1932
5/1 (A160 WB Exit Lane 1)	Infinite Saturation Flow						Inf	Inf
6/1 (Eastfield Rd NB Exit Lane 1)	Infinite Saturation Flow						Inf	Inf
7/1 (A160 EB Exit Lane 1)	Infinite Saturation Flow						Inf	Inf
8/1 (Eastfield Road SB Exit Lane 1)	Infinite Saturation Flow						Inf	Inf

Scenario 5: 'AM 2025 Base + Committed + Proposed' (FG5: 'AM 2025 Base + Committed + Proposed', Plan 1: 'Network Control Plan 1')

Traffic Flows, Desired

Desired Flow :

Origin	Destination					
	A	B	C	D	Tot.	
A	0	25	769	111	905	
B	38	0	123	34	195	
C	771	59	0	1011	1841	
D	58	25	151	0	234	
Tot.	867	109	1043	1156	3175	

Full Input Data And Results

Traffic Lane Flows

Lane	Scenario 5: AM 2025 Base + Committed + Proposed
Junction: A160 Humber Road / Eastfield Road	
1/1	410
1/2 (with short)	495(In) 384(Out)
1/3 (short)	111
2/1	195
3/1 (short)	1011
3/2 (with short)	1349(In) 338(Out)
3/3 (with short)	492(In) 433(Out)
3/4 (short)	59
4/1	58
4/2	176
5/1	1043
6/1	1156
7/1	867
8/1	109

Full Input Data And Results

Lane Saturation Flows

Junction: A160 Humber Road / Eastfield Road								
Lane	Lane Width (m)	Gradient	Nearside Lane	Allowed Turns	Turning Radius (m)	Turning Prop.	Sat Flow (PCU/Hr)	Flared Sat Flow (PCU/Hr)
1/1 (A160 WB)	3.51	0.00	Y	Arm 5 Ahead Arm 8 Left	Inf 23.56	93.9 % 6.1 %	1958	1958
1/2 (A160 WB)	3.51	0.00	Y	Arm 5 Ahead	Inf	100.0 %	1966	1966
1/3 (A160 WB)	3.40	0.00	Y	Arm 6 Right	20.90	100.0 %	1824	1824
2/1 (Eastfield Road NB)	4.50	0.00	Y	Arm 5 Left Arm 6 Ahead Arm 7 Right	33.50 Inf 32.95	63.1 % 17.4 % 19.5 %	1991	1991
3/1 (A160 EB)	3.30	0.00	N	Arm 6 Left	27.80	100.0 %	1978	1978
3/2 (A160 EB)	3.41	0.00	Y	Arm 7 Ahead	Inf	100.0 %	1956	1956
3/3 (A160 EB)	3.35	0.00	Y	Arm 7 Ahead	Inf	100.0 %	1950	1950
3/4 (A160 EB)	3.42	0.00	Y	Arm 8 Right	23.00	100.0 %	1837	1837
4/1 (Eastfield Road SB)	4.20	0.00	Y	Arm 7 Left	20.00	100.0 %	1893	1893
4/2 (Eastfield Road SB)	4.20	0.00	Y	Arm 5 Right Arm 8 Ahead	25.00 Inf	85.8 % 14.2 %	1935	1935
5/1 (A160 WB Exit Lane 1)	Infinite Saturation Flow						Inf	Inf
6/1 (Eastfield Rd NB Exit Lane 1)	Infinite Saturation Flow						Inf	Inf
7/1 (A160 EB Exit Lane 1)	Infinite Saturation Flow						Inf	Inf
8/1 (Eastfield Road SB Exit Lane 1)	Infinite Saturation Flow						Inf	Inf

Scenario 6: 'PM 2025 Base + Committed + Propsoed' (FG6: 'PM 2025 Base + Committed + Proposed', Plan 1: 'Network Control Plan 1')

Traffic Flows, Desired

Desired Flow :

Origin	Destination					
	A	B	C	D	Tot.	
A	0	29	1065	92	1186	
B	25	0	158	26	209	
C	631	37	0	186	854	
D	135	54	636	0	825	
Tot.	791	120	1859	304	3074	

Full Input Data And Results

Traffic Lane Flows

Lane	Scenario 6: PM 2025 Base + Committed + Propsoed
Junction: A160 Humber Road / Eastfield Road	
1/1	536
1/2 (with short)	650(In) 558(Out)
1/3 (short)	92
2/1	209
3/1 (short)	186
3/2 (with short)	512(In) 326(Out)
3/3 (with short)	342(In) 305(Out)
3/4 (short)	37
4/1	135
4/2	690
5/1	1859
6/1	304
7/1	791
8/1	120

Lane Saturation Flows

Junction: A160 Humber Road / Eastfield Road								
Lane	Lane Width (m)	Gradient	Nearside Lane	Allowed Turns	Turning Radius (m)	Turning Prop.	Sat Flow (PCU/Hr)	Flared Sat Flow (PCU/Hr)
1/1 (A160 WB)	3.51	0.00	Y	Arm 5 Ahead Arm 8 Left	Inf 23.56	94.6 % 5.4 %	1959	1959
1/2 (A160 WB)	3.51	0.00	Y	Arm 5 Ahead	Inf	100.0 %	1966	1966
1/3 (A160 WB)	3.40	0.00	Y	Arm 6 Right	20.90	100.0 %	1824	1824
2/1 (Eastfield Road NB)	4.50	0.00	Y	Arm 5 Left Arm 6 Ahead Arm 7 Right	33.50 Inf 32.95	75.6 % 12.4 % 12.0 %	1987	1987
3/1 (A160 EB)	3.30	0.00	N	Arm 6 Left	27.80	100.0 %	1978	1978
3/2 (A160 EB)	3.41	0.00	Y	Arm 7 Ahead	Inf	100.0 %	1956	1956
3/3 (A160 EB)	3.35	0.00	Y	Arm 7 Ahead	Inf	100.0 %	1950	1950
3/4 (A160 EB)	3.42	0.00	Y	Arm 8 Right	23.00	100.0 %	1837	1837
4/1 (Eastfield Road SB)	4.20	0.00	Y	Arm 7 Left	20.00	100.0 %	1893	1893
4/2 (Eastfield Road SB)	4.20	0.00	Y	Arm 5 Right Arm 8 Ahead	25.00 Inf	92.2 % 7.8 %	1928	1928
5/1 (A160 WB Exit Lane 1)	Infinite Saturation Flow						Inf	Inf
6/1 (Eastfield Rd NB Exit Lane 1)	Infinite Saturation Flow						Inf	Inf
7/1 (A160 EB Exit Lane 1)	Infinite Saturation Flow						Inf	Inf
8/1 (Eastfield Road SB Exit Lane 1)	Infinite Saturation Flow						Inf	Inf

Scenario 1: 'AM 2025 Base' (FG1: 'AM 2025 Base', Plan 1: 'Network Control Plan 1')

Stage Sequence Diagram

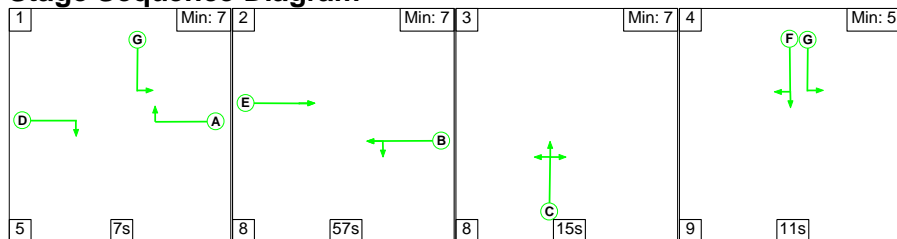

Stage Timings

Stage	1	2	3	4
Duration	7	57	15	11
Change Point	0	12	77	100

Signal Timings Diagram

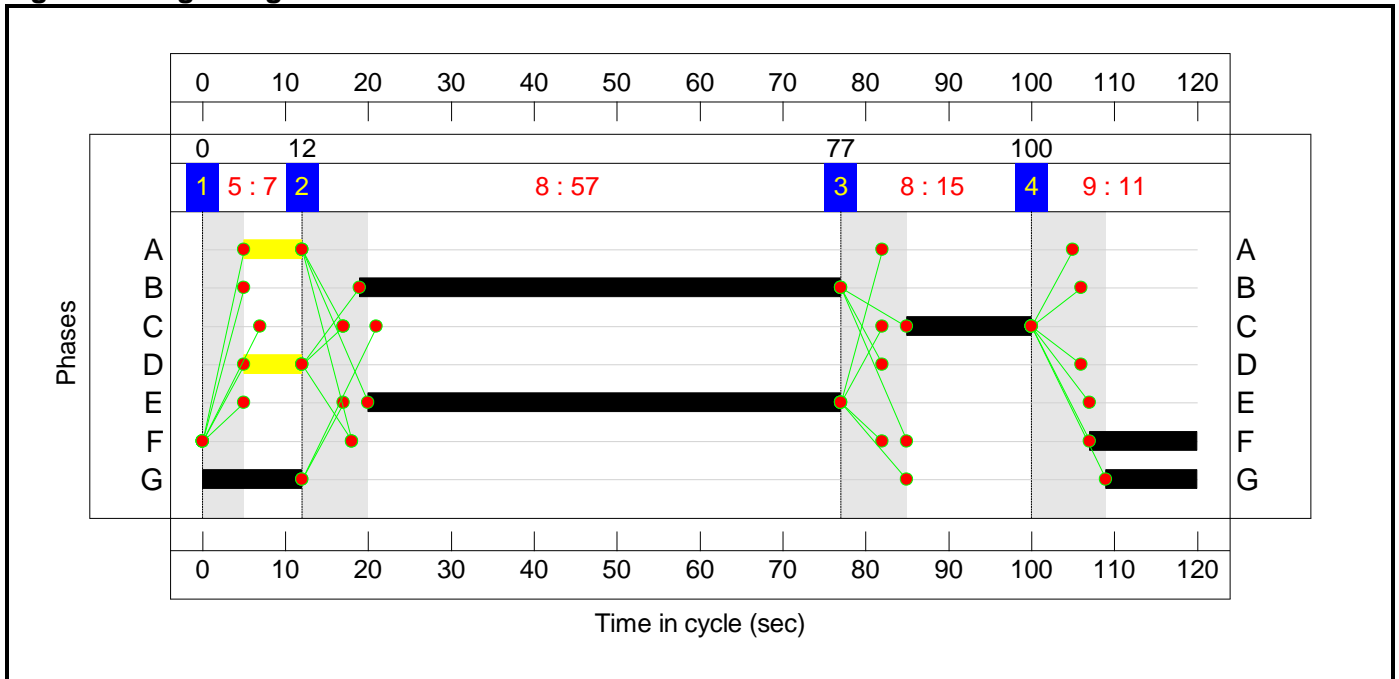

Full Input Data And Results
Network Layout Diagram

Full Input Data And Results

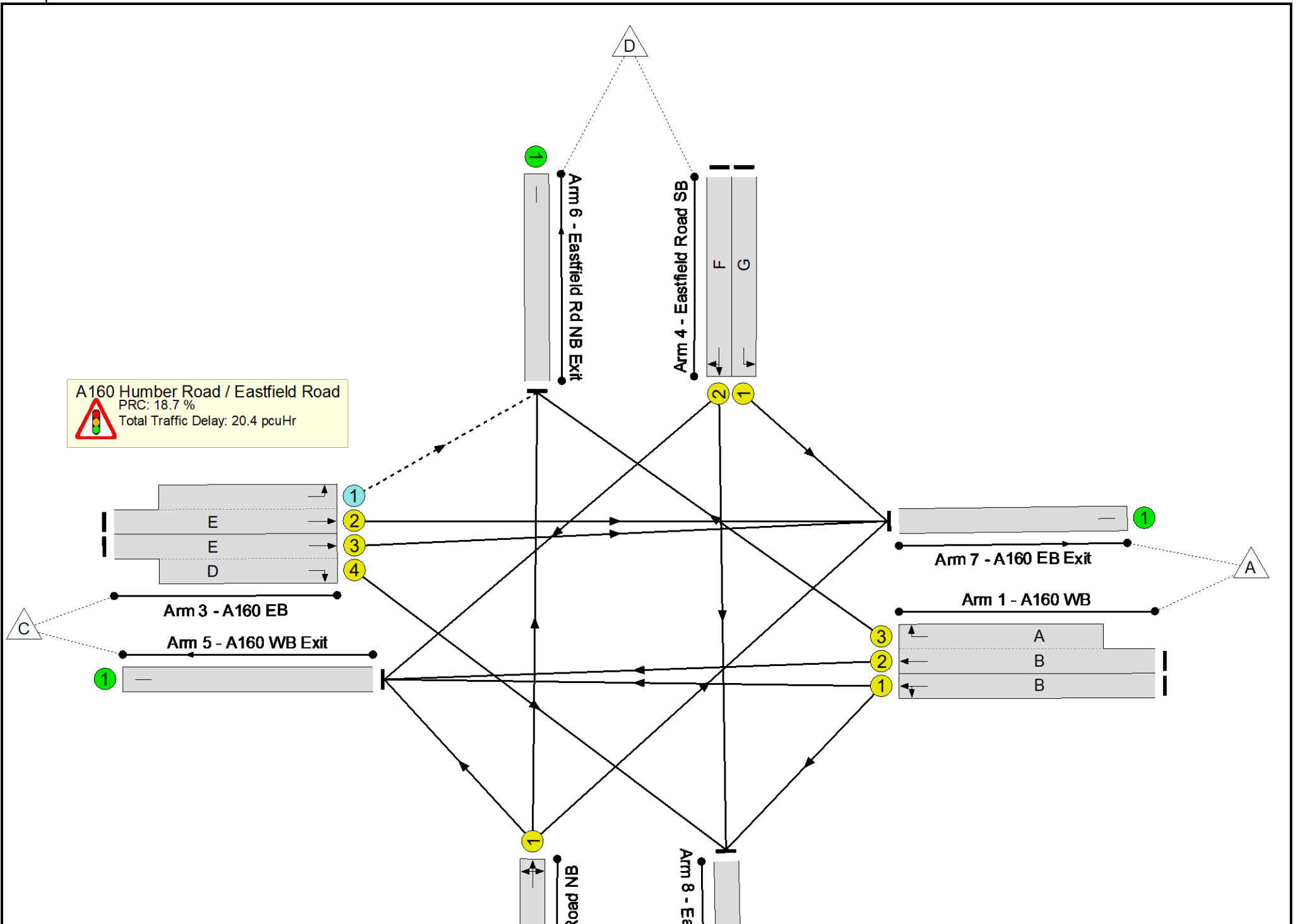

Full Input Data And Results

Network Results

Item	Lane Description	Lane Type	Controller Stream	Position In Filtered Route	Full Phase	Arrow Phase	Num Greens	Total Green (s)	Arrow Green (s)	Demand Flow (pcu)	Sat Flow (pcu/Hr)	Capacity (pcu)	Deg Sat (%)
Network	-	-	N/A	-	-		-	-	-	-	-	-	75.8%
A160 Humber Road / Eastfield Road	-	-	N/A	-	-		-	-	-	-	-	-	75.8%
1/1	A160 WB Ahead Left	U	N/A	N/A	B		1	58	-	397	1960	964	41.2%
1/2+1/3	A160 WB Ahead Right	U	N/A	N/A	B A		1	58:7	-	474	1966:1824	887+122	43.2 : 74.8%
2/1	Eastfield Road NB Left Ahead Right	U	N/A	N/A	C		1	15	-	189	1989	265	71.3%
3/2+3/1	A160 EB Left Ahead	U+O	N/A	N/A	E -		1	57	-	972	1956:1978	697+1109	53.8 : 53.8%
3/3+3/4	A160 EB Ahead Right	U	N/A	N/A	E D		1	57:7	-	384	1950:1837	928+122	35.6 : 44.1%
4/1	Eastfield Road SB Left	U	N/A	N/A	G		1	23	-	57	1893	379	15.1%
4/2	Eastfield Road SB Right Ahead	U	N/A	N/A	F		1	13	-	171	1933	226	75.8%
5/1	A160 WB Exit	U	N/A	N/A	-		-	-	-	1036	Inf	Inf	0.0%
6/1	Eastfield Rd NB Exit	U	N/A	N/A	-		-	-	-	717	Inf	Inf	0.0%
7/1	A160 EB Exit	U	N/A	N/A	-		-	-	-	799	Inf	Inf	0.0%
8/1	Eastfield Road SB Exit	U	N/A	N/A	-		-	-	-	92	Inf	Inf	0.0%

Full Input Data And Results

Item	Arriving (pcu)	Leaving (pcu)	Turners In Gaps (pcu)	Turners When Unopposed (pcu)	Turners In Intergreen (pcu)	Uniform Delay (pcuHr)	Rand + Oversat Delay (pcuHr)	Storage Area Uniform Delay (pcuHr)	Total Delay (pcuHr)	Av. Delay Per PCU (s/pcu)	Max. Back of Uniform Queue (pcu)	Rand + Oversat Queue (pcu)	Mean Max Queue (pcu)
Network	-	-	102	495	0	16.0	4.4	0.0	20.4	-	-	-	-
A160 Humber Road / Eastfield Road	-	-	102	495	0	16.0	4.4	0.0	20.4	-	-	-	-
1/1	397	397	-	-	-	2.1	0.3	-	2.5	22.6	8.4	0.3	8.7
1/2+1/3	474	474	-	-	-	3.4	0.4	-	3.9	29.5	8.0	0.4	8.4
2/1	189	189	-	-	-	2.6	1.2	-	3.8	72.7	6.0	1.2	7.2
3/2+3/1	972	972	102	495	0	2.1	0.6	-	2.7	10.0	7.9	0.6	8.5
3/3+3/4	384	384	-	-	-	2.6	0.3	-	2.9	26.8	6.8	0.3	7.1
4/1	57	57	-	-	-	0.6	0.1	-	0.7	45.2	1.6	0.1	1.6
4/2	171	171	-	-	-	2.4	1.5	-	3.9	82.7	5.5	1.5	7.0
5/1	1036	1036	-	-	-	0.0	0.0	-	0.0	0.0	0.0	0.0	0.0
6/1	717	717	-	-	-	0.0	0.0	-	0.0	0.0	0.0	0.0	0.0
7/1	799	799	-	-	-	0.0	0.0	-	0.0	0.0	0.0	0.0	0.0
8/1	92	92	-	-	-	0.0	0.0	-	0.0	0.0	0.0	0.0	0.0
C1			PRC for Signalled Lanes (%):		18.7	Total Delay for Signalled Lanes (pcuHr):			20.39	Cycle Time (s): 120			
			PRC Over All Lanes (%):		18.7	Total Delay Over All Lanes (pcuHr):			20.39				

Full Input Data And Results

Scenario 2: 'PM 2025 Base' (FG2: 'PM 2025 Base', Plan 1: 'Network Control Plan 1')

Stage Sequence Diagram

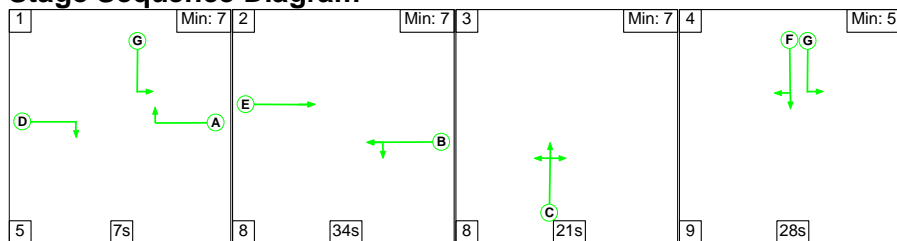

Stage Timings

Stage	1	2	3	4
Duration	7	34	21	28
Change Point	0	12	54	83

Signal Timings Diagram

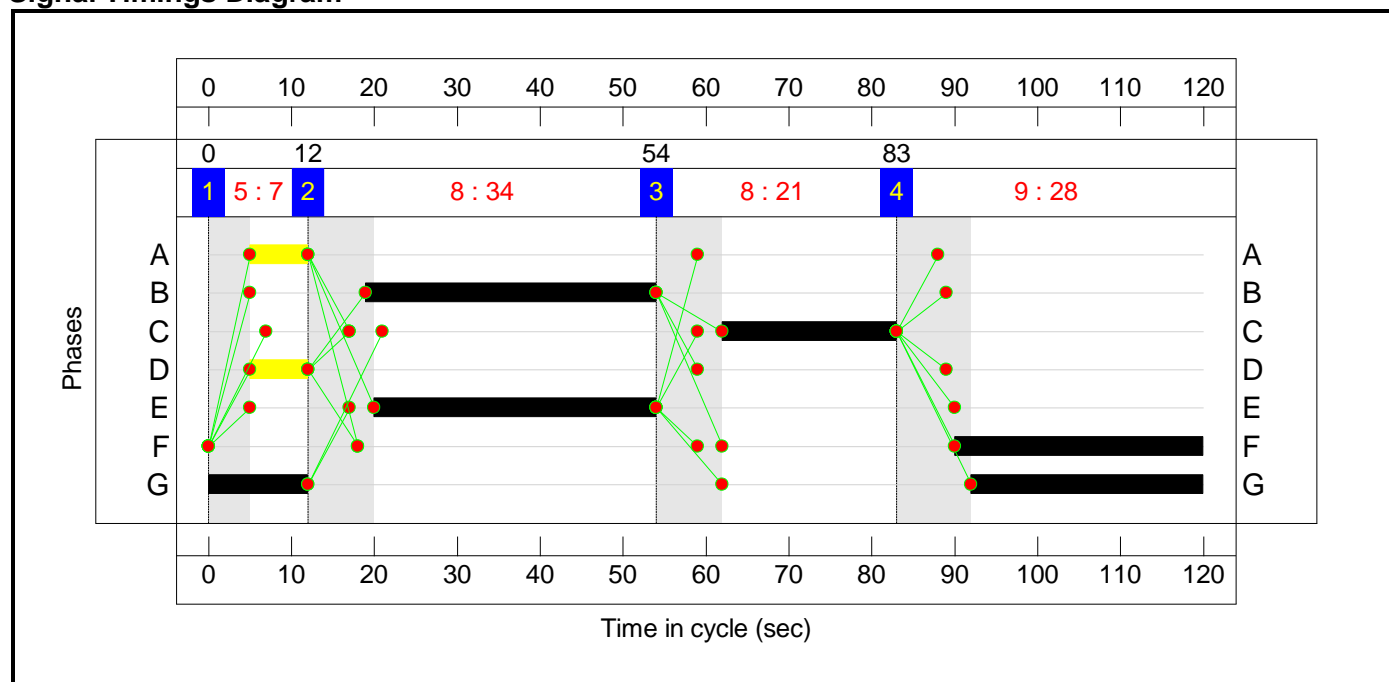

Full Input Data And Results
Network Layout Diagram

Full Input Data And Results

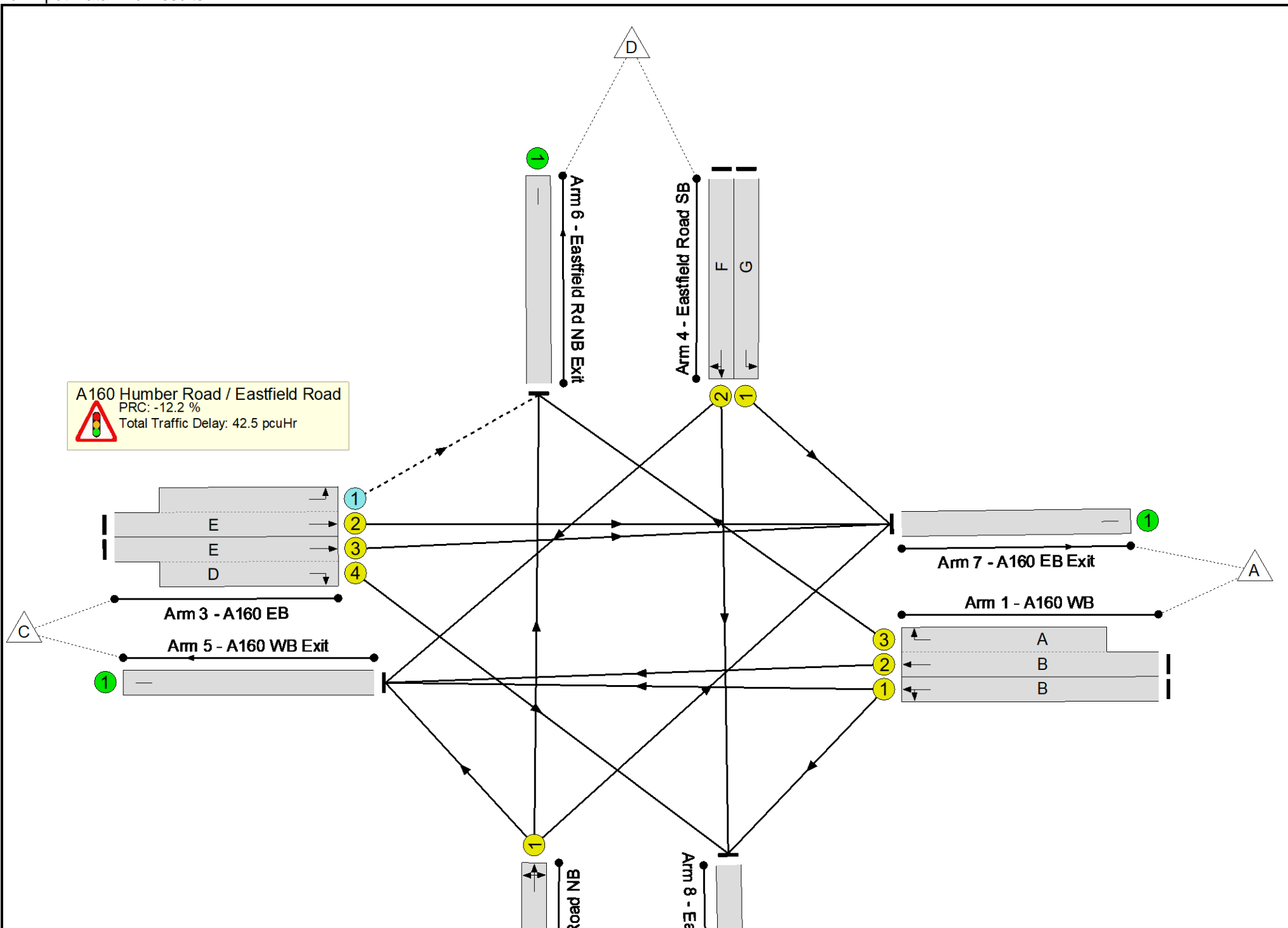

Full Input Data And Results

Network Results

Item	Lane Description	Lane Type	Controller Stream	Position In Filtered Route	Full Phase	Arrow Phase	Num Greens	Total Green (s)	Arrow Green (s)	Demand Flow (pcu)	Sat Flow (pcu/Hr)	Capacity (pcu)	Deg Sat (%)
Network	-	-	N/A	-	-		-	-	-	-	-	-	101.0%
A160 Humber Road / Eastfield Road	-	-	N/A	-	-		-	-	-	-	-	-	101.0%
1/1	A160 WB Ahead Left	U	N/A	N/A	B		1	35	-	400	1960	588	68.0%
1/2+1/3	A160 WB Ahead Right	U	N/A	N/A	B A		1	35:7	-	503	1966:1824	590+122	71.2 : 68.3%
2/1	Eastfield Road NB Left Ahead Right	U	N/A	N/A	C		1	21	-	207	1987	364	56.8%
3/2+3/1	A160 EB Left Ahead	U+O	N/A	N/A	E -		1	34	-	484	1956:1978	564+328	54.2 : 54.2%
3/3+3/4	A160 EB Ahead Right	U	N/A	N/A	E D		1	34:7	-	303	1950:1837	569+75	48.2 : 38.7%
4/1	Eastfield Road SB Left	U	N/A	N/A	G		1	40	-	120	1893	647	18.6%
4/2	Eastfield Road SB Right Ahead	U	N/A	N/A	F		1	30	-	504	1932	499	101.0%
5/1	A160 WB Exit	U	N/A	N/A	-		-	-	-	1408	Inf	Inf	0.0%
6/1	Eastfield Rd NB Exit	U	N/A	N/A	-		-	-	-	287	Inf	Inf	0.0%
7/1	A160 EB Exit	U	N/A	N/A	-		-	-	-	723	Inf	Inf	0.0%
8/1	Eastfield Road SB Exit	U	N/A	N/A	-		-	-	-	103	Inf	Inf	0.0%

Full Input Data And Results

Item	Arriving (pcu)	Leaving (pcu)	Turners In Gaps (pcu)	Turners When Unopposed (pcu)	Turners In Intergreen (pcu)	Uniform Delay (pcuHr)	Rand + Oversat Delay (pcuHr)	Storage Area Uniform Delay (pcuHr)	Total Delay (pcuHr)	Av. Delay Per PCU (s/pcu)	Max. Back of Uniform Queue (pcu)	Rand + Oversat Queue (pcu)	Mean Max Queue (pcu)
Network	-	-	44	133	0	25.9	16.6	0.0	42.5	-	-	-	-
A160 Humber Road / Eastfield Road	-	-	44	133	0	25.9	16.6	0.0	42.5	-	-	-	-
1/1	400	400	-	-	-	4.1	1.1	-	5.2	46.4	11.7	1.1	12.7
1/2+1/3	503	503	-	-	-	5.6	1.2	-	6.8	48.8	12.4	1.2	13.6
2/1	207	207	-	-	-	2.6	0.7	-	3.2	56.0	6.3	0.7	6.9
3/2+3/1	484	484	44	133	0	3.0	0.6	-	3.6	27.0	8.5	0.6	9.1
3/3+3/4	303	303	-	-	-	3.1	0.4	-	3.5	42.0	7.5	0.4	7.9
4/1	120	120	-	-	-	0.9	0.1	-	1.0	31.2	2.8	0.1	2.9
4/2	504	499	-	-	-	6.6	12.5	-	19.1	136.4	17.0	12.5	29.5
5/1	1404	1404	-	-	-	0.0	0.0	-	0.0	0.0	0.0	0.0	0.0
6/1	287	287	-	-	-	0.0	0.0	-	0.0	0.0	0.0	0.0	0.0
7/1	723	723	-	-	-	0.0	0.0	-	0.0	0.0	0.0	0.0	0.0
8/1	102	102	-	-	-	0.0	0.0	-	0.0	0.0	0.0	0.0	0.0
C1			PRC for Signalled Lanes (%):	-12.2	Total Delay for Signalled Lanes (pcuHr):			42.50	Cycle Time (s): 120				
			PRC Over All Lanes (%):	-12.2	Total Delay Over All Lanes(pcuHr):			42.50					

Full Input Data And Results

Scenario 3: 'AM 2025 Base + Committed' (FG3: 'AM 2025 Base + Committed', Plan 1: 'Network Control Plan 1')

Stage Sequence Diagram

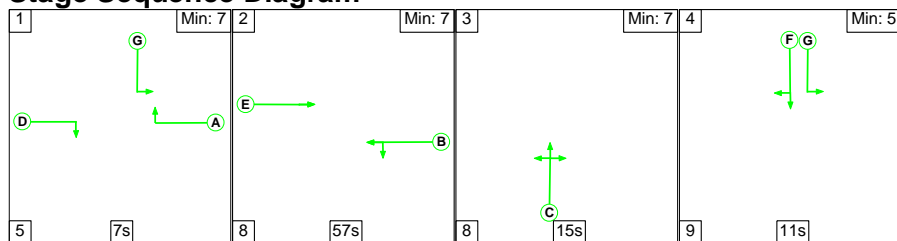

Stage Timings

Stage	1	2	3	4
Duration	7	57	15	11
Change Point	0	12	77	100

Signal Timings Diagram

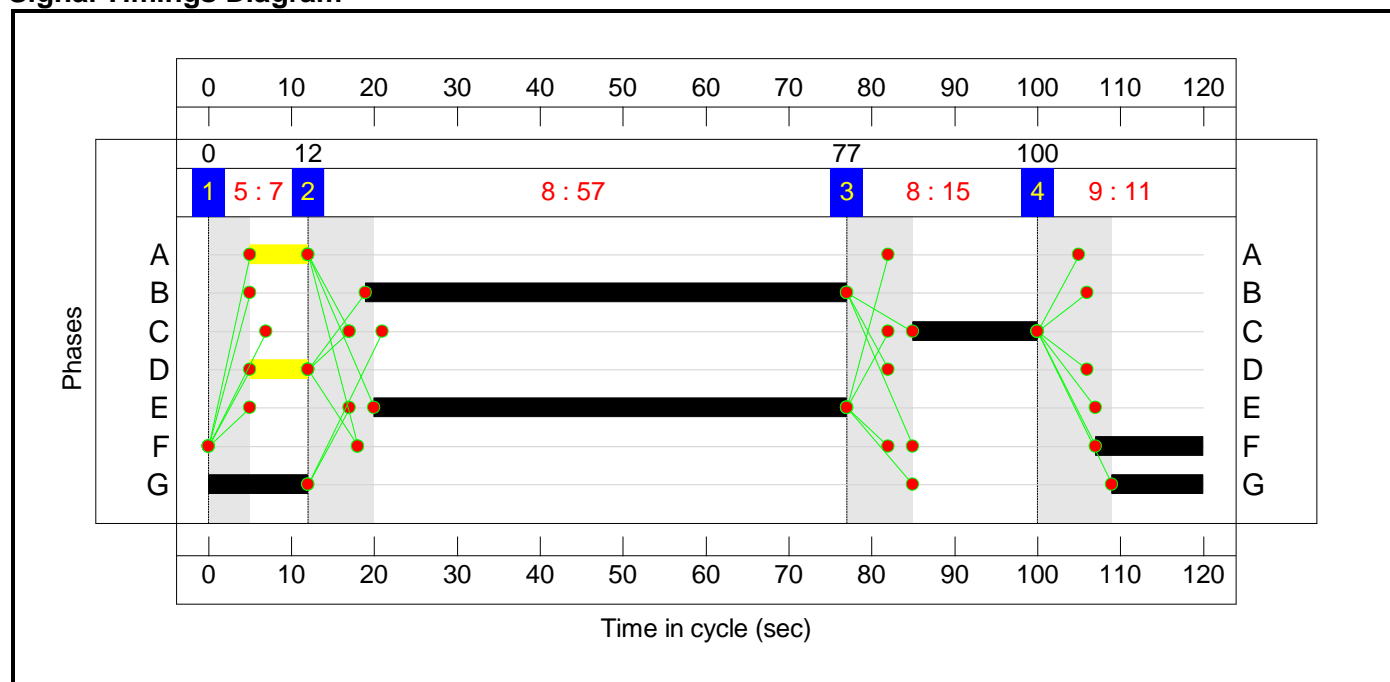

Full Input Data And Results
Network Layout Diagram

Full Input Data And Results

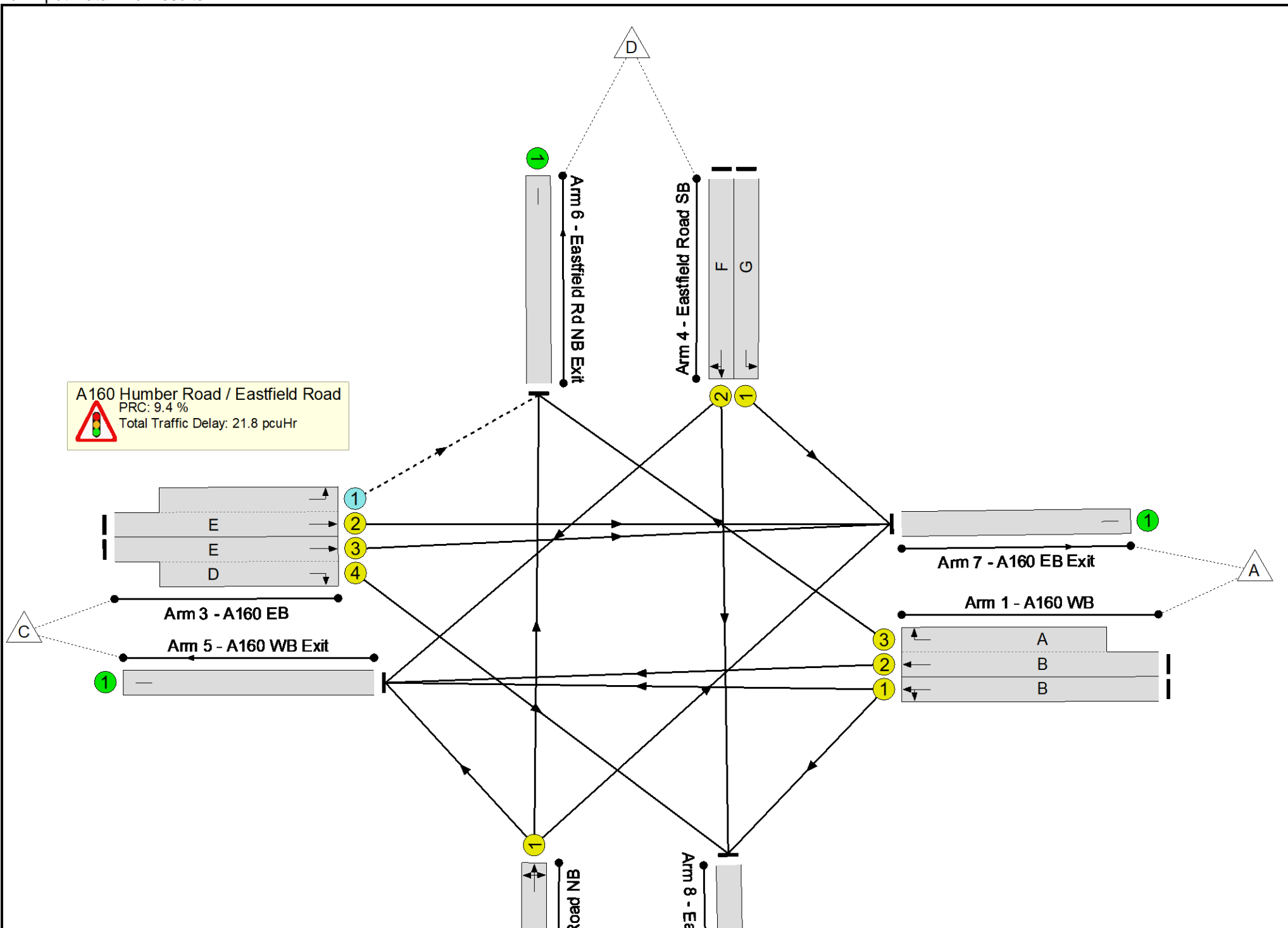

Full Input Data And Results

Network Results

Item	Lane Description	Lane Type	Controller Stream	Position In Filtered Route	Full Phase	Arrow Phase	Num Greens	Total Green (s)	Arrow Green (s)	Demand Flow (pcu)	Sat Flow (pcu/Hr)	Capacity (pcu)	Deg Sat (%)
Network	-	-	N/A	-	-		-	-	-	-	-	-	82.2%
A160 Humber Road / Eastfield Road	-	-	N/A	-	-		-	-	-	-	-	-	82.2%
1/1	A160 WB Ahead Left	U	N/A	N/A	B		1	58	-	408	1958	963	42.4%
1/2+1/3	A160 WB Ahead Right	U	N/A	N/A	B A		1	58:7	-	490	1966:1824	882+122	44.2 : 82.2%
2/1	Eastfield Road NB Left Ahead Right	U	N/A	N/A	C		1	15	-	195	1991	265	73.5%
3/2+3/1	A160 EB Left Ahead	U+O	N/A	N/A	E -		1	57	-	1202	1956:1978	648+1320	61.0 : 61.1%
3/3+3/4	A160 EB Ahead Right	U	N/A	N/A	E D		1	57:7	-	412	1950:1837	930+122	38.5 : 44.1%
4/1	Eastfield Road SB Left	U	N/A	N/A	G		1	23	-	58	1893	379	15.3%
4/2	Eastfield Road SB Right Ahead	U	N/A	N/A	F		1	13	-	176	1935	226	78.0%
5/1	A160 WB Exit	U	N/A	N/A	-		-	-	-	1045	Inf	Inf	0.0%
6/1	Eastfield Rd NB Exit	U	N/A	N/A	-		-	-	-	941	Inf	Inf	0.0%
7/1	A160 EB Exit	U	N/A	N/A	-		-	-	-	849	Inf	Inf	0.0%
8/1	Eastfield Road SB Exit	U	N/A	N/A	-		-	-	-	106	Inf	Inf	0.0%

Full Input Data And Results

Scenario 4: 'PM 2025 Base + Committed' (FG4: 'PM 2025 Base + Committed', Plan 1: 'Network Control Plan 1')

Stage Sequence Diagram

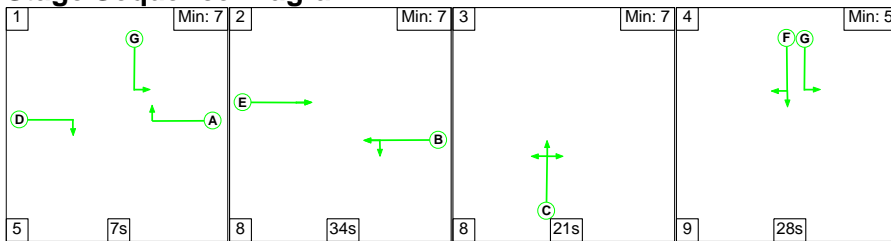

Stage Timings

Stage	1	2	3	4
Duration	7	34	21	28
Change Point	0	12	54	83

Signal Timings Diagram

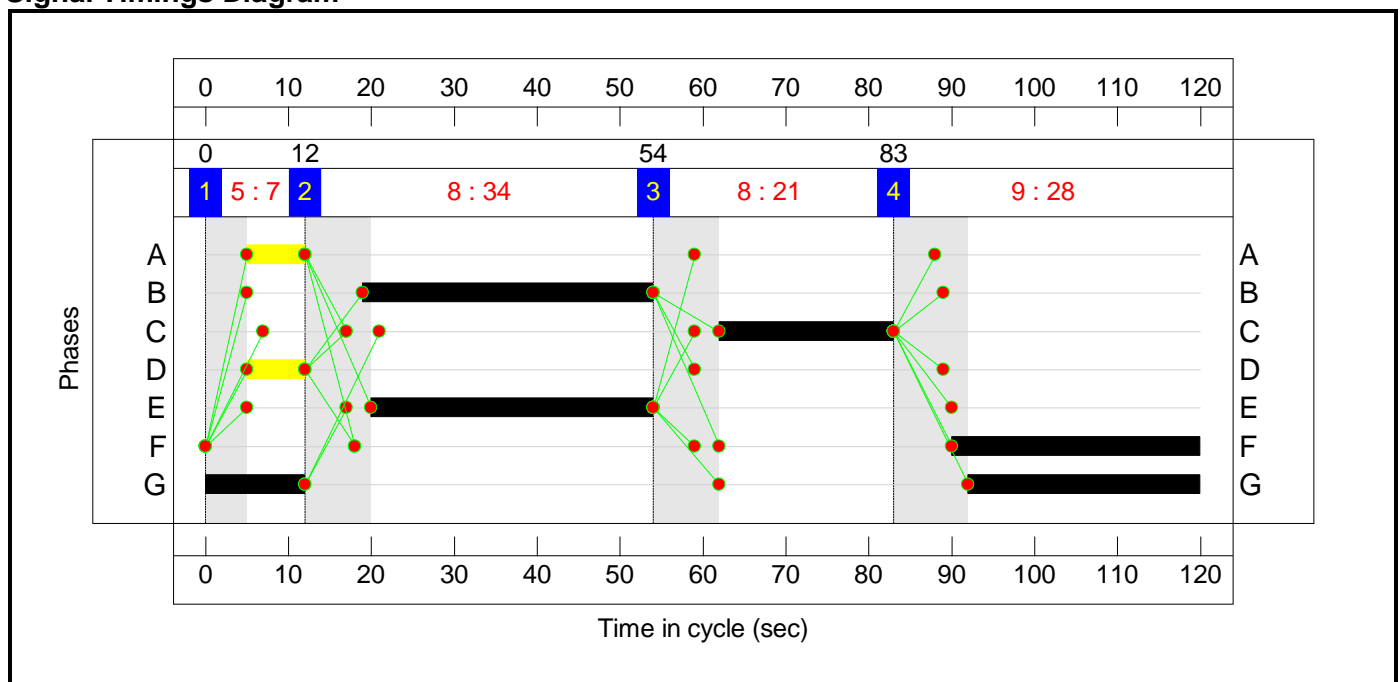

Full Input Data And Results
Network Layout Diagram

Full Input Data And Results

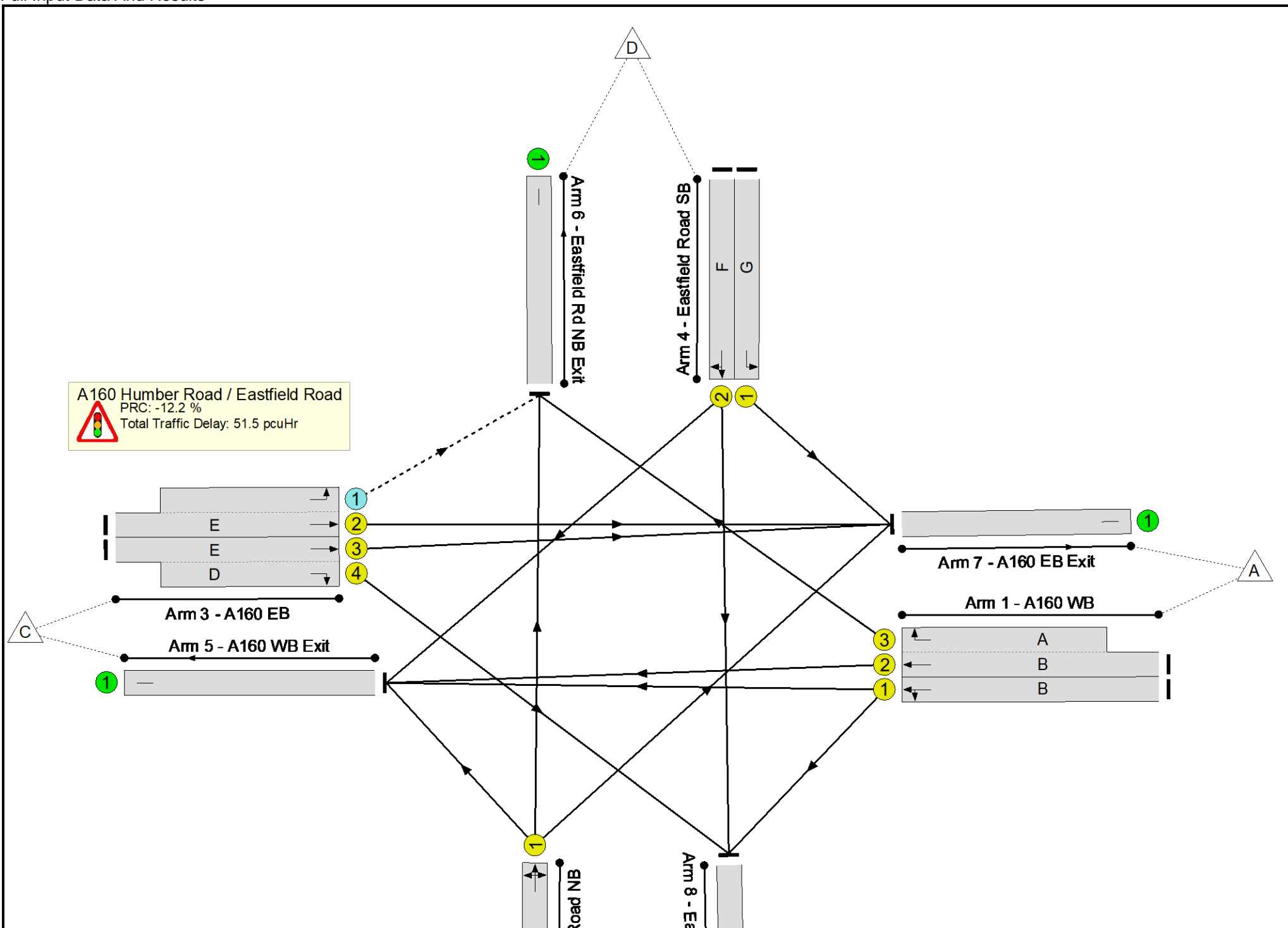

Full Input Data And Results

Network Results

Item	Lane Description	Lane Type	Controller Stream	Position In Filtered Route	Full Phase	Arrow Phase	Num Greens	Total Green (s)	Arrow Green (s)	Demand Flow (pcu)	Sat Flow (pcu/Hr)	Capacity (pcu)	Deg Sat (%)
Network	-	-	N/A	-	-		-	-	-	-	-	-	101.0%
A160 Humber Road / Eastfield Road	-	-	N/A	-	-		-	-	-	-	-	-	101.0%
1/1	A160 WB Ahead Left	U	N/A	N/A	B		1	35	-	519	1961	588	88.2%
1/2+1/3	A160 WB Ahead Right	U	N/A	N/A	B A		1	35:7	-	629	1966:1824	590+122	92.6 : 68.3%
2/1	Eastfield Road NB Left Ahead Right	U	N/A	N/A	C		1	21	-	209	1987	364	57.4%
3/2+3/1	A160 EB Left Ahead	U+O	N/A	N/A	E -		1	34	-	511	1956:1978	565+318	57.9 : 57.9%
3/3+3/4	A160 EB Ahead Right	U	N/A	N/A	E D		1	34:7	-	337	1950:1837	569+93	53.1 : 37.6%
4/1	Eastfield Road SB Left	U	N/A	N/A	G		1	40	-	122	1893	647	18.9%
4/2	Eastfield Road SB Right Ahead	U	N/A	N/A	F		1	30	-	504	1932	499	101.0%
5/1	A160 WB Exit	U	N/A	N/A	-		-	-	-	1653	Inf	Inf	0.0%
6/1	Eastfield Rd NB Exit	U	N/A	N/A	-		-	-	-	293	Inf	Inf	0.0%
7/1	A160 EB Exit	U	N/A	N/A	-		-	-	-	776	Inf	Inf	0.0%
8/1	Eastfield Road SB Exit	U	N/A	N/A	-		-	-	-	109	Inf	Inf	0.0%

Full Input Data And Results

Scenario 5: 'AM 2025 Base + Committed + Proposed' (FG5: 'AM 2025 Base + Committed + Proposed', Plan 1: 'Network Control Plan 1')

Stage Sequence Diagram

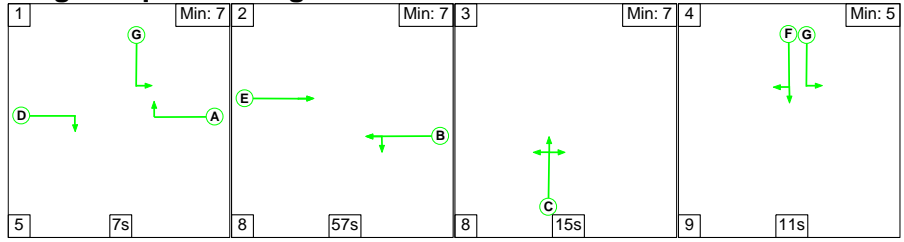

Stage Timings

Stage	1	2	3	4
Duration	7	57	15	11
Change Point	0	12	77	100

Signal Timings Diagram

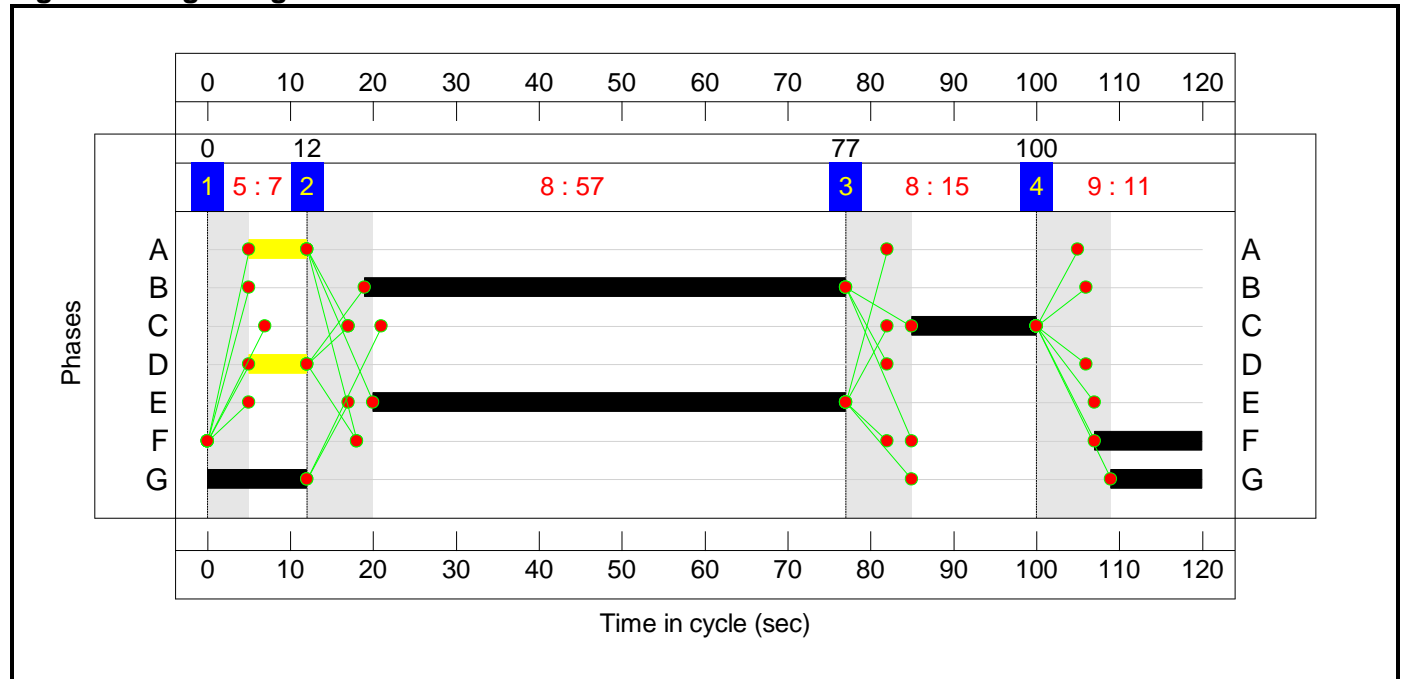

Full Input Data And Results
Network Layout Diagram

Full Input Data And Results

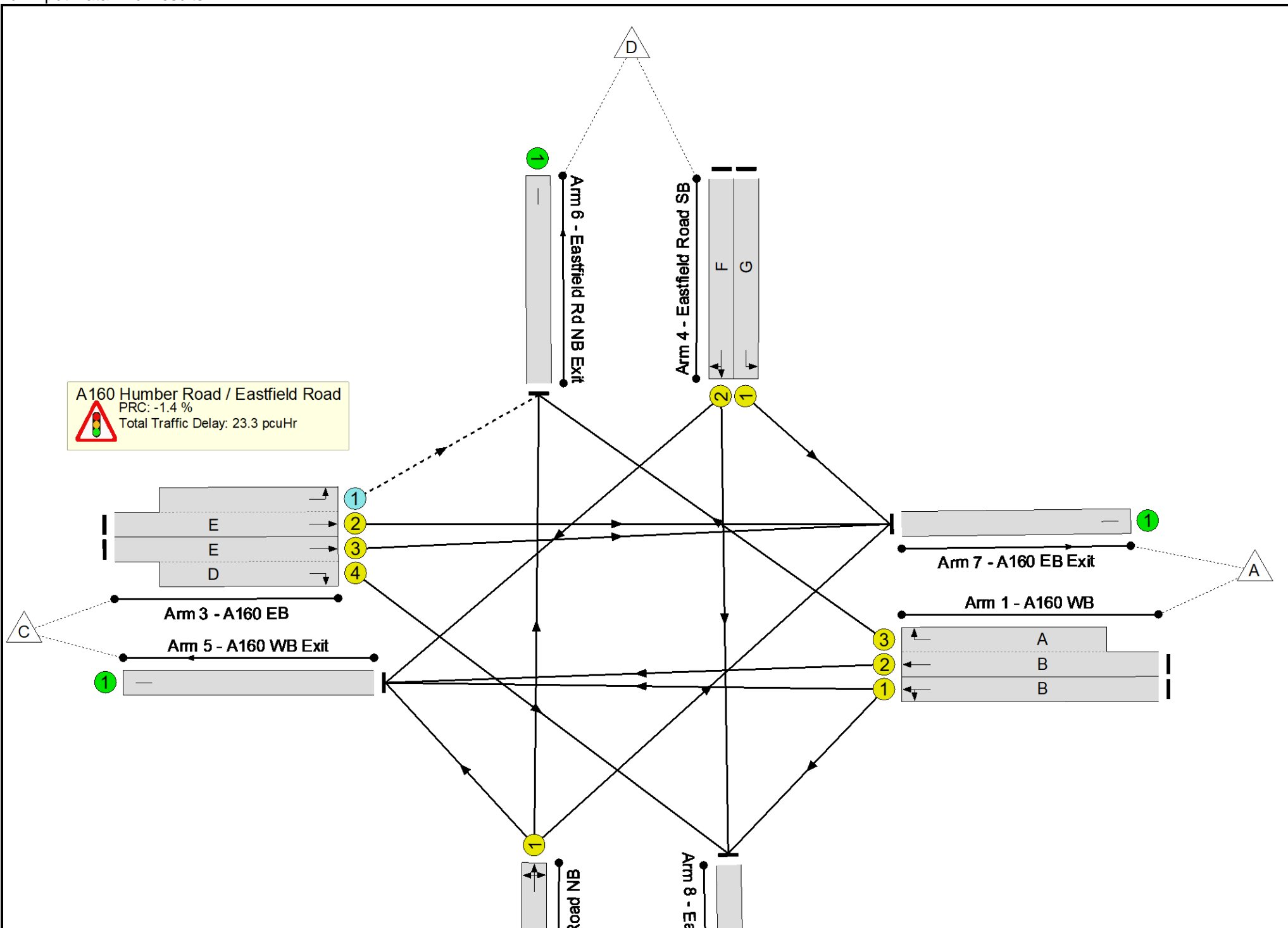

Full Input Data And Results

Network Results

Item	Lane Description	Lane Type	Controller Stream	Position In Filtered Route	Full Phase	Arrow Phase	Num Greens	Total Green (s)	Arrow Green (s)	Demand Flow (pcu)	Sat Flow (pcu/Hr)	Capacity (pcu)	Deg Sat (%)
Network	-	-	N/A	-	-		-	-	-	-	-	-	91.3%
A160 Humber Road / Eastfield Road	-	-	N/A	-	-		-	-	-	-	-	-	91.3%
1/1	A160 WB Ahead Left	U	N/A	N/A	B		1	58	-	410	1958	963	42.6%
1/2+1/3	A160 WB Ahead Right	U	N/A	N/A	B A		1	58:7	-	495	1966:1824	875+122	43.9 : 91.3%
2/1	Eastfield Road NB Left Ahead Right	U	N/A	N/A	C		1	15	-	195	1991	265	73.5%
3/2+3/1	A160 EB Left Ahead	U+O	N/A	N/A	E -		1	57	-	1349	1956:1978	439+1313	77.0 : 77.0%
3/3+3/4	A160 EB Ahead Right	U	N/A	N/A	E D		1	57:7	-	492	1950:1837	932+122	46.5 : 48.2%
4/1	Eastfield Road SB Left	U	N/A	N/A	G		1	23	-	58	1893	379	15.3%
4/2	Eastfield Road SB Right Ahead	U	N/A	N/A	F		1	13	-	176	1935	226	78.0%
5/1	A160 WB Exit	U	N/A	N/A	-		-	-	-	1043	Inf	Inf	0.0%
6/1	Eastfield Rd NB Exit	U	N/A	N/A	-		-	-	-	1156	Inf	Inf	0.0%
7/1	A160 EB Exit	U	N/A	N/A	-		-	-	-	867	Inf	Inf	0.0%
8/1	Eastfield Road SB Exit	U	N/A	N/A	-		-	-	-	109	Inf	Inf	0.0%

Full Input Data And Results

Scenario 6: 'PM 2025 Base + Committed + Propsoed' (FG6: 'PM 2025 Base + Committed + Proposed', Plan 1: 'Network Control Plan 1')

Stage Sequence Diagram

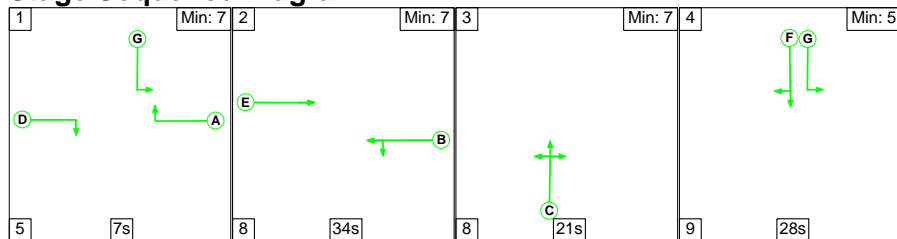

Stage Timings

Stage	1	2	3	4
Duration	7	34	21	28
Change Point	0	12	54	83

Signal Timings Diagram

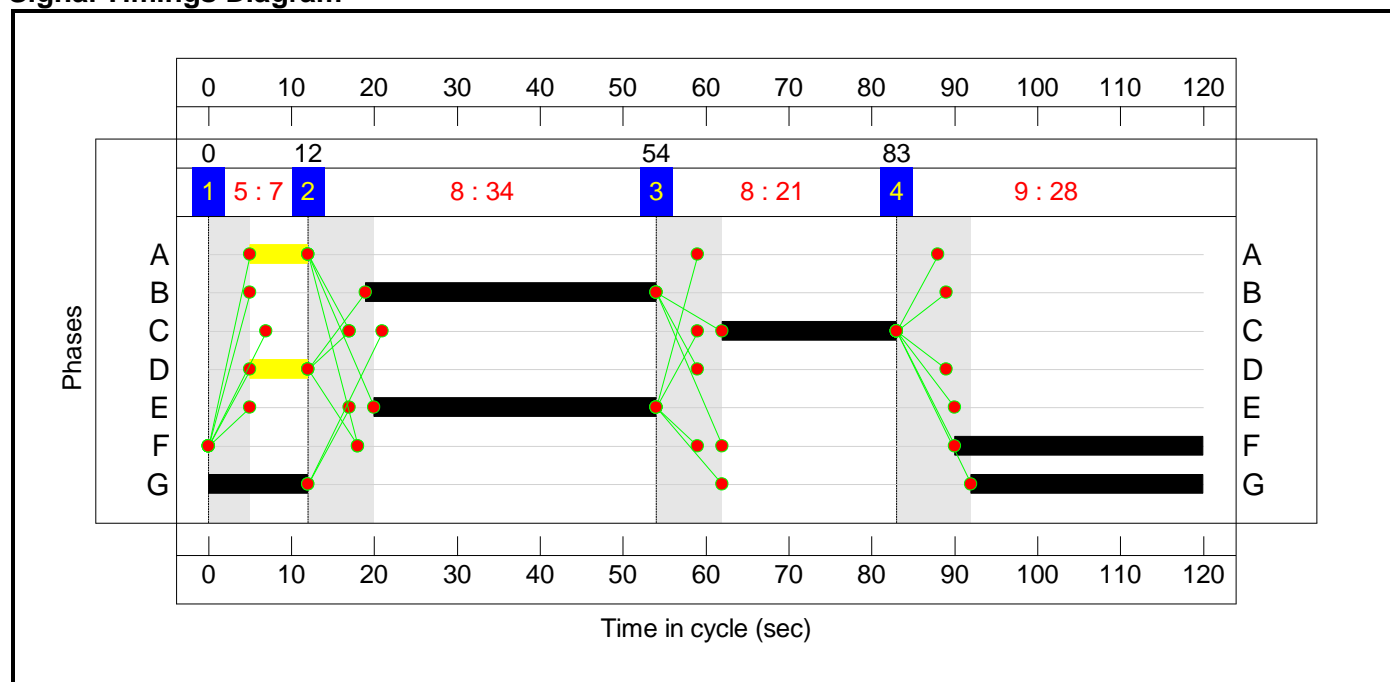

Full Input Data And Results
Network Layout Diagram

Full Input Data And Results

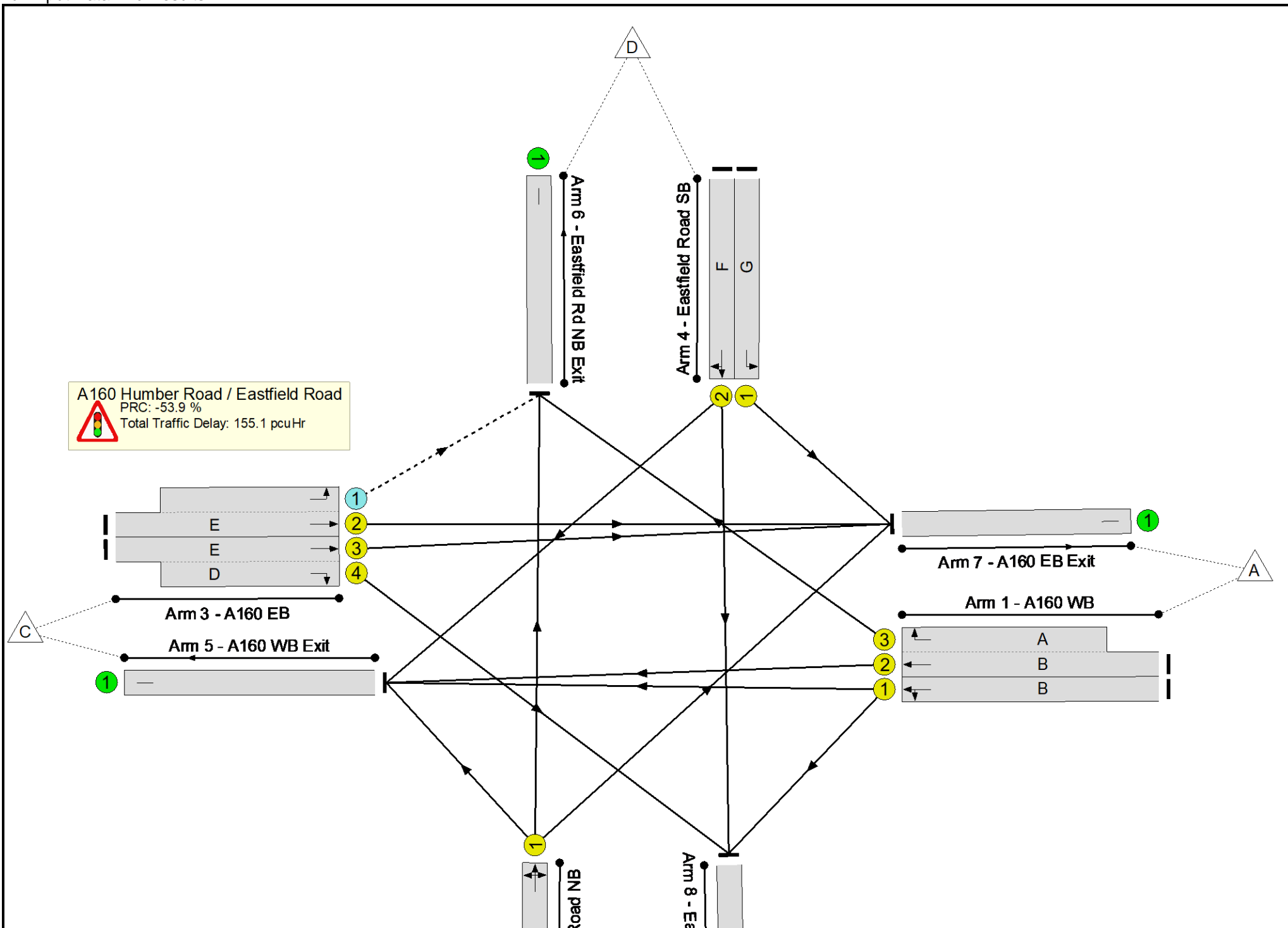

Full Input Data And Results

Network Results

Item	Lane Description	Lane Type	Controller Stream	Position In Filtered Route	Full Phase	Arrow Phase	Num Greens	Total Green (s)	Arrow Green (s)	Demand Flow (pcu)	Sat Flow (pcu/Hr)	Capacity (pcu)	Deg Sat (%)
Network	-	-	N/A	-	-		-	-	-	-	-	-	138.5%
A160 Humber Road / Eastfield Road	-	-	N/A	-	-		-	-	-	-	-	-	138.5%
1/1	A160 WB Ahead Left	U	N/A	N/A	B		1	35	-	536	1959	588	91.2%
1/2+1/3	A160 WB Ahead Right	U	N/A	N/A	B A		1	35:7	-	650	1966:1824	590+122	94.6 : 75.7%
2/1	Eastfield Road NB Left Ahead Right	U	N/A	N/A	C		1	21	-	209	1987	364	57.4%
3/2+3/1	A160 EB Left Ahead	U+O	N/A	N/A	E -		1	34	-	512	1956:1978	565+322	57.7 : 57.7%
3/3+3/4	A160 EB Ahead Right	U	N/A	N/A	E D		1	34:7	-	342	1950:1837	569+103	53.6 : 35.9%
4/1	Eastfield Road SB Left	U	N/A	N/A	G		1	40	-	135	1893	647	20.9%
4/2	Eastfield Road SB Right Ahead	U	N/A	N/A	F		1	30	-	690	1928	498	138.5%
5/1	A160 WB Exit	U	N/A	N/A	-		-	-	-	1859	Inf	Inf	0.0%
6/1	Eastfield Rd NB Exit	U	N/A	N/A	-		-	-	-	304	Inf	Inf	0.0%
7/1	A160 EB Exit	U	N/A	N/A	-		-	-	-	791	Inf	Inf	0.0%
8/1	Eastfield Road SB Exit	U	N/A	N/A	-		-	-	-	120	Inf	Inf	0.0%

Full Input Data And Results

Item	Arriving (pcu)	Leaving (pcu)	Turners In Gaps (pcu)	Turners When Unopposed (pcu)	Turners In Intergreen (pcu)	Uniform Delay (pcuHr)	Rand + Oversat Delay (pcuHr)	Storage Area Uniform Delay (pcuHr)	Total Delay (pcuHr)	Av. Delay Per PCU (s/pcu)	Max. Back of Uniform Queue (pcu)	Rand + Oversat Queue (pcu)	Mean Max Queue (pcu)
Network	-	-	47	140	0	46.3	108.8	0.0	155.1	-	-	-	-
A160 Humber Road / Eastfield Road	-	-	47	140	0	46.3	108.8	0.0	155.1	-	-	-	-
1/1	536	536	-	-	-	6.0	4.4	-	10.5	70.2	17.1	4.4	21.5
1/2+1/3	650	650	-	-	-	7.8	4.6	-	12.4	68.5	18.1	4.6	22.7
2/1	209	209	-	-	-	2.6	0.7	-	3.3	56.2	6.3	0.7	7.0
3/2+3/1	512	512	47	140	0	3.3	0.7	-	4.0	27.9	9.2	0.7	9.9
3/3+3/4	342	342	-	-	-	3.6	0.5	-	4.1	43.0	8.5	0.5	9.0
4/1	135	135	-	-	-	1.1	0.1	-	1.2	31.5	3.2	0.1	3.3
4/2	690	498	-	-	-	22.0	97.7	-	119.7	624.8	35.2	97.7	133.0
5/1	1682	1682	-	-	-	0.0	0.0	-	0.0	0.0	0.0	0.0	0.0
6/1	304	304	-	-	-	0.0	0.0	-	0.0	0.0	0.0	0.0	0.0
7/1	791	791	-	-	-	0.0	0.0	-	0.0	0.0	0.0	0.0	0.0
8/1	105	105	-	-	-	0.0	0.0	-	0.0	0.0	0.0	0.0	0.0
C1			PRC for Signalled Lanes (%):		-53.9	Total Delay for Signalled Lanes (pcuHr):		155.07	Cycle Time (s): 120				
			PRC Over All Lanes (%):		-53.9	Total Delay Over All Lanes(pcuHr):		155.07					

Full Input Data And Results
Full Input Data And Results

User and Project Details

Project:	Humber Zero
Title:	Junction Modelling
Location:	Immingham
File name:	J1 A160_EastfieldRd Mitigation.lsg3x
Company:	AECOM

Network Layout Diagram

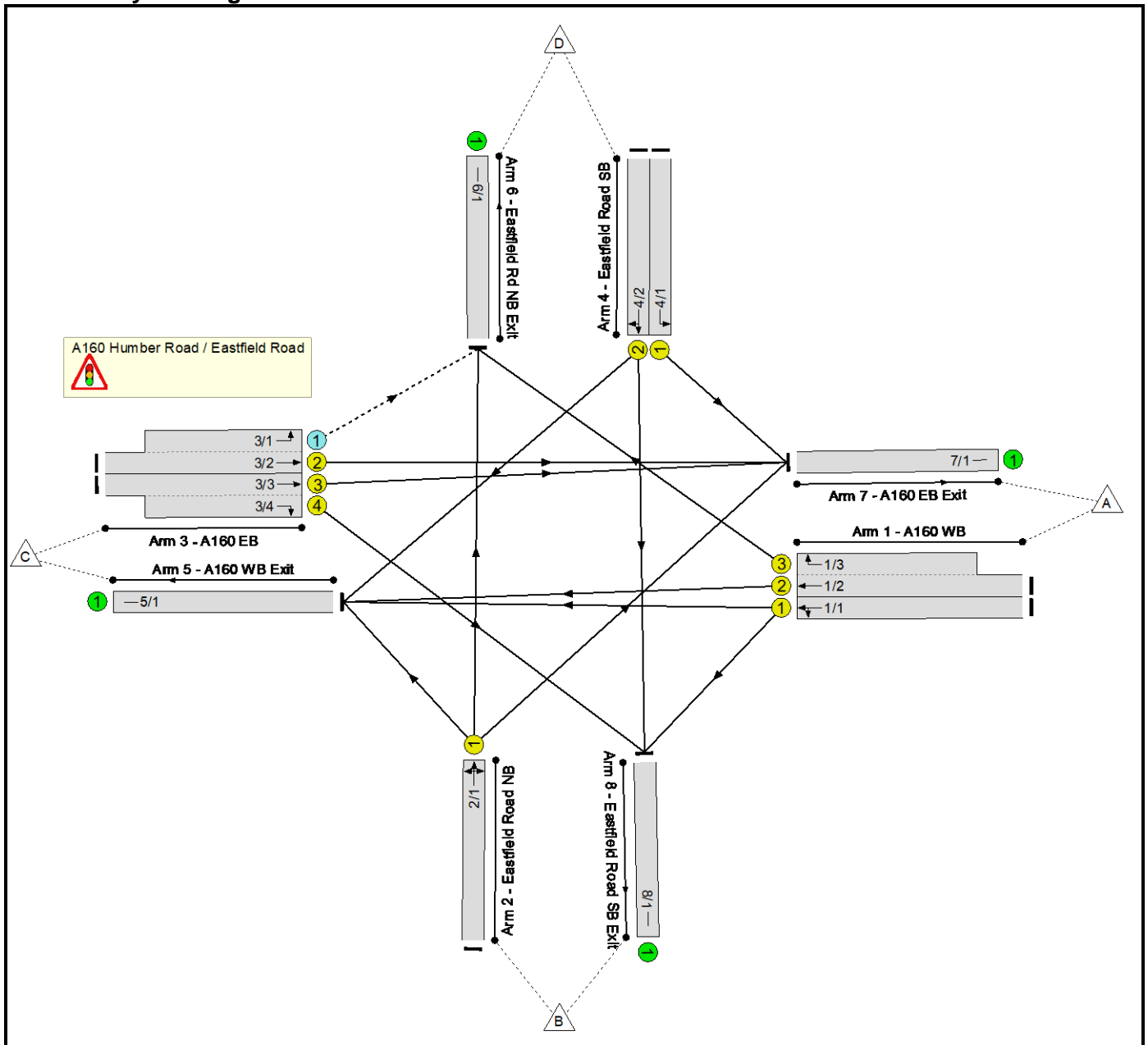

Phase Diagram

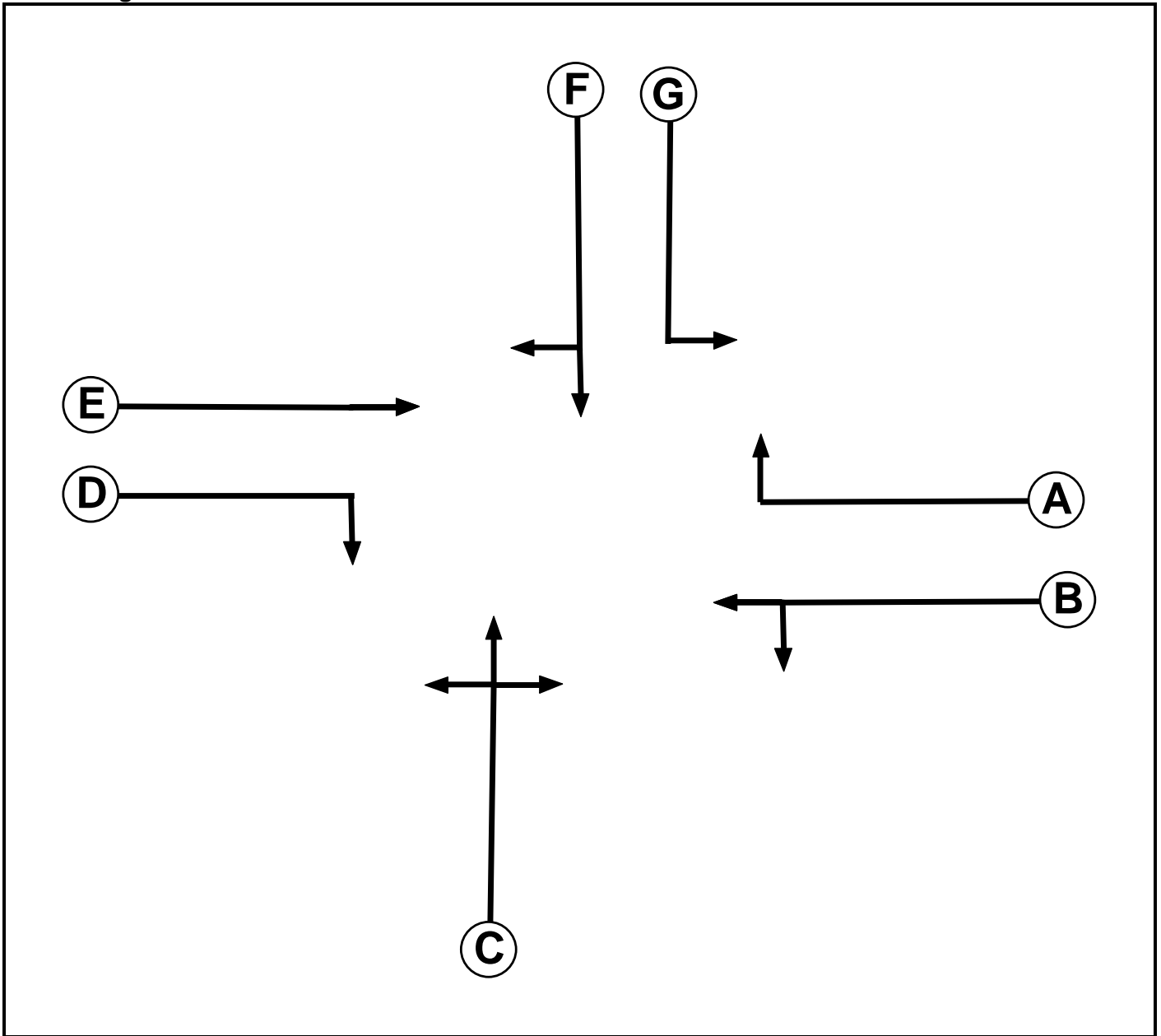

Phase Input Data

Phase Name	Phase Type	Assoc. Phase	Street Min	Cont Min
A	Traffic		7	7
B	Traffic		7	7
C	Traffic		7	7
D	Traffic		7	7
E	Traffic		7	7
F	Traffic		7	7
G	Traffic		7	7

Full Input Data And Results

Phase Intergrens Matrix

		Starting Phase						
		A	B	C	D	E	F	G
Terminating Phase	A	-	-	5	-	8	6	-
	B	-	-	8	5	-	8	-
	C	5	6	-	6	7	7	9
	D	-	7	5	-	-	6	-
	E	5	-	5	-	-	5	8
	F	5	5	7	5	5	-	-
	G	-	-	9	-	5	-	-

Phases in Stage

Stage No.	Phases in Stage
1	A D G
2	B E
3	C
4	F G

Stage Diagram

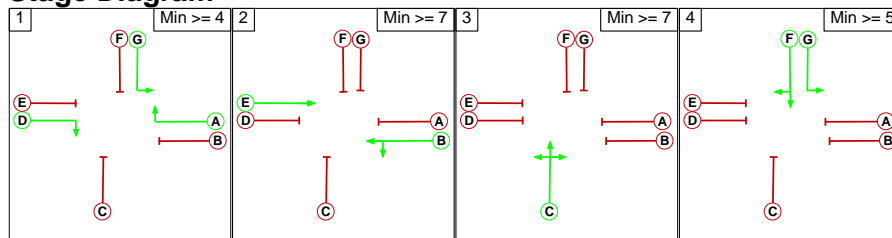

Phase Delays

Term. Stage	Start Stage	Phase	Type	Value	Cont value
There are no Phase Delays defined					

Prohibited Stage Change

		To Stage			
		1	2	3	4
From Stage	1	-	8	9	6
	2	8	-	8	8
	3	9	7	-	9
	4	5	5	9	-

Full Input Data And Results

Give-Way Lane Input Data

Junction: A160 Humber Road / Eastfield Road											
Lane	Movement	Max Flow when Giving Way (PCU/Hr)	Min Flow when Giving Way (PCU/Hr)	Opposing Lane	Opp. Lane Coeff.	Opp. Mvmnts.	Right Turn Storage (PCU)	Non-Blocking Storage (PCU)	RTF	Right Turn Move up (s)	Max Turns in Intergreen (PCU)
3/1 (A160 EB)	6/1 (Left)	1439	0	2/1	1.09	To 6/1 (Ahead)	-	-	-	-	-
				1/3	1.09	All	-	-	-	-	-

Full Input Data And Results

Lane Input Data

Junction: A160 Humber Road / Eastfield Road												
Lane	Lane Type	Phases	Start Disp.	End Disp.	Physical Length (PCU)	Sat Flow Type	Def User Saturation Flow (PCU/Hr)	Lane Width (m)	Gradient	Nearside Lane	Turns	Turning Radius (m)
1/1 (A160 WB)	U	B	2	3	129.0	Geom	-	3.51	0.00	Y	Arm 5 Ahead	Inf
											Arm 8 Left	23.56
1/2 (A160 WB)	U	B	2	3	129.0	Geom	-	3.51	0.00	Y	Arm 5 Ahead	Inf
1/3 (A160 WB)	U	A	2	3	20.0	Geom	-	3.40	0.00	Y	Arm 6 Right	20.90
2/1 (Eastfield Road NB)	U	C	2	3	60.0	Geom	-	4.50	0.00	Y	Arm 5 Left	33.50
											Arm 6 Ahead	Inf
	U		2	3	60.0	Geom	-	4.50	0.00	Y	Arm 7 Right	32.95
3/1 (A160 EB)	O		2	3	17.6	Geom	-	3.30	0.00	N	Arm 6 Left	27.80
3/2 (A160 EB)	U	E	2	3	77.2	Geom	-	3.41	0.00	Y	Arm 7 Ahead	Inf
3/3 (A160 EB)	U	E	2	3	77.2	Geom	-	3.35	0.00	Y	Arm 7 Ahead	Inf
3/4 (A160 EB)	U	D	2	3	25.7	Geom	-	3.42	0.00	Y	Arm 8 Right	23.00
4/1 (Eastfield Road SB)	U	G	2	3	11.7	Geom	-	4.20	0.00	Y	Arm 7 Left	20.00
4/2 (Eastfield Road SB)	U	F	2	3	60.0	Geom	-	4.20	0.00	Y	Arm 5 Right	25.00
											Arm 8 Ahead	Inf
5/1 (A160 WB Exit)	U		2	3	60.0	Inf	-	-	-	-	-	-
6/1 (Eastfield Rd NB Exit)	U		2	3	60.0	Inf	-	-	-	-	-	-
7/1 (A160 EB Exit)	U		2	3	60.0	Inf	-	-	-	-	-	-
8/1 (Eastfield Road SB Exit)	U		2	3	60.0	Inf	-	-	-	-	-	-

Full Input Data And Results

Traffic Flow Groups

Flow Group	Start Time	End Time	Duration	Formula
1: 'AM 2025 Base'	07:00	08:00	01:00	
2: 'PM 2025 Base'	16:00	17:00	01:00	
3: 'AM 2025 Base + Committed'	07:00	08:00	01:00	
4: 'PM 2025 Base + Committed'	16:00	17:00	01:00	
5: 'AM 2025 Base + Committed + Proposed'	07:00	08:00	01:00	
6: 'PM 2025 Base + Committed + Proposed'	16:00	17:00	01:00	

Scenario 1: 'PM 2025 Base + Committed + Propsoed' (FG6: 'PM 2025 Base + Committed + Proposed', Plan 1: 'Network Control Plan 1')

Traffic Flows, Desired

Desired Flow :

		Destination				
		A	B	C	D	Tot.
Origin	A	0	29	1065	92	1186
	B	25	0	158	26	209
	C	631	37	0	186	854
	D	135	54	636	0	825
	Tot.	791	120	1859	304	3074

Full Input Data And Results

Traffic Lane Flows

Lane	Scenario 1: PM 2025 Base + Committed + Propsoed
Junction: A160 Humber Road / Eastfield Road	
1/1	535
1/2 (with short)	651(In) 559(Out)
1/3 (short)	92
2/1	209
3/1 (short)	186
3/2 (with short)	515(In) 329(Out)
3/3 (with short)	339(In) 302(Out)
3/4 (short)	37
4/1	135
4/2	690
5/1	1859
6/1	304
7/1	791
8/1	120

Lane Saturation Flows

Junction: A160 Humber Road / Eastfield Road								
Lane	Lane Width (m)	Gradient	Nearside Lane	Allowed Turns	Turning Radius (m)	Turning Prop.	Sat Flow (PCU/Hr)	Flared Sat Flow (PCU/Hr)
1/1 (A160 WB)	3.51	0.00	Y	Arm 5 Ahead Arm 8 Left	Inf 23.56	94.6 % 5.4 %	1959	1959
1/2 (A160 WB)	3.51	0.00	Y	Arm 5 Ahead	Inf	100.0 %	1966	1966
1/3 (A160 WB)	3.40	0.00	Y	Arm 6 Right	20.90	100.0 %	1824	1824
2/1 (Eastfield Road NB)	4.50	0.00	Y	Arm 5 Left Arm 6 Ahead Arm 7 Right	33.50 Inf 32.95	75.6 % 12.4 % 12.0 %	1987	1987
3/1 (A160 EB)	3.30	0.00	N	Arm 6 Left	27.80	100.0 %	1978	1978
3/2 (A160 EB)	3.41	0.00	Y	Arm 7 Ahead	Inf	100.0 %	1956	1956
3/3 (A160 EB)	3.35	0.00	Y	Arm 7 Ahead	Inf	100.0 %	1950	1950
3/4 (A160 EB)	3.42	0.00	Y	Arm 8 Right	23.00	100.0 %	1837	1837
4/1 (Eastfield Road SB)	4.20	0.00	Y	Arm 7 Left	20.00	100.0 %	1893	1893
4/2 (Eastfield Road SB)	4.20	0.00	Y	Arm 5 Right Arm 8 Ahead	25.00 Inf	92.2 % 7.8 %	1928	1928
5/1 (A160 WB Exit Lane 1)	Infinite Saturation Flow						Inf	Inf
6/1 (Eastfield Rd NB Exit Lane 1)	Infinite Saturation Flow						Inf	Inf
7/1 (A160 EB Exit Lane 1)	Infinite Saturation Flow						Inf	Inf
8/1 (Eastfield Road SB Exit Lane 1)	Infinite Saturation Flow						Inf	Inf

Scenario 1: 'PM 2025 Base + Committed + Propsoed' (FG6: 'PM 2025 Base + Committed + Proposed', Plan 1: 'Network Control Plan 1')

Stage Sequence Diagram

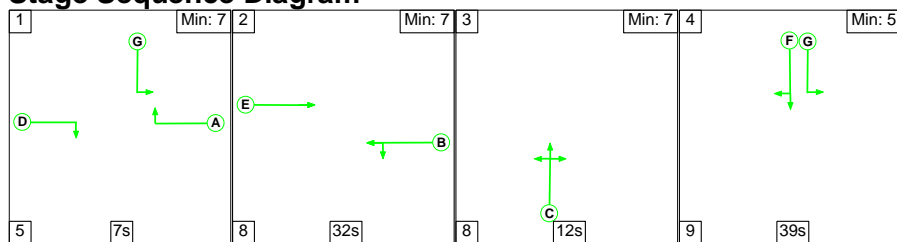

Full Input Data And Results

Stage Timings

Stage	1	2	3	4
Duration	7	32	12	39
Change Point	0	12	52	72

Signal Timings Diagram

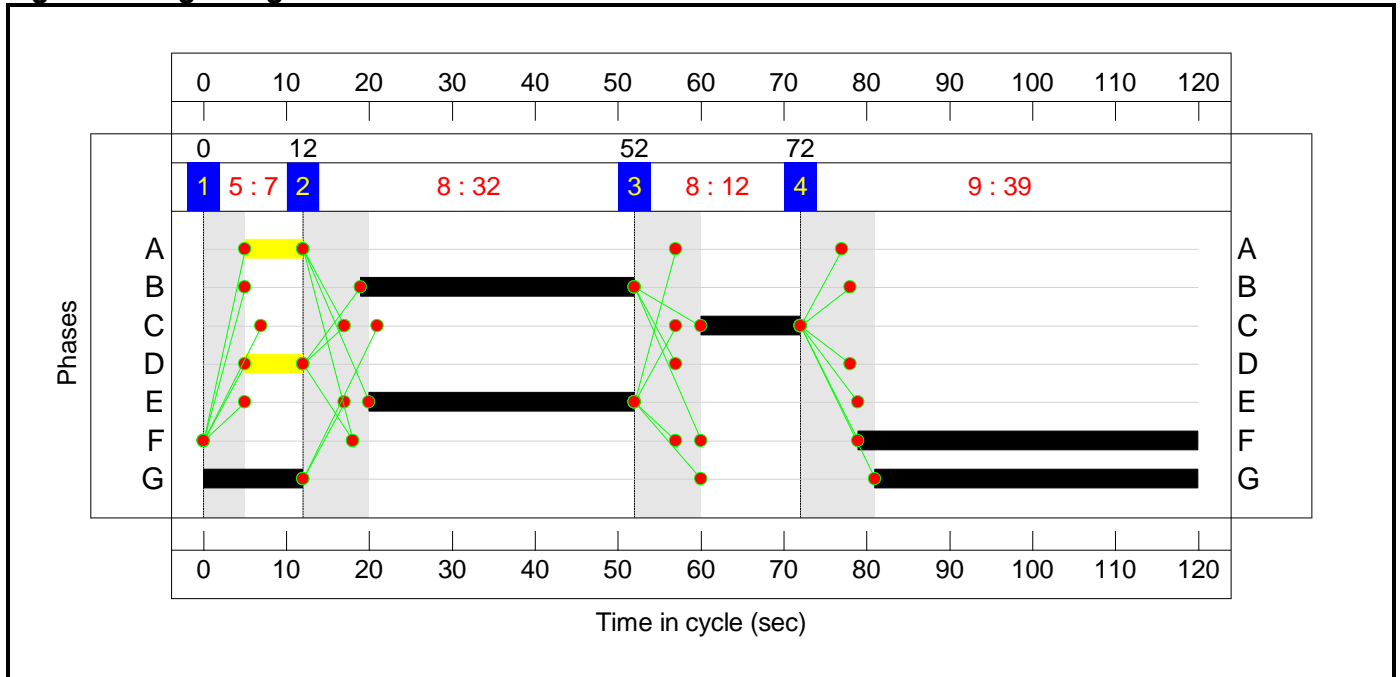

Full Input Data And Results
Network Layout Diagram

Full Input Data And Results

Network Results

Item	Lane Description	Lane Type	Controller Stream	Position In Filtered Route	Full Phase	Arrow Phase	Num Greens	Total Green (s)	Arrow Green (s)	Demand Flow (pcu)	Sat Flow (pcu/Hr)	Capacity (pcu)	Deg Sat (%)
Network	-	-	N/A	-	-		-	-	-	-	-	-	102.3%
A160 Humber Road / Eastfield Road	-	-	N/A	-	-		-	-	-	-	-	-	102.3%
1/1	A160 WB Ahead Left	U	N/A	N/A	B		1	33	-	535	1959	555	96.4%
1/2+1/3	A160 WB Ahead Right	U	N/A	N/A	B A		1	33:7	-	651	1966:1824	557+122	100.4 : 75.7%
2/1	Eastfield Road NB Left Ahead Right	U	N/A	N/A	C		1	12	-	209	1987	215	97.1%
3/2+3/1	A160 EB Left Ahead	U+O	N/A	N/A	E -		1	32	-	515	1956:1978	538+304	61.2 : 61.2%
3/3+3/4	A160 EB Ahead Right	U	N/A	N/A	E D		1	32:7	-	339	1950:1837	536+98	56.3 : 37.9%
4/1	Eastfield Road SB Left	U	N/A	N/A	G		1	51	-	135	1893	820	16.5%
4/2	Eastfield Road SB Right Ahead	U	N/A	N/A	F		1	41	-	690	1928	675	102.3%
5/1	A160 WB Exit	U	N/A	N/A	-		-	-	-	1859	Inf	Inf	0.0%
6/1	Eastfield Rd NB Exit	U	N/A	N/A	-		-	-	-	304	Inf	Inf	0.0%
7/1	A160 EB Exit	U	N/A	N/A	-		-	-	-	791	Inf	Inf	0.0%
8/1	Eastfield Road SB Exit	U	N/A	N/A	-		-	-	-	120	Inf	Inf	0.0%

Full Input Data And Results

Item	Arriving (pcu)	Leaving (pcu)	Turners In Gaps (pcu)	Turners When Unopposed (pcu)	Turners In Intergreen (pcu)	Uniform Delay (pcuHr)	Rand + Oversat Delay (pcuHr)	Storage Area Uniform Delay (pcuHr)	Total Delay (pcuHr)	Av. Delay Per PCU (s/pcu)	Max. Back of Uniform Queue (pcu)	Rand + Oversat Queue (pcu)	Mean Max Queue (pcu)
Network	-	-	33	153	0	34.1	40.9	0.0	75.0	-	-	-	-
A160 Humber Road / Eastfield Road	-	-	33	153	0	34.1	40.9	0.0	75.0	-	-	-	-
1/1	535	535	-	-	-	6.3	7.6	-	13.9	93.5	17.5	7.6	25.1
1/2+1/3	651	649	-	-	-	8.2	8.6	-	16.8	92.8	18.7	8.6	27.3
2/1	209	209	-	-	-	3.1	5.8	-	8.9	153.8	6.9	5.8	12.7
3/2+3/1	515	515	33	153	0	3.5	0.8	-	4.3	29.8	9.5	0.8	10.3
3/3+3/4	339	339	-	-	-	3.7	0.6	-	4.3	45.2	8.6	0.6	9.1
4/1	135	135	-	-	-	0.8	0.1	-	0.9	23.4	2.7	0.1	2.8
4/2	690	675	-	-	-	8.6	17.5	-	26.0	135.9	23.5	17.5	41.0
5/1	1843	1843	-	-	-	0.0	0.0	-	0.0	0.0	0.0	0.0	0.0
6/1	304	304	-	-	-	0.0	0.0	-	0.0	0.0	0.0	0.0	0.0
7/1	791	791	-	-	-	0.0	0.0	-	0.0	0.0	0.0	0.0	0.0
8/1	119	119	-	-	-	0.0	0.0	-	0.0	0.0	0.0	0.0	0.0
C1			PRC for Signalled Lanes (%):	-13.6	Total Delay for Signalled Lanes (pcuHr):			75.02	Cycle Time (s): 120				
			PRC Over All Lanes (%):	-13.6	Total Delay Over All Lanes (pcuHr):			75.02					

Junctions 10
ARCADY 10 - Roundabout Module
Version: 10.0.4.1693 © Copyright TRL Software Limited, 2021
For sales and distribution information, program advice and maintenance, contact TRL Software: +44 (0)1344 379777 software@trl.co.uk trlsoftware.com
The users of this computer program for the solution of an engineering problem are in no way relieved of their responsibility for the correctness of the solution

Filename: J2 A1061_HabroughRd_UlcebyRd_EHaltonRd.j10
Path: \\na.aecomnet.com\lfs\EMEA\Leeds-UKLDS2\Legacy\UKLDS2PFPSW001\WIP\LE_Projects\Newproje\60668866 - Humber Zero\400_Technical\Traffic & Transport\NH Comments 10.01.24\Junction Modelling\Modelling May 2024
Report generation date: 10/05/2024 07:19:33

- »2025, AM
- »2025, PM
- »2025 + Committed, AM
- »2025 + Committed, PM
- »2025 + Committed + Proposed, AM
- »2025 + Committed + Proposed, PM

Summary of junction performance

	AM					PM				
	Set ID	Queue (PCU)	Delay (s)	RFC	LOS	Set ID	Queue (PCU)	Delay (s)	RFC	LOS
2025										
Arm 1	D1	0.4	2.56	0.19	A	D2	0.9	2.70	0.41	A
Arm 2		0.3	2.88	0.21	A		0.1	3.34	0.11	A
Arm 3		1.0	2.55	0.46	A		0.4	2.24	0.23	A
Arm 4		0.3	5.74	0.20	A		0.1	3.23	0.07	A
Arm 5		0.4	4.78	0.22	A		0.3	2.78	0.23	A
2025 + Committed										
Arm 1	D3	0.4	2.60	0.20	A	D4	1.3	3.22	0.50	A
Arm 2		0.3	2.96	0.22	A		0.2	4.20	0.13	A
Arm 3		1.5	3.07	0.55	A		0.5	2.33	0.25	A
Arm 4		0.5	8.14	0.26	A		0.1	3.35	0.08	A
Arm 5		0.5	6.40	0.28	A		0.3	2.89	0.24	A
2025 + Committed + Proposed										
Arm 1	D5	0.4	2.60	0.20	A	D6	1.8	3.90	0.59	A
Arm 2		0.3	2.96	0.22	A		0.2	5.50	0.17	A
Arm 3		2.0	3.71	0.63	A		0.5	2.34	0.25	A
Arm 4		0.7	12.39	0.35	B		0.1	3.37	0.08	A
Arm 5		0.7	8.83	0.35	A		0.3	2.90	0.24	A

Values shown are the highest values encountered over all time segments. Delay is the maximum value of average delay per arriving vehicle.

File summary

File Description

Title	
Location	
Site number	
Date	17/01/2024
Version	
Status	(new file)
Identifier	
Client	
Jobnumber	
Enumerator	NA\SimmonsA1
Description	

Units

Distance units	Speed units	Traffic units input	Traffic units results	Flow units	Average delay units	Total delay units	Rate of delay units
m	kph	PCU	PCU	perHour	s	-Min	perMin



Flows show original traffic demand (PCU/hr).

The junction diagram reflects the last run of Junctions.

Analysis Options

Calculate Queue Percentiles	Calculate residual capacity	RFC Threshold	Average Delay threshold (s)	Queue threshold (PCU)
		0.85	36.00	20.00

Demand Set Summary

ID	Scenario name	Time Period name	Traffic profile type	Start time (HH:mm)	Finish time (HH:mm)	Time segment length (min)
D1	2025	AM	ONE HOUR	06:45	08:15	15
D2	2025	PM	ONE HOUR	15:45	17:15	15
D3	2025 + Committed	AM	ONE HOUR	06:45	08:15	15
D4	2025 + Committed	PM	ONE HOUR	15:45	17:15	15
D5	2025 + Committed + Proposed	AM	ONE HOUR	06:45	08:15	15
D6	2025 + Committed + Proposed	PM	ONE HOUR	15:45	17:15	15

Analysis Set Details

ID	Network flow scaling factor (%)
A1	100.000

2025, AM

Data Errors and Warnings

No errors or warnings

Junction Network

Junctions

Junction	Name	Junction type	Use circulating lanes	Arm order	Junction Delay (s)	Junction LOS
1	untitled	Standard Roundabout		1, 2, 3, 4, 5	3.03	A

Junction Network

Driving side	Lighting	Network delay (s)	Network LOS
Left	Normal/unknown	3.03	A

Arms

Arms

Arm	Name	Description	No give-way line
1	A160 East		
2	Harbrough Road		
3	A160 West		
4	Ulceby Road		
5	East Halton Road		

Roundabout Geometry

Arm	V - Approach road half-width (m)	E - Entry width (m)	I' - Effective flare length (m)	R - Entry radius (m)	D - Inscribed circle diameter (m)	PHI - Conflict (entry) angle (deg)	Entry only	Exit only
1	7.79	9.26	20.0	50.7	100.0	35.0		
2	3.89	6.91	13.7	15.1	100.0	51.0		
3	7.28	9.43	15.0	36.0	100.0	38.0		
4	3.91	6.92	10.3	32.9	100.0	35.0		
5	3.68	7.53	12.6	27.2	100.0	38.0		

Slope / Intercept / Capacity

Roundabout Slope and Intercept used in model

Arm	Enter slope and intercept directly	Entered slope	Entered intercept (PCU/hr)	Final slope	Final intercept (PCU/hr)
1	✓	1.250	3529	1.250	3529
2	✓	0.824	2336	0.824	2336
3	✓	1.232	3486	1.232	3486
4	✓	0.815	2337	0.815	2337
5	✓	0.826	2365	0.826	2365

The slope and intercept shown above include any corrections and adjustments.

Traffic Demand

Demand Set Details

ID	Scenario name	Time Period name	Traffic profile type	Start time (HH:mm)	Finish time (HH:mm)	Time segment length (min)
D1	2025	AM	ONE HOUR	06:45	08:15	15

Vehicle mix source	PCU Factor for a HV (PCU)
HV Percentages	2.00

Demand overview (Traffic)

Arm	Linked arm	Use O-D data	Average Demand (PCU/hr)	Scaling Factor (%)
1		✓	529	100.000
2		✓	324	100.000
3		✓	1320	100.000
4		✓	180	100.000
5		✓	252	100.000

Origin-Destination Data

Demand (PCU/hr)

		To				
		1	2	3	4	5
From	1	0	17	439	39	34
	2	53	0	151	3	117
	3	986	40	0	37	257
	4	82	8	70	0	20
	5	48	44	151	9	0

Vehicle Mix

Heavy Vehicle Percentages

		To				
		1	2	3	4	5
From	1	100	69	82	62	55
	2	1	0	6	33	4
	3	21	3	0	49	13
	4	35	13	22	0	32
	5	39	7	32	22	0

Detailed Demand Data

Demand for each time segment

Time Segment	Arm	Demand (PCU/hr)	Demand in PCU (PCU/hr)
06:45-07:00	1	398	398
	2	244	244
	3	994	994
	4	136	136
	5	190	190
07:00-07:15	1	476	476
	2	291	291
	3	1187	1187
	4	162	162
	5	227	227
07:15-07:30	1	582	582
	2	357	357
	3	1453	1453
	4	198	198
	5	277	277
07:30-07:45	1	582	582
	2	357	357
	3	1453	1453
	4	198	198
	5	277	277
07:45-08:00	1	476	476
	2	291	291
	3	1187	1187
	4	162	162
	5	227	227
08:00-08:15	1	398	398
	2	244	244
	3	994	994
	4	136	136
	5	190	190

Results

Results Summary for whole modelled period

Arm	Max RFC	Max Delay (s)	Max Queue (PCU)	Max LOS
1	0.19	2.56	0.4	A
2	0.21	2.88	0.3	A
3	0.46	2.55	1.0	A
4	0.20	5.74	0.3	A
5	0.22	4.78	0.4	A

Main Results for each time segment

06:45 - 07:00

Arm	Total Demand (PCU/hr)	Circulating flow (PCU/hr)	Capacity (PCU/hr)	RFC	Throughput (PCU/hr)	End queue (PCU)	Delay (s)	Unsignalised level of service
1	398	242	3227	0.123	397	0.2	2.264	A
2	244	557	1877	0.130	243	0.2	2.305	A
3	994	191	3250	0.306	992	0.5	1.900	A
4	136	1117	1427	0.095	135	0.1	3.572	A
5	190	931	1596	0.119	189	0.2	3.263	A

07:00 - 07:15

Arm	Total Demand (PCU/hr)	Circulating flow (PCU/hr)	Capacity (PCU/hr)	RFC	Throughput (PCU/hr)	End queue (PCU)	Delay (s)	Unsignalised level of service
1	476	289	3168	0.150	475	0.3	2.379	A
2	291	667	1787	0.163	291	0.2	2.518	A
3	1187	229	3204	0.370	1186	0.7	2.129	A
4	162	1336	1248	0.130	162	0.2	4.248	A
5	227	1113	1446	0.157	226	0.2	3.768	A

07:15 - 07:30

Arm	Total Demand (PCU/hr)	Circulating flow (PCU/hr)	Capacity (PCU/hr)	RFC	Throughput (PCU/hr)	End queue (PCU)	Delay (s)	Unsignalised level of service
1	582	354	3087	0.189	582	0.4	2.557	A
2	357	816	1664	0.214	356	0.3	2.881	A
3	1453	281	3140	0.463	1452	1.0	2.544	A
4	198	1636	1004	0.197	198	0.3	5.723	A
5	277	1363	1239	0.224	277	0.4	4.772	A

07:30 - 07:45

Arm	Total Demand (PCU/hr)	Circulating flow (PCU/hr)	Capacity (PCU/hr)	RFC	Throughput (PCU/hr)	End queue (PCU)	Delay (s)	Unsignalised level of service
1	582	355	3086	0.189	582	0.4	2.558	A
2	357	817	1663	0.215	357	0.3	2.883	A
3	1453	281	3140	0.463	1453	1.0	2.546	A
4	198	1637	1003	0.198	198	0.3	5.738	A
5	277	1364	1238	0.224	277	0.4	4.782	A

07:45 - 08:00

Arm	Total Demand (PCU/hr)	Circulating flow (PCU/hr)	Capacity (PCU/hr)	RFC	Throughput (PCU/hr)	End queue (PCU)	Delay (s)	Unsignalised level of service
1	476	290	3166	0.150	476	0.3	2.382	A
2	291	668	1786	0.163	292	0.2	2.523	A
3	1187	229	3203	0.370	1188	0.7	2.134	A
4	162	1338	1246	0.130	162	0.2	4.260	A
5	227	1115	1444	0.157	227	0.2	3.777	A

08:00 - 08:15

Arm	Total Demand (PCU/hr)	Circulating flow (PCU/hr)	Capacity (PCU/hr)	RFC	Throughput (PCU/hr)	End queue (PCU)	Delay (s)	Unsignalised level of service
1	398	243	3226	0.123	399	0.3	2.267	A
2	244	559	1875	0.130	244	0.2	2.308	A
3	994	192	3249	0.306	994	0.5	1.908	A
4	136	1120	1424	0.095	136	0.1	3.583	A
5	190	934	1594	0.119	190	0.2	3.273	A

2025, PM

Data Errors and Warnings

No errors or warnings

Junction Network

Junctions

Junction	Name	Junction type	Use circulating lanes	Arm order	Junction Delay (s)	Junction LOS
1	untitled	Standard Roundabout		1, 2, 3, 4, 5	2.64	A

Junction Network

Driving side	Lighting	Network delay (s)	Network LOS
Left	Normal/unknown	2.64	A

Traffic Demand

Demand Set Details

ID	Scenario name	Time Period name	Traffic profile type	Start time (HH:mm)	Finish time (HH:mm)	Time segment length (min)
D2	2025	PM	ONE HOUR	15:45	17:15	15

Vehicle mix source	PCU Factor for a HV (PCU)
HV Percentages	2.00

Demand overview (Traffic)

Arm	Linked arm	Use O-D data	Average Demand (PCU/hr)	Scaling Factor (%)
1		✓	1063	100.000
2		✓	122	100.000
3		✓	648	100.000
4		✓	111	100.000
5		✓	391	100.000

Origin-Destination Data

Demand (PCU/hr)

		To				
		1	2	3	4	5
From	1	0	119	811	19	114
	2	18	0	41	19	44
	3	371	62	0	75	140
	4	32	15	41	0	23
	5	40	114	207	30	0

Vehicle Mix

Heavy Vehicle Percentages

		To				
		1	2	3	4	5
From	1	100	1	30	42	59
	2	6	0	0	0	2
	3	78	5	0	32	37
	4	52	7	38	0	50
	5	42	1	13	14	0

Detailed Demand Data

Demand for each time segment

Time Segment	Arm	Demand (PCU/hr)	Demand in PCU (PCU/hr)
15:45-16:00	1	800	800
	2	92	92
	3	488	488
	4	84	84
	5	294	294
16:00-16:15	1	956	956
	2	110	110
	3	583	583
	4	100	100
	5	352	352
16:15-16:30	1	1170	1170
	2	134	134
	3	713	713
	4	122	122
	5	430	430
16:30-16:45	1	1170	1170
	2	134	134
	3	713	713
	4	122	122
	5	430	430
16:45-17:00	1	956	956
	2	110	110
	3	583	583
	4	100	100
	5	352	352
17:00-17:15	1	800	800
	2	92	92
	3	488	488
	4	84	84
	5	294	294

Results

Results Summary for whole modelled period

Arm	Max RFC	Max Delay (s)	Max Queue (PCU)	Max LOS
1	0.41	2.70	0.9	A
2	0.11	3.34	0.1	A
3	0.23	2.24	0.4	A
4	0.07	3.23	0.1	A
5	0.23	2.78	0.3	A

Main Results for each time segment

15:45 - 16:00

Arm	Total Demand (PCU/hr)	Circulating flow (PCU/hr)	Capacity (PCU/hr)	RFC	Throughput (PCU/hr)	End queue (PCU)	Delay (s)	Unsignalised level of service
1	800	352	3089	0.259	798	0.4	2.021	A
2	92	918	1580	0.058	92	0.1	2.457	A
3	488	183	3260	0.150	487	0.3	1.972	A
4	84	563	1878	0.044	83	0.1	2.778	A
5	294	405	2031	0.145	294	0.2	2.310	A

16:00 - 16:15

Arm	Total Demand (PCU/hr)	Circulating flow (PCU/hr)	Capacity (PCU/hr)	RFC	Throughput (PCU/hr)	End queue (PCU)	Delay (s)	Unsignalised level of service
1	956	421	3002	0.318	955	0.6	2.261	A
2	110	1098	1431	0.077	110	0.1	2.765	A
3	583	219	3216	0.181	582	0.3	2.076	A
4	100	673	1789	0.056	100	0.1	2.952	A
5	352	484	1965	0.179	351	0.2	2.488	A

16:15 - 16:30

Arm	Total Demand (PCU/hr)	Circulating flow (PCU/hr)	Capacity (PCU/hr)	RFC	Throughput (PCU/hr)	End queue (PCU)	Delay (s)	Unsignalised level of service
1	1170	516	2884	0.406	1169	0.9	2.698	A
2	134	1344	1228	0.109	134	0.1	3.341	A
3	713	268	3155	0.226	713	0.4	2.239	A
4	122	824	1665	0.073	122	0.1	3.231	A
5	430	593	1875	0.230	430	0.3	2.779	A

16:30 - 16:45

Arm	Total Demand (PCU/hr)	Circulating flow (PCU/hr)	Capacity (PCU/hr)	RFC	Throughput (PCU/hr)	End queue (PCU)	Delay (s)	Unsignalised level of service
1	1170	516	2884	0.406	1170	0.9	2.701	A
2	134	1345	1227	0.109	134	0.1	3.344	A
3	713	269	3155	0.226	713	0.4	2.239	A
4	122	825	1665	0.073	122	0.1	3.232	A
5	430	593	1875	0.230	430	0.3	2.779	A

16:45 - 17:00

Arm	Total Demand (PCU/hr)	Circulating flow (PCU/hr)	Capacity (PCU/hr)	RFC	Throughput (PCU/hr)	End queue (PCU)	Delay (s)	Unsignalised level of service
1	956	422	3001	0.318	957	0.6	2.266	A
2	110	1100	1430	0.077	110	0.1	2.772	A
3	583	220	3215	0.181	583	0.3	2.079	A
4	100	674	1788	0.056	100	0.1	2.956	A
5	352	485	1964	0.179	352	0.2	2.492	A

17:00 - 17:15

Arm	Total Demand (PCU/hr)	Circulating flow (PCU/hr)	Capacity (PCU/hr)	RFC	Throughput (PCU/hr)	End queue (PCU)	Delay (s)	Unsignalised level of service
1	800	353	3087	0.259	801	0.5	2.026	A
2	92	921	1577	0.058	92	0.1	2.461	A
3	488	184	3260	0.150	488	0.3	1.975	A
4	84	564	1877	0.045	84	0.1	2.782	A
5	294	406	2030	0.145	295	0.2	2.316	A

2025 + Committed, AM

Data Errors and Warnings

No errors or warnings

Junction Network

Junctions

Junction	Name	Junction type	Use circulating lanes	Arm order	Junction Delay (s)	Junction LOS
1	untitled	Standard Roundabout		1, 2, 3, 4, 5	3.58	A

Junction Network

Driving side	Lighting	Network delay (s)	Network LOS
Left	Normal/unknown	3.58	A

Traffic Demand

Demand Set Details

ID	Scenario name	Time Period name	Traffic profile type	Start time (HH:mm)	Finish time (HH:mm)	Time segment length (min)
D3	2025 + Committed	AM	ONE HOUR	06:45	08:15	15

Vehicle mix source	PCU Factor for a HV (PCU)
HV Percentages	2.00

Demand overview (Traffic)

Arm	Linked arm	Use O-D data	Average Demand (PCU/hr)	Scaling Factor (%)
1		✓	557	100.000
2		✓	329	100.000
3		✓	1574	100.000
4		✓	185	100.000
5		✓	256	100.000

Origin-Destination Data

Demand (PCU/hr)

		To				
		1	2	3	4	5
From	1	0	17	467	39	34
	2	57	0	152	3	117
	3	1239	40	0	37	258
	4	86	8	71	0	20
	5	51	44	152	9	0

Vehicle Mix

Heavy Vehicle Percentages

		To				
		1	2	3	4	5
From	1	100	69	82	62	55
	2	1	0	6	33	4
	3	21	3	0	49	13
	4	35	13	22	0	32
	5	39	7	32	22	0

Detailed Demand Data

Demand for each time segment

Time Segment	Arm	Demand (PCU/hr)	Demand in PCU (PCU/hr)
06:45-07:00	1	419	419
	2	248	248
	3	1185	1185
	4	139	139
	5	193	193
07:00-07:15	1	501	501
	2	296	296
	3	1415	1415
	4	166	166
	5	230	230
07:15-07:30	1	613	613
	2	362	362
	3	1733	1733
	4	204	204
	5	282	282
07:30-07:45	1	613	613
	2	362	362
	3	1733	1733
	4	204	204
	5	282	282
07:45-08:00	1	501	501
	2	296	296
	3	1415	1415
	4	166	166
	5	230	230
08:00-08:15	1	419	419
	2	248	248
	3	1185	1185
	4	139	139
	5	193	193

Results

Results Summary for whole modelled period

Arm	Max RFC	Max Delay (s)	Max Queue (PCU)	Max LOS
1	0.20	2.60	0.4	A
2	0.22	2.96	0.3	A
3	0.55	3.07	1.5	A
4	0.26	8.14	0.5	A
5	0.28	6.40	0.5	A

Main Results for each time segment

06:45 - 07:00

Arm	Total Demand (PCU/hr)	Circulating flow (PCU/hr)	Capacity (PCU/hr)	RFC	Throughput (PCU/hr)	End queue (PCU)	Delay (s)	Unsignalised level of service
1	419	243	3225	0.130	418	0.3	2.285	A
2	248	579	1859	0.133	247	0.2	2.334	A
3	1185	194	3246	0.365	1182	0.7	2.083	A
4	139	1311	1269	0.110	139	0.2	4.087	A
5	193	1127	1434	0.134	192	0.2	3.702	A

07:00 - 07:15

Arm	Total Demand (PCU/hr)	Circulating flow (PCU/hr)	Capacity (PCU/hr)	RFC	Throughput (PCU/hr)	End queue (PCU)	Delay (s)	Unsignalised level of service
1	501	291	3165	0.158	500	0.3	2.406	A
2	296	693	1765	0.168	296	0.2	2.562	A
3	1415	233	3199	0.442	1414	0.9	2.410	A
4	166	1568	1059	0.157	166	0.2	5.171	A
5	230	1348	1251	0.184	230	0.3	4.502	A

07:15 - 07:30

Arm	Total Demand (PCU/hr)	Circulating flow (PCU/hr)	Capacity (PCU/hr)	RFC	Throughput (PCU/hr)	End queue (PCU)	Delay (s)	Unsignalised level of service
1	613	356	3084	0.199	613	0.4	2.594	A
2	362	849	1637	0.221	362	0.3	2.953	A
3	1733	285	3135	0.553	1731	1.5	3.063	A
4	204	1919	773	0.264	203	0.5	8.092	A
5	282	1650	1002	0.281	281	0.5	6.374	A

07:30 - 07:45

Arm	Total Demand (PCU/hr)	Circulating flow (PCU/hr)	Capacity (PCU/hr)	RFC	Throughput (PCU/hr)	End queue (PCU)	Delay (s)	Unsignalised level of service
1	613	357	3083	0.199	613	0.4	2.596	A
2	362	850	1636	0.221	362	0.3	2.955	A
3	1733	285	3135	0.553	1733	1.5	3.071	A
4	204	1921	771	0.264	204	0.5	8.142	A
5	282	1653	1000	0.282	282	0.5	6.405	A

07:45 - 08:00

Arm	Total Demand (PCU/hr)	Circulating flow (PCU/hr)	Capacity (PCU/hr)	RFC	Throughput (PCU/hr)	End queue (PCU)	Delay (s)	Unsignalised level of service
1	501	292	3164	0.158	501	0.3	2.408	A
2	296	695	1763	0.168	296	0.2	2.568	A
3	1415	233	3199	0.442	1417	1.0	2.420	A
4	166	1571	1057	0.157	167	0.2	5.201	A
5	230	1352	1248	0.184	231	0.3	4.524	A

08:00 - 08:15

Arm	Total Demand (PCU/hr)	Circulating flow (PCU/hr)	Capacity (PCU/hr)	RFC	Throughput (PCU/hr)	End queue (PCU)	Delay (s)	Unsignalised level of service
1	419	244	3224	0.130	420	0.3	2.288	A
2	248	582	1857	0.133	248	0.2	2.340	A
3	1185	195	3246	0.365	1186	0.7	2.093	A
4	139	1315	1265	0.110	140	0.2	4.107	A
5	193	1131	1431	0.135	193	0.2	3.720	A

2025 + Committed, PM

Data Errors and Warnings

No errors or warnings

Junction Network

Junctions

Junction	Name	Junction type	Use circulating lanes	Arm order	Junction Delay (s)	Junction LOS
1	untitled	Standard Roundabout		1, 2, 3, 4, 5	2.98	A

Junction Network

Driving side	Lighting	Network delay (s)	Network LOS
Left	Normal/unknown	2.98	A

Traffic Demand

Demand Set Details

ID	Scenario name	Time Period name	Traffic profile type	Start time (HH:mm)	Finish time (HH:mm)	Time segment length (min)
D4	2025 + Committed	PM	ONE HOUR	15:45	17:15	15

Vehicle mix source	PCU Factor for a HV (PCU)
HV Percentages	2.00

Demand overview (Traffic)

Arm	Linked arm	Use O-D data	Average Demand (PCU/hr)	Scaling Factor (%)
1		✓	1308	100.000
2		✓	122	100.000
3		✓	712	100.000
4		✓	111	100.000
5		✓	391	100.000

Origin-Destination Data

Demand (PCU/hr)

		To				
		1	2	3	4	5
From	1	0	119	1056	19	114
	2	18	0	41	19	44
	3	431	64	0	76	141
	4	32	15	41	0	23
	5	40	114	207	30	0

Vehicle Mix

Heavy Vehicle Percentages

	To					
	1	2	3	4	5	
From	1	100	1	30	42	59
	2	6	0	0	0	2
	3	78	5	0	32	37
	4	52	7	38	0	50
	5	42	1	13	14	0

Detailed Demand Data

Demand for each time segment

Time Segment	Arm	Demand (PCU/hr)	Demand in PCU (PCU/hr)
15:45-16:00	1	985	985
	2	92	92
	3	536	536
	4	84	84
	5	294	294
16:00-16:15	1	1176	1176
	2	110	110
	3	640	640
	4	100	100
	5	352	352
16:15-16:30	1	1440	1440
	2	134	134
	3	784	784
	4	122	122
	5	430	430
16:30-16:45	1	1440	1440
	2	134	134
	3	784	784
	4	122	122
	5	430	430
16:45-17:00	1	1176	1176
	2	110	110
	3	640	640
	4	100	100
	5	352	352
17:00-17:15	1	985	985
	2	92	92
	3	536	536
	4	84	84
	5	294	294

Results

Results Summary for whole modelled period

Arm	Max RFC	Max Delay (s)	Max Queue (PCU)	Max LOS
1	0.50	3.22	1.3	A
2	0.13	4.20	0.2	A
3	0.25	2.33	0.5	A
4	0.08	3.35	0.1	A
5	0.24	2.89	0.3	A

Main Results for each time segment

15:45 - 16:00

Arm	Total Demand (PCU/hr)	Circulating flow (PCU/hr)	Capacity (PCU/hr)	RFC	Throughput (PCU/hr)	End queue (PCU)	Delay (s)	Unsignalised level of service
1	985	354	3087	0.319	982	0.6	2.202	A
2	92	1102	1428	0.064	92	0.1	2.735	A
3	536	183	3260	0.164	535	0.3	2.027	A
4	84	610	1840	0.045	83	0.1	2.839	A
5	294	451	1992	0.148	294	0.2	2.362	A

16:00 - 16:15

Arm	Total Demand (PCU/hr)	Circulating flow (PCU/hr)	Capacity (PCU/hr)	RFC	Throughput (PCU/hr)	End queue (PCU)	Delay (s)	Unsignalised level of service
1	1176	423	3000	0.392	1175	0.8	2.540	A
2	110	1318	1250	0.088	110	0.1	3.205	A
3	640	219	3216	0.199	640	0.4	2.146	A
4	100	730	1742	0.057	100	0.1	3.035	A
5	352	540	1919	0.183	351	0.2	2.561	A

16:15 - 16:30

Arm	Total Demand (PCU/hr)	Circulating flow (PCU/hr)	Capacity (PCU/hr)	RFC	Throughput (PCU/hr)	End queue (PCU)	Delay (s)	Unsignalised level of service
1	1440	518	2881	0.500	1438	1.3	3.210	A
2	134	1613	1007	0.133	134	0.2	4.189	A
3	784	268	3155	0.248	783	0.5	2.331	A
4	122	893	1609	0.076	122	0.1	3.354	A
5	430	661	1819	0.237	430	0.3	2.891	A

16:30 - 16:45

Arm	Total Demand (PCU/hr)	Circulating flow (PCU/hr)	Capacity (PCU/hr)	RFC	Throughput (PCU/hr)	End queue (PCU)	Delay (s)	Unsignalised level of service
1	1440	519	2881	0.500	1440	1.3	3.218	A
2	134	1615	1005	0.134	134	0.2	4.198	A
3	784	269	3155	0.248	784	0.5	2.331	A
4	122	894	1608	0.076	122	0.1	3.355	A
5	430	662	1818	0.237	430	0.3	2.892	A

16:45 - 17:00

Arm	Total Demand (PCU/hr)	Circulating flow (PCU/hr)	Capacity (PCU/hr)	RFC	Throughput (PCU/hr)	End queue (PCU)	Delay (s)	Unsignalised level of service
1	1176	424	2999	0.392	1178	0.8	2.548	A
2	110	1321	1248	0.088	110	0.1	3.213	A
3	640	220	3215	0.199	641	0.4	2.149	A
4	100	731	1741	0.057	100	0.1	3.037	A
5	352	541	1918	0.183	352	0.3	2.563	A

17:00 - 17:15

Arm	Total Demand (PCU/hr)	Circulating flow (PCU/hr)	Capacity (PCU/hr)	RFC	Throughput (PCU/hr)	End queue (PCU)	Delay (s)	Unsignalised level of service
1	985	355	3085	0.319	986	0.6	2.209	A
2	92	1105	1425	0.064	92	0.1	2.744	A
3	536	184	3259	0.164	536	0.3	2.031	A
4	84	612	1838	0.045	84	0.1	2.844	A
5	294	453	1991	0.148	295	0.2	2.368	A

2025 + Committed + Proposed, AM

Data Errors and Warnings

No errors or warnings

Junction Network

Junctions

Junction	Name	Junction type	Use circulating lanes	Arm order	Junction Delay (s)	Junction LOS
1	untitled	Standard Roundabout		1, 2, 3, 4, 5	4.36	A

Junction Network

Driving side	Lighting	Network delay (s)	Network LOS
Left	Normal/unknown	4.36	A

Traffic Demand

Demand Set Details

ID	Scenario name	Time Period name	Traffic profile type	Start time (HH:mm)	Finish time (HH:mm)	Time segment length (min)
D5	2025 + Committed + Proposed	AM	ONE HOUR	06:45	08:15	15

Vehicle mix source	PCU Factor for a HV (PCU)
HV Percentages	2.00

Demand overview (Traffic)

Arm	Linked arm	Use O-D data	Average Demand (PCU/hr)	Scaling Factor (%)
1		✓	558	100.000
2		✓	329	100.000
3		✓	1791	100.000
4		✓	185	100.000
5		✓	256	100.000

Origin-Destination Data

Demand (PCU/hr)

		To				
		1	2	3	4	5
From	1	0	17	468	39	34
	2	57	0	152	3	117
	3	1454	42	0	37	258
	4	86	8	71	0	20
	5	51	44	152	9	0

Vehicle Mix

Heavy Vehicle Percentages

		To				
From		1	2	3	4	5
	1	100	69	82	62	55
	2	1	0	6	33	4
	3	21	3	0	49	13
	4	35	13	22	0	32
	5	39	7	32	22	0

Detailed Demand Data

Demand for each time segment

Time Segment	Arm	Demand (PCU/hr)	Demand in PCU (PCU/hr)
06:45-07:00	1	420	420
	2	248	248
	3	1348	1348
	4	139	139
	5	193	193
07:00-07:15	1	502	502
	2	296	296
	3	1610	1610
	4	166	166
	5	230	230
07:15-07:30	1	614	614
	2	362	362
	3	1972	1972
	4	204	204
	5	282	282
07:30-07:45	1	614	614
	2	362	362
	3	1972	1972
	4	204	204
	5	282	282
07:45-08:00	1	502	502
	2	296	296
	3	1610	1610
	4	166	166
	5	230	230
08:00-08:15	1	420	420
	2	248	248
	3	1348	1348
	4	139	139
	5	193	193

Results

Results Summary for whole modelled period

Arm	Max RFC	Max Delay (s)	Max Queue (PCU)	Max LOS
1	0.20	2.60	0.4	A
2	0.22	2.96	0.3	A
3	0.63	3.71	2.0	A
4	0.35	12.39	0.7	B
5	0.35	8.83	0.7	A

Main Results for each time segment

06:45 - 07:00

Arm	Total Demand (PCU/hr)	Circulating flow (PCU/hr)	Capacity (PCU/hr)	RFC	Throughput (PCU/hr)	End queue (PCU)	Delay (s)	Unsignalised level of service
1	420	244	3224	0.130	419	0.3	2.287	A
2	248	580	1858	0.133	247	0.2	2.335	A
3	1348	194	3246	0.415	1345	0.8	2.263	A
4	139	1473	1136	0.123	139	0.2	4.629	A
5	193	1290	1300	0.148	192	0.2	4.149	A

07:00 - 07:15

Arm	Total Demand (PCU/hr)	Circulating flow (PCU/hr)	Capacity (PCU/hr)	RFC	Throughput (PCU/hr)	End queue (PCU)	Delay (s)	Unsignalised level of service
1	502	292	3163	0.159	501	0.3	2.409	A
2	296	694	1764	0.168	296	0.2	2.563	A
3	1610	233	3199	0.503	1609	1.2	2.707	A
4	166	1762	901	0.185	166	0.3	6.283	A
5	230	1543	1091	0.211	230	0.3	5.341	A

07:15 - 07:30

Arm	Total Demand (PCU/hr)	Circulating flow (PCU/hr)	Capacity (PCU/hr)	RFC	Throughput (PCU/hr)	End queue (PCU)	Delay (s)	Unsignalised level of service
1	614	357	3083	0.199	614	0.4	2.597	A
2	362	849	1636	0.221	362	0.3	2.954	A
3	1972	285	3135	0.629	1969	2.0	3.685	A
4	204	2157	579	0.352	202	0.7	12.204	B
5	282	1887	806	0.350	281	0.7	8.731	A

07:30 - 07:45

Arm	Total Demand (PCU/hr)	Circulating flow (PCU/hr)	Capacity (PCU/hr)	RFC	Throughput (PCU/hr)	End queue (PCU)	Delay (s)	Unsignalised level of service
1	614	359	3080	0.199	614	0.4	2.600	A
2	362	851	1635	0.222	362	0.3	2.958	A
3	1972	285	3135	0.629	1972	2.0	3.706	A
4	204	2160	576	0.353	204	0.7	12.388	B
5	282	1891	803	0.351	282	0.7	8.831	A

07:45 - 08:00

Arm	Total Demand (PCU/hr)	Circulating flow (PCU/hr)	Capacity (PCU/hr)	RFC	Throughput (PCU/hr)	End queue (PCU)	Delay (s)	Unsignalised level of service
1	502	295	3160	0.159	502	0.3	2.412	A
2	296	697	1762	0.168	296	0.2	2.568	A
3	1610	233	3199	0.503	1613	1.2	2.726	A
4	166	1767	897	0.185	168	0.3	6.352	A
5	230	1549	1086	0.212	231	0.3	5.394	A

08:00 - 08:15

Arm	Total Demand (PCU/hr)	Circulating flow (PCU/hr)	Capacity (PCU/hr)	RFC	Throughput (PCU/hr)	End queue (PCU)	Delay (s)	Unsignalised level of service
1	420	246	3221	0.130	420	0.3	2.289	A
2	248	583	1856	0.133	248	0.2	2.341	A
3	1348	195	3246	0.415	1350	0.9	2.277	A
4	139	1479	1132	0.123	140	0.2	4.658	A
5	193	1295	1295	0.149	193	0.2	4.177	A

2025 + Committed + Proposed, PM

Data Errors and Warnings

No errors or warnings

Junction Network

Junctions

Junction	Name	Junction type	Use circulating lanes	Arm order	Junction Delay (s)	Junction LOS
1	untitled	Standard Roundabout		1, 2, 3, 4, 5	3.42	A

Junction Network

Driving side	Lighting	Network delay (s)	Network LOS
Left	Normal/unknown	3.42	A

Traffic Demand

Demand Set Details

ID	Scenario name	Time Period name	Traffic profile type	Start time (HH:mm)	Finish time (HH:mm)	Time segment length (min)
D6	2025 + Committed + Proposed	PM	ONE HOUR	15:45	17:15	15

Vehicle mix source	PCU Factor for a HV (PCU)
HV Percentages	2.00

Demand overview (Traffic)

Arm	Linked arm	Use O-D data	Average Demand (PCU/hr)	Scaling Factor (%)
1		✓	1535	100.000
2		✓	122	100.000
3		✓	718	100.000
4		✓	111	100.000
5		✓	391	100.000

Origin-Destination Data

Demand (PCU/hr)

		To				
		1	2	3	4	5
From	1	0	119	1283	19	114
	2	18	0	41	19	44
	3	437	64	0	76	141
	4	32	15	41	0	23
	5	40	114	207	30	0

Vehicle Mix

Heavy Vehicle Percentages

		To				
		1	2	3	4	5
From	1	100	1	30	42	59
	2	6	0	0	0	2
	3	78	5	0	32	37
	4	52	7	38	0	50
	5	42	1	13	14	0

Detailed Demand Data

Demand for each time segment

Time Segment	Arm	Demand (PCU/hr)	Demand in PCU (PCU/hr)
15:45-16:00	1	1156	1156
	2	92	92
	3	541	541
	4	84	84
	5	294	294
16:00-16:15	1	1380	1380
	2	110	110
	3	645	645
	4	100	100
	5	352	352
16:15-16:30	1	1690	1690
	2	134	134
	3	791	791
	4	122	122
	5	430	430
16:30-16:45	1	1690	1690
	2	134	134
	3	791	791
	4	122	122
	5	430	430
16:45-17:00	1	1380	1380
	2	110	110
	3	645	645
	4	100	100
	5	352	352
17:00-17:15	1	1156	1156
	2	92	92
	3	541	541
	4	84	84
	5	294	294

Results

Results Summary for whole modelled period

Arm	Max RFC	Max Delay (s)	Max Queue (PCU)	Max LOS
1	0.59	3.90	1.8	A
2	0.17	5.50	0.2	A
3	0.25	2.34	0.5	A
4	0.08	3.37	0.1	A
5	0.24	2.90	0.3	A

Main Results for each time segment

15:45 - 16:00

Arm	Total Demand (PCU/hr)	Circulating flow (PCU/hr)	Capacity (PCU/hr)	RFC	Throughput (PCU/hr)	End queue (PCU)	Delay (s)	Unsignalised level of service
1	1156	354	3087	0.374	1153	0.8	2.396	A
2	92	1272	1288	0.071	92	0.1	3.056	A
3	541	183	3260	0.166	539	0.3	2.033	A
4	84	614	1836	0.046	83	0.1	2.845	A
5	294	456	1988	0.148	294	0.2	2.368	A

16:00 - 16:15

Arm	Total Demand (PCU/hr)	Circulating flow (PCU/hr)	Capacity (PCU/hr)	RFC	Throughput (PCU/hr)	End queue (PCU)	Delay (s)	Unsignalised level of service
1	1380	423	3000	0.460	1379	1.1	2.861	A
2	110	1522	1082	0.101	110	0.1	3.758	A
3	645	219	3216	0.201	645	0.4	2.153	A
4	100	735	1738	0.057	100	0.1	3.043	A
5	352	545	1915	0.184	351	0.2	2.568	A

16:15 - 16:30

Arm	Total Demand (PCU/hr)	Circulating flow (PCU/hr)	Capacity (PCU/hr)	RFC	Throughput (PCU/hr)	End queue (PCU)	Delay (s)	Unsignalised level of service
1	1690	518	2881	0.587	1687	1.8	3.880	A
2	134	1862	802	0.168	134	0.2	5.475	A
3	791	268	3156	0.251	790	0.5	2.340	A
4	122	900	1604	0.076	122	0.1	3.366	A
5	430	668	1813	0.237	430	0.3	2.903	A

16:30 - 16:45

Arm	Total Demand (PCU/hr)	Circulating flow (PCU/hr)	Capacity (PCU/hr)	RFC	Throughput (PCU/hr)	End queue (PCU)	Delay (s)	Unsignalised level of service
1	1690	519	2881	0.587	1690	1.8	3.900	A
2	134	1865	799	0.168	134	0.2	5.499	A
3	791	269	3155	0.251	791	0.5	2.340	A
4	122	901	1603	0.076	122	0.1	3.367	A
5	430	668	1813	0.237	430	0.3	2.903	A

16:45 - 17:00

Arm	Total Demand (PCU/hr)	Circulating flow (PCU/hr)	Capacity (PCU/hr)	RFC	Throughput (PCU/hr)	End queue (PCU)	Delay (s)	Unsignalised level of service
1	1380	424	2999	0.460	1383	1.1	2.877	A
2	110	1526	1079	0.102	110	0.1	3.777	A
3	645	220	3215	0.201	646	0.4	2.154	A
4	100	736	1737	0.057	100	0.1	3.046	A
5	352	546	1914	0.184	352	0.3	2.570	A

17:00 - 17:15

Arm	Total Demand (PCU/hr)	Circulating flow (PCU/hr)	Capacity (PCU/hr)	RFC	Throughput (PCU/hr)	End queue (PCU)	Delay (s)	Unsignalised level of service
1	1156	355	3085	0.375	1157	0.8	2.411	A
2	92	1277	1284	0.072	92	0.1	3.069	A
3	541	184	3259	0.166	541	0.3	2.037	A
4	84	616	1835	0.046	84	0.1	2.847	A
5	294	457	1987	0.148	295	0.2	2.374	A

Junctions 10
ARCADY 10 - Roundabout Module
Version: 10.0.4.1693 © Copyright TRL Software Limited, 2021
For sales and distribution information, program advice and maintenance, contact TRL Software: +44 (0)1344 379777 software@trl.co.uk trlsoftware.com
The users of this computer program for the solution of an engineering problem are in no way relieved of their responsibility for the correctness of the solution

Filename: J3 A160_A180.j10

Path: \\na.aecomnet.com\lfs\EMEA\Leeds-UKLDS2\Legacy\UKLDS2PFPSW001\WIP\LE_Projects\Newproje\60668866 - Humber Zero\400_Technical\Traffic & Transport\NH Comments 10.01.24\Junction Modelling\Modelling May 2024

Report generation date: 10/05/2024 08:26:30

- »2025 Base, AM
- »2025 Base, PM
- »2025 Base + Committed, AM
- »2025 Base + Committed, PM
- »2025 Base + Committed + Proposed, AM
- »2025 Base + Committed + Proposed, PM

Summary of junction performance

	AM					PM				
	Set ID	Queue (PCU)	Delay (s)	RFC	LOS	Set ID	Queue (PCU)	Delay (s)	RFC	LOS
2025 Base										
Arm 1	D1	0.4	1.72	0.26	A	D2	0.8	2.43	0.40	A
Arm 2		0.9	6.64	0.48	A		0.2	4.91	0.17	A
Arm 3		0.0	0.00	0.00	A		0.0	0.00	0.00	A
2025 Base + Committed										
Arm 1	D3	0.4	1.74	0.26	A	D4	1.2	2.95	0.49	A
Arm 2		1.1	7.35	0.52	A		0.3	6.30	0.21	A
Arm 3		0.0	0.00	0.00	A		0.0	0.00	0.00	A
2025 Base + Committed + Proposed										
Arm 1	D5	0.4	1.74	0.26	A	D6	1.6	3.43	0.56	A
Arm 2		1.2	7.44	0.54	A		0.5	8.06	0.30	A
Arm 3		0.0	0.00	0.00	A		0.0	0.00	0.00	A

There are warnings associated with one or more model runs - see the 'Data Errors and Warnings' tables for each Analysis or Demand Set.

Values shown are the highest values encountered over all time segments. Delay is the maximum value of average delay per arriving vehicle.

File summary

File Description

Title	
Location	
Site number	
Date	18/01/2024
Version	
Status	(new file)
Identifier	
Client	
Jobnumber	
Enumerator	NA\SimmonsA1
Description	

Units

Distance units	Speed units	Traffic units input	Traffic units results	Flow units	Average delay units	Total delay units	Rate of delay units
m	kph	PCU	PCU	perHour	s	-Min	perMin

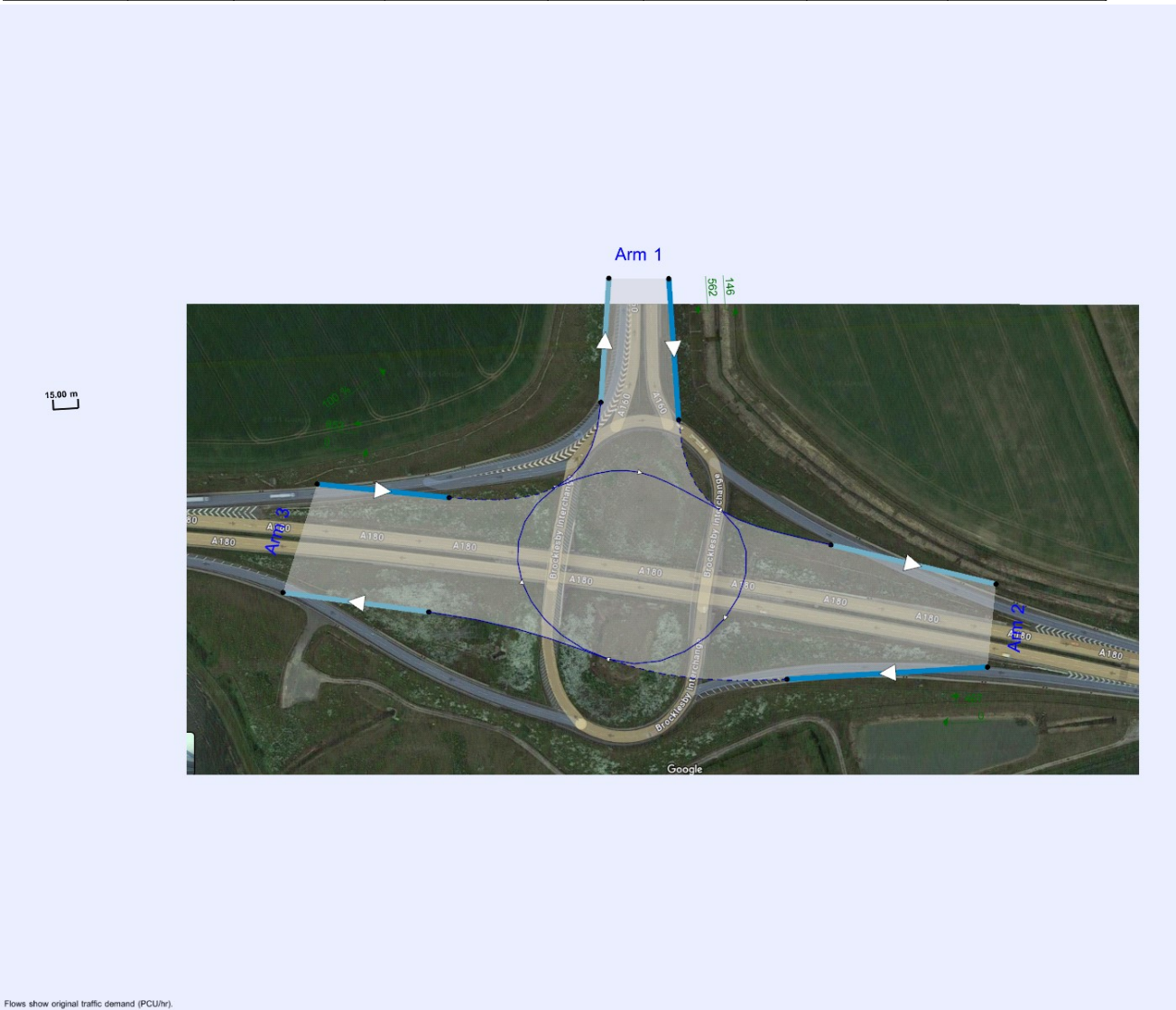

Flows show original traffic demand (PCU/hr).

The junction diagram reflects the last run of Junctions.

Analysis Options

Vehicle length (m)	Calculate Queue Percentiles	Calculate detailed queueing delay	Show lane queues in feet / metres	Show all PICADY stream intercepts	Calculate residual capacity	RFC Threshold	Average Delay threshold (s)	Queue threshold (PCU)	Use iterations with HCM roundabouts	Max number of iterations for roundabouts
5.75						0.85	36.00	20.00		500

Demand Set Summary

ID	Scenario name	Time Period name	Traffic profile type	Start time (HH:mm)	Finish time (HH:mm)	Time segment length (min)	Run automatically
D1	2025 Base	AM	ONE HOUR	06:45	08:15	15	✓
D2	2025 Base	PM	ONE HOUR	15:45	17:15	15	✓
D3	2025 Base + Committed	AM	ONE HOUR	06:45	08:15	15	✓
D4	2025 Base + Committed	PM	ONE HOUR	15:45	17:15	15	✓
D5	2025 Base + Committed + Proposed	AM	ONE HOUR	06:45	08:15	15	✓
D6	2025 Base + Committed + Proposed	PM	ONE HOUR	15:45	17:15	15	✓

Analysis Set Details

ID	Include in report	Network flow scaling factor (%)	Network capacity scaling factor (%)
A1	✓	100.000	100.000

2025 Base, AM

Data Errors and Warnings

No errors or warnings

Junction Network

Junctions

Junction	Name	Junction type	Use circulating lanes	Arm order	Junction Delay (s)	Junction LOS
1	untitled	Large Roundabout		1, 2, 3	2.13	A

Junction Network

Driving side	Lighting	Network delay (s)	Network LOS
Left	Normal/unknown	2.13	A

Arms

Arms

Arm	Name	Description	No give-way line
1	A160		
2	A180 East		
3	A180 West		

Roundabout Geometry

Arm	V - Approach road half-width (m)	E - Entry width (m)	I' - Effective flare length (m)	R - Entry radius (m)	D - Inscribed circle diameter (m)	PHI - Conflict (entry) angle (deg)	Entry only	Exit only
1	7.70	8.39	5.0	37.9	102.0	36.0		
2	3.96	5.04	5.0	25.9	102.0	44.0		
3	4.61	8.19	30.0	75.4	102.0	30.0		

Large Roundabout Data

Arm	Circulating flow (PCU/hr)	Has entry-to-exit separation	Entry-to-exit separation (m)
1	901	✓	38.00
2	1493	✓	142.00
3	492	✓	170.00

Bypass

Arm	Arm has bypass	Bypass utilisation (%)
1		
2		
3	✓	100

Slope / Intercept / Capacity

Roundabout Slope and Intercept used in model

Arm	Enter slope and intercept directly	Entered slope	Entered intercept (PCU/hr)	Final slope	Final intercept (PCU/hr)
1	✓	0.997	3042	0.997	3042
2	✓	0.587	1436	0.587	1436
3	✓	0.977	2442	0.977	2442

The slope and intercept shown above include any corrections and adjustments.

Traffic Demand

Demand Set Details

ID	Scenario name	Time Period name	Traffic profile type	Start time (HH:mm)	Finish time (HH:mm)	Time segment length (min)	Run automatically
D1	2025 Base	AM	ONE HOUR	06:45	08:15	15	✓

Vehicle mix varies over turn	Vehicle mix varies over entry	Vehicle mix source	PCU Factor for a HV (PCU)
✓	✓	HV Percentages	2.00

Demand overview (Traffic)

Arm	Linked arm	Profile type	Use O-D data	Average Demand (PCU/hr)	Scaling Factor (%)
1		ONE HOUR	✓	708	100.000
2		ONE HOUR	✓	467	100.000
3		ONE HOUR	✓	853	100.000

Origin-Destination Data

Demand (PCU/hr)

	To			
	1	2	3	
From	1	0	146	562
	2	467	0	0
	3	853	0	0

Proportions

	To			
	1	2	3	
From	1	0.00	0.21	0.79
	2	1.00	0.00	0.00
	3	1.00	0.00	0.00

Vehicle Mix

Heavy Vehicle Percentages

	To			
	1	2	3	
From	1	0	14	7
	2	3	0	0
	3	29	0	0

Average PCU Per Veh

	To			
	1	2	3	
From	1	1.000	1.140	1.070
	2	1.030	1.000	1.000
	3	1.290	1.000	1.000

Detailed Demand Data

Demand for each time segment

Time Segment	Arm	Demand (PCU/hr)	Demand in PCU (PCU/hr)
06:45-07:00	1	533	533
	2	352	352
	3	642	642
07:00-07:15	1	636	636
	2	420	420
	3	767	767
07:15-07:30	1	780	780
	2	514	514
	3	939	939
07:30-07:45	1	780	780
	2	514	514
	3	939	939
07:45-08:00	1	636	636
	2	420	420
	3	767	767
08:00-08:15	1	533	533
	2	352	352
	3	642	642

Results

Results Summary for whole modelled period

Arm	Max RFC	Max Delay (s)	Max Queue (PCU)	Max LOS	Average Demand (PCU/hr)	Total Junction Arrivals (PCU)
1	0.26	1.72	0.4	A	650	975
2	0.48	6.64	0.9	A	429	643
3	0.00	0.00	0.0	A	783	0

Main Results for each time segment

06:45 - 07:00

Arm	Total Demand (PCU/hr)	Junction demand (PCU/hr)	Junction Arrivals (PCU)	Bypass demand (PCU/hr)	Bypass exit flow (PCU/hr)	Circulating flow (PCU/hr)	Capacity (PCU/hr)	RFC	Throughput (PCU/hr)	Throughput (exit side) (PCU/hr)	Start queue (PCU)	End queue (PCU)	Delay (s)	Unsignalised level of service
1	533	533	133	0	642	0	3042	0.175	532	350	0.0	0.2	1.554	A
2	352	352	88	0	0	422	1188	0.296	350	110	0.0	0.4	4.415	A
3	642	0	0	642	0	350	2100	0.000	0	422	0.0	0.0	0.000	A

07:00 - 07:15

Arm	Total Demand (PCU/hr)	Junction demand (PCU/hr)	Junction Arrivals (PCU)	Bypass demand (PCU/hr)	Bypass exit flow (PCU/hr)	Circulating flow (PCU/hr)	Capacity (PCU/hr)	RFC	Throughput (PCU/hr)	Throughput (exit side) (PCU/hr)	Start queue (PCU)	End queue (PCU)	Delay (s)	Unsignalised level of service
1	636	636	159	0	767	0	3042	0.209	636	419	0.2	0.3	1.621	A
2	420	420	105	0	0	505	1140	0.368	419	131	0.4	0.6	5.143	A
3	767	0	0	767	0	419	2032	0.000	0	505	0.0	0.0	0.000	A

07:15 - 07:30

Arm	Total Demand (PCU/hr)	Junction demand (PCU/hr)	Junction Arrivals (PCU)	Bypass demand (PCU/hr)	Bypass exit flow (PCU/hr)	Circulating flow (PCU/hr)	Capacity (PCU/hr)	RFC	Throughput (PCU/hr)	Throughput (exit side) (PCU/hr)	Start queue (PCU)	End queue (PCU)	Delay (s)	Unsignalised level of service
1	780	780	195	0	939	0	3042	0.256	779	513	0.3	0.4	1.723	A
2	514	514	129	0	0	618	1073	0.479	513	161	0.6	0.9	6.604	A
3	939	0	0	939	0	513	1941	0.000	0	618	0.0	0.0	0.000	A

07:30 - 07:45

Arm	Total Demand (PCU/hr)	Junction demand (PCU/hr)	Junction Arrivals (PCU)	Bypass demand (PCU/hr)	Bypass exit flow (PCU/hr)	Circulating flow (PCU/hr)	Capacity (PCU/hr)	RFC	Throughput (PCU/hr)	Throughput (exit side) (PCU/hr)	Start queue (PCU)	End queue (PCU)	Delay (s)	Unsignalised level of service
1	780	780	195	0	939	0	3042	0.256	780	514	0.4	0.4	1.723	A
2	514	514	129	0	0	619	1073	0.479	514	161	0.9	0.9	6.637	A
3	939	0	0	939	0	514	1940	0.000	0	619	0.0	0.0	0.000	A

07:45 - 08:00

Arm	Total Demand (PCU/hr)	Junction demand (PCU/hr)	Junction Arrivals (PCU)	Bypass demand (PCU/hr)	Bypass exit flow (PCU/hr)	Circulating flow (PCU/hr)	Capacity (PCU/hr)	RFC	Throughput (PCU/hr)	Throughput (exit side) (PCU/hr)	Start queue (PCU)	End queue (PCU)	Delay (s)	Unsignalised level of service
1	636	636	159	0	767	0	3042	0.209	637	421	0.4	0.3	1.624	A
2	420	420	105	0	0	505	1139	0.369	421	131	0.9	0.6	5.172	A
3	767	0	0	767	0	421	2031	0.000	0	505	0.0	0.0	0.000	A

08:00 - 08:15

Arm	Total Demand (PCU/hr)	Junction demand (PCU/hr)	Junction Arrivals (PCU)	Bypass demand (PCU/hr)	Bypass exit flow (PCU/hr)	Circulating flow (PCU/hr)	Capacity (PCU/hr)	RFC	Throughput (PCU/hr)	Throughput (exit side) (PCU/hr)	Start queue (PCU)	End queue (PCU)	Delay (s)	Unsignalised level of service
1	533	533	133	0	642	0	3042	0.175	533	352	0.3	0.2	1.556	A
2	352	352	88	0	0	423	1188	0.296	352	110	0.6	0.4	4.442	A
3	642	0	0	642	0	352	2098	0.000	0	423	0.0	0.0	0.000	A

2025 Base, PM

Data Errors and Warnings

Severity	Area	Item	Description
Warning	Large Roundabout	Arm 1 - Large roundabout data	Large Roundabout Circulating Flow is zero for one or more arms.

Junction Network

Junctions

Junction	Name	Junction type	Use circulating lanes	Arm order	Junction Delay (s)	Junction LOS
1	untitled	Large Roundabout		1, 2, 3	1.93	A

Junction Network

Driving side	Lighting	Network delay (s)	Network LOS
Left	Normal/unknown	1.93	A

Arms

Arms

[same as above]

Roundabout Geometry

[same as above]

Large Roundabout Data

Arm	Circulating flow (PCU/hr)	Has entry-to-exit separation	Entry-to-exit separation (m)
1	0	✓	38.00
2	0	✓	142.00
3	0	✓	170.00

Bypass

[same as above]

Slope / Intercept / Capacity

[same as above]

Traffic Demand

Demand Set Details

ID	Scenario name	Time Period name	Traffic profile type	Start time (HH:mm)	Finish time (HH:mm)	Time segment length (min)	Run automatically
D2	2025 Base	PM	ONE HOUR	15:45	17:15	15	✓

Vehicle mix varies over turn	Vehicle mix varies over entry	Vehicle mix source	PCU Factor for a HV (PCU)
✓	✓	HV Percentages	2.00

Demand overview (Traffic)

Arm	Linked arm	Profile type	Use O-D data	Average Demand (PCU/hr)	Scaling Factor (%)
1		ONE HOUR	✓	1099	100.000
2		ONE HOUR	✓	146	100.000
3		ONE HOUR	✓	509	100.000

Origin-Destination Data

Demand (PCU/hr)

		To		
		1	2	3
From	1	0	361	738
	2	146	0	0
	3	509	0	0

Proportions

		To		
		1	2	3
From	1	0.00	0.33	0.67
	2	1.00	0.00	0.00
	3	1.00	0.00	0.00

Vehicle Mix

Heavy Vehicle Percentages

		To		
		1	2	3
From	1	0	3	37
	2	9	0	0
	3	70	0	0

Average PCU Per Veh

		To		
		1	2	3
From	1	1.000	1.030	1.370
	2	1.090	1.000	1.000
	3	1.700	1.000	1.000

Detailed Demand Data

Demand for each time segment

Time Segment	Arm	Demand (PCU/hr)	Demand in PCU (PCU/hr)
15:45-16:00	1	827	827
	2	110	110
	3	383	383
16:00-16:15	1	988	988
	2	131	131
	3	458	458
16:15-16:30	1	1210	1210
	2	161	161
	3	560	560
16:30-16:45	1	1210	1210
	2	161	161
	3	560	560
16:45-17:00	1	988	988
	2	131	131
	3	458	458
17:00-17:15	1	827	827
	2	110	110
	3	383	383

Results

Results Summary for whole modelled period

Arm	Max RFC	Max Delay (s)	Max Queue (PCU)	Max LOS	Average Demand (PCU/hr)	Total Junction Arrivals (PCU)
1	0.40	2.43	0.8	A	1008	1513
2	0.17	4.91	0.2	A	134	201
3	0.00	0.00	0.0	A	467	0

Main Results for each time segment

15:45 - 16:00

Arm	Total Demand (PCU/hr)	Junction demand (PCU/hr)	Junction Arrivals (PCU)	Bypass demand (PCU/hr)	Bypass exit flow (PCU/hr)	Circulating flow (PCU/hr)	Capacity (PCU/hr)	RFC	Throughput (PCU/hr)	Throughput (exit side) (PCU/hr)	Start queue (PCU)	End queue (PCU)	Delay (s)	Unsignalised level of service
1	827	827	207	0	383	0	3042	0.272	826	109	0.0	0.5	2.005	A
2	110	110	27	0	0	554	1111	0.099	109	271	0.0	0.1	3.918	A
3	383	0	0	383	0	109	2335	0.000	0	554	0.0	0.0	0.000	A

16:00 - 16:15

Arm	Total Demand (PCU/hr)	Junction demand (PCU/hr)	Junction Arrivals (PCU)	Bypass demand (PCU/hr)	Bypass exit flow (PCU/hr)	Circulating flow (PCU/hr)	Capacity (PCU/hr)	RFC	Throughput (PCU/hr)	Throughput (exit side) (PCU/hr)	Start queue (PCU)	End queue (PCU)	Delay (s)	Unsignalised level of service
1	988	988	247	0	458	0	3042	0.325	987	131	0.5	0.6	2.165	A
2	131	131	33	0	0	663	1047	0.125	131	324	0.1	0.2	4.285	A
3	458	0	0	458	0	131	2314	0.000	0	663	0.0	0.0	0.000	A

16:15 - 16:30

Arm	Total Demand (PCU/hr)	Junction demand (PCU/hr)	Junction Arrivals (PCU)	Bypass demand (PCU/hr)	Bypass exit flow (PCU/hr)	Circulating flow (PCU/hr)	Capacity (PCU/hr)	RFC	Throughput (PCU/hr)	Throughput (exit side) (PCU/hr)	Start queue (PCU)	End queue (PCU)	Delay (s)	Unsignalised level of service
1	1210	1210	303	0	560	0	3042	0.398	1209	160	0.6	0.8	2.426	A
2	161	161	40	0	0	812	959	0.168	160	397	0.2	0.2	4.911	A
3	560	0	0	560	0	160	2285	0.000	0	812	0.0	0.0	0.000	A

16:30 - 16:45

Arm	Total Demand (PCU/hr)	Junction demand (PCU/hr)	Junction Arrivals (PCU)	Bypass demand (PCU/hr)	Bypass exit flow (PCU/hr)	Circulating flow (PCU/hr)	Capacity (PCU/hr)	RFC	Throughput (PCU/hr)	Throughput (exit side) (PCU/hr)	Start queue (PCU)	End queue (PCU)	Delay (s)	Unsignalised level of service
1	1210	1210	303	0	560	0	3042	0.398	1210	161	0.8	0.8	2.428	A
2	161	161	40	0	0	813	959	0.168	161	397	0.2	0.2	4.915	A
3	560	0	0	560	0	161	2285	0.000	0	813	0.0	0.0	0.000	A

16:45 - 17:00

Arm	Total Demand (PCU/hr)	Junction demand (PCU/hr)	Junction Arrivals (PCU)	Bypass demand (PCU/hr)	Bypass exit flow (PCU/hr)	Circulating flow (PCU/hr)	Capacity (PCU/hr)	RFC	Throughput (PCU/hr)	Throughput (exit side) (PCU/hr)	Start queue (PCU)	End queue (PCU)	Delay (s)	Unsignalised level of service
1	988	988	247	0	458	0	3042	0.325	989	131	0.8	0.6	2.167	A
2	131	131	33	0	0	664	1046	0.125	131	325	0.2	0.2	4.290	A
3	458	0	0	458	0	131	2314	0.000	0	664	0.0	0.0	0.000	A

17:00 - 17:15

Arm	Total Demand (PCU/hr)	Junction demand (PCU/hr)	Junction Arrivals (PCU)	Bypass demand (PCU/hr)	Bypass exit flow (PCU/hr)	Circulating flow (PCU/hr)	Capacity (PCU/hr)	RFC	Throughput (PCU/hr)	Throughput (exit side) (PCU/hr)	Start queue (PCU)	End queue (PCU)	Delay (s)	Unsignalised level of service
1	827	827	207	0	383	0	3042	0.272	828	110	0.6	0.5	2.011	A
2	110	110	27	0	0	556	1110	0.099	110	272	0.2	0.1	3.927	A
3	383	0	0	383	0	110	2334	0.000	0	556	0.0	0.0	0.000	A

2025 Base + Committed, AM

Data Errors and Warnings

Severity	Area	Item	Description
Warning	Large Roundabout	Arm 1 - Large roundabout data	Large Roundabout Circulating Flow is zero for one or more arms.

Junction Network

Junctions

Junction	Name	Junction type	Use circulating lanes	Arm order	Junction Delay (s)	Junction LOS
1	untitled	Large Roundabout		1, 2, 3	2.13	A

Junction Network

Driving side	Lighting	Network delay (s)	Network LOS
Left	Normal/unknown	2.13	A

Arms

Arms

[same as above]

Roundabout Geometry

[same as above]

Large Roundabout Data

Arm	Circulating flow (PCU/hr)	Has entry-to-exit separation	Entry-to-exit separation (m)
1	0	✓	38.00
2	0	✓	142.00
3	0	✓	170.00

Bypass

[same as above]

Slope / Intercept / Capacity

[same as above]

Traffic Demand

Demand Set Details

ID	Scenario name	Time Period name	Traffic profile type	Start time (HH:mm)	Finish time (HH:mm)	Time segment length (min)	Run automatically
D3	2025 Base + Committed	AM	ONE HOUR	06:45	08:15	15	✓

Vehicle mix varies over turn	Vehicle mix varies over entry	Vehicle mix source	PCU Factor for a HV (PCU)
✓	✓	HV Percentages	2.00

Demand overview (Traffic)

Arm	Linked arm	Profile type	Use O-D data	Average Demand (PCU/hr)	Scaling Factor (%)
1		ONE HOUR	✓	725	100.000
2		ONE HOUR	✓	506	100.000
3		ONE HOUR	✓	1107	100.000

Origin-Destination Data

Demand (PCU/hr)

		To		
		1	2	3
From	1	0	146	579
	2	506	0	0
	3	1107	0	0

Proportions

		To		
		1	2	3
From	1	0.00	0.20	0.80
	2	1.00	0.00	0.00
	3	1.00	0.00	0.00

Vehicle Mix

Heavy Vehicle Percentages

		To		
		1	2	3
From	1	0	14	7
	2	3	0	0
	3	29	0	0

Average PCU Per Veh

		To		
		1	2	3
From	1	1.000	1.140	1.070
	2	1.030	1.000	1.000
	3	1.290	1.000	1.000

Detailed Demand Data

Demand for each time segment

Time Segment	Arm	Demand (PCU/hr)	Demand in PCU (PCU/hr)
06:45-07:00	1	546	546
	2	381	381
	3	833	833
07:00-07:15	1	652	652
	2	455	455
	3	995	995
07:15-07:30	1	798	798
	2	557	557
	3	1219	1219
07:30-07:45	1	798	798
	2	557	557
	3	1219	1219
07:45-08:00	1	652	652
	2	455	455
	3	995	995
08:00-08:15	1	546	546
	2	381	381
	3	833	833

Results

Results Summary for whole modelled period

Arm	Max RFC	Max Delay (s)	Max Queue (PCU)	Max LOS	Average Demand (PCU/hr)	Total Junction Arrivals (PCU)
1	0.26	1.74	0.4	A	665	998
2	0.52	7.35	1.1	A	464	696
3	0.00	0.00	0.0	A	1016	0

Main Results for each time segment

06:45 - 07:00

Arm	Total Demand (PCU/hr)	Junction demand (PCU/hr)	Junction Arrivals (PCU)	Bypass demand (PCU/hr)	Bypass exit flow (PCU/hr)	Circulating flow (PCU/hr)	Capacity (PCU/hr)	RFC	Throughput (PCU/hr)	Throughput (exit side) (PCU/hr)	Start queue (PCU)	End queue (PCU)	Delay (s)	Unsignalised level of service
1	546	546	136	0	833	0	3042	0.179	545	379	0.0	0.2	1.561	A
2	381	381	95	0	0	435	1181	0.323	379	110	0.0	0.5	4.615	A
3	833	0	0	833	0	379	2072	0.000	0	435	0.0	0.0	0.000	A

07:00 - 07:15

Arm	Total Demand (PCU/hr)	Junction demand (PCU/hr)	Junction Arrivals (PCU)	Bypass demand (PCU/hr)	Bypass exit flow (PCU/hr)	Circulating flow (PCU/hr)	Capacity (PCU/hr)	RFC	Throughput (PCU/hr)	Throughput (exit side) (PCU/hr)	Start queue (PCU)	End queue (PCU)	Delay (s)	Unsignalised level of service
1	652	652	163	0	995	0	3042	0.214	652	454	0.2	0.3	1.630	A
2	455	455	114	0	0	520	1131	0.402	454	131	0.5	0.7	5.474	A
3	995	0	0	995	0	454	1998	0.000	0	520	0.0	0.0	0.000	A

07:15 - 07:30

Arm	Total Demand (PCU/hr)	Junction demand (PCU/hr)	Junction Arrivals (PCU)	Bypass demand (PCU/hr)	Bypass exit flow (PCU/hr)	Circulating flow (PCU/hr)	Capacity (PCU/hr)	RFC	Throughput (PCU/hr)	Throughput (exit side) (PCU/hr)	Start queue (PCU)	End queue (PCU)	Delay (s)	Unsignalised level of service
1	798	798	200	0	1219	0	3042	0.262	798	555	0.3	0.4	1.737	A
2	557	557	139	0	0	637	1062	0.525	555	161	0.7	1.1	7.295	A
3	1219	0	0	1219	0	555	1899	0.000	0	637	0.0	0.0	0.000	A

07:30 - 07:45

Arm	Total Demand (PCU/hr)	Junction demand (PCU/hr)	Junction Arrivals (PCU)	Bypass demand (PCU/hr)	Bypass exit flow (PCU/hr)	Circulating flow (PCU/hr)	Capacity (PCU/hr)	RFC	Throughput (PCU/hr)	Throughput (exit side) (PCU/hr)	Start queue (PCU)	End queue (PCU)	Delay (s)	Unsignalised level of service
1	798	798	200	0	1219	0	3042	0.262	798	557	0.4	0.4	1.737	A
2	557	557	139	0	0	637	1062	0.525	557	161	1.1	1.1	7.346	A
3	1219	0	0	1219	0	557	1898	0.000	0	637	0.0	0.0	0.000	A

07:45 - 08:00

Arm	Total Demand (PCU/hr)	Junction demand (PCU/hr)	Junction Arrivals (PCU)	Bypass demand (PCU/hr)	Bypass exit flow (PCU/hr)	Circulating flow (PCU/hr)	Capacity (PCU/hr)	RFC	Throughput (PCU/hr)	Throughput (exit side) (PCU/hr)	Start queue (PCU)	End queue (PCU)	Delay (s)	Unsignalised level of service
1	652	652	163	0	995	0	3042	0.214	652	457	0.4	0.3	1.633	A
2	455	455	114	0	0	521	1130	0.402	457	131	1.1	0.7	5.517	A
3	995	0	0	995	0	457	1996	0.000	0	521	0.0	0.0	0.000	A

08:00 - 08:15

Arm	Total Demand (PCU/hr)	Junction demand (PCU/hr)	Junction Arrivals (PCU)	Bypass demand (PCU/hr)	Bypass exit flow (PCU/hr)	Circulating flow (PCU/hr)	Capacity (PCU/hr)	RFC	Throughput (PCU/hr)	Throughput (exit side) (PCU/hr)	Start queue (PCU)	End queue (PCU)	Delay (s)	Unsignalised level of service
1	546	546	136	0	833	0	3042	0.179	546	382	0.3	0.2	1.564	A
2	381	381	95	0	0	436	1180	0.323	382	110	0.7	0.5	4.651	A
3	833	0	0	833	0	382	2069	0.000	0	436	0.0	0.0	0.000	A

2025 Base + Committed, PM

Data Errors and Warnings

Severity	Area	Item	Description
Warning	Large Roundabout	Arm 1 - Large roundabout data	Large Roundabout Circulating Flow is zero for one or more arms.

Junction Network

Junctions

Junction	Name	Junction type	Use circulating lanes	Arm order	Junction Delay (s)	Junction LOS
1	untitled	Large Roundabout		1, 2, 3	2.40	A

Junction Network

Driving side	Lighting	Network delay (s)	Network LOS
Left	Normal/unknown	2.40	A

Arms

Arms

[same as above]

Roundabout Geometry

[same as above]

Large Roundabout Data

Arm	Circulating flow (PCU/hr)	Has entry-to-exit separation	Entry-to-exit separation (m)
1	0	✓	38.00
2	0	✓	142.00
3	0	✓	170.00

Bypass

[same as above]

Slope / Intercept / Capacity

[same as above]

Traffic Demand

Demand Set Details

ID	Scenario name	Time Period name	Traffic profile type	Start time (HH:mm)	Finish time (HH:mm)	Time segment length (min)	Run automatically
D4	2025 Base + Committed	PM	ONE HOUR	15:45	17:15	15	✓

Vehicle mix varies over turn	Vehicle mix varies over entry	Vehicle mix source	PCU Factor for a HV (PCU)
✓	✓	HV Percentages	2.00

Demand overview (Traffic)

Arm	Linked arm	Profile type	Use O-D data	Average Demand (PCU/hr)	Scaling Factor (%)
1		ONE HOUR	✓	1367	100.000
2		ONE HOUR	✓	148	100.000
3		ONE HOUR	✓	553	100.000

Origin-Destination Data

Demand (PCU/hr)

	To			
	1	2	3	
From	1	0	361	1006
	2	148	0	0
	3	553	0	0

Proportions

	To			
	1	2	3	
From	1	0.00	0.26	0.74
	2	1.00	0.00	0.00
	3	1.00	0.00	0.00

Vehicle Mix

Heavy Vehicle Percentages

	To			
	1	2	3	
From	1	0	3	37
	2	9	0	0
	3	70	0	0

Average PCU Per Veh

	To			
	1	2	3	
From	1	1.000	1.030	1.370
	2	1.090	1.000	1.000
	3	1.700	1.000	1.000

Detailed Demand Data

Demand for each time segment

Time Segment	Arm	Demand (PCU/hr)	Demand in PCU (PCU/hr)
15:45-16:00	1	1029	1029
	2	111	111
	3	416	416
16:00-16:15	1	1229	1229
	2	133	133
	3	497	497
16:15-16:30	1	1505	1505
	2	163	163
	3	609	609
16:30-16:45	1	1505	1505
	2	163	163
	3	609	609
16:45-17:00	1	1229	1229
	2	133	133
	3	497	497
17:00-17:15	1	1029	1029
	2	111	111
	3	416	416

Results

Results Summary for whole modelled period

Arm	Max RFC	Max Delay (s)	Max Queue (PCU)	Max LOS	Average Demand (PCU/hr)	Total Junction Arrivals (PCU)
1	0.49	2.95	1.2	A	1254	1882
2	0.21	6.30	0.3	A	136	204
3	0.00	0.00	0.0	A	507	0

Main Results for each time segment

15:45 - 16:00

Arm	Total Demand (PCU/hr)	Junction demand (PCU/hr)	Junction Arrivals (PCU)	Bypass demand (PCU/hr)	Bypass exit flow (PCU/hr)	Circulating flow (PCU/hr)	Capacity (PCU/hr)	RFC	Throughput (PCU/hr)	Throughput (exit side) (PCU/hr)	Start queue (PCU)	End queue (PCU)	Delay (s)	Unsignalised level of service
1	1029	1029	257	0	416	0	3042	0.338	1027	111	0.0	0.6	2.248	A
2	111	111	28	0	0	755	993	0.112	111	271	0.0	0.1	4.447	A
3	416	0	0	416	0	111	2334	0.000	0	755	0.0	0.0	0.000	A

16:00 - 16:15

Arm	Total Demand (PCU/hr)	Junction demand (PCU/hr)	Junction Arrivals (PCU)	Bypass demand (PCU/hr)	Bypass exit flow (PCU/hr)	Circulating flow (PCU/hr)	Capacity (PCU/hr)	RFC	Throughput (PCU/hr)	Throughput (exit side) (PCU/hr)	Start queue (PCU)	End queue (PCU)	Delay (s)	Unsignalised level of service
1	1229	1229	307	0	497	0	3042	0.404	1228	133	0.6	0.9	2.499	A
2	133	133	33	0	0	904	905	0.147	133	324	0.1	0.2	5.077	A
3	497	0	0	497	0	133	2312	0.000	0	904	0.0	0.0	0.000	A

16:15 - 16:30

Arm	Total Demand (PCU/hr)	Junction demand (PCU/hr)	Junction Arrivals (PCU)	Bypass demand (PCU/hr)	Bypass exit flow (PCU/hr)	Circulating flow (PCU/hr)	Capacity (PCU/hr)	RFC	Throughput (PCU/hr)	Throughput (exit side) (PCU/hr)	Start queue (PCU)	End queue (PCU)	Delay (s)	Unsignalised level of service
1	1505	1505	376	0	609	0	3042	0.495	1504	163	0.9	1.2	2.946	A
2	163	163	41	0	0	1107	786	0.207	163	397	0.2	0.3	6.285	A
3	609	0	0	609	0	163	2283	0.000	0	1107	0.0	0.0	0.000	A

16:30 - 16:45

Arm	Total Demand (PCU/hr)	Junction demand (PCU/hr)	Junction Arrivals (PCU)	Bypass demand (PCU/hr)	Bypass exit flow (PCU/hr)	Circulating flow (PCU/hr)	Capacity (PCU/hr)	RFC	Throughput (PCU/hr)	Throughput (exit side) (PCU/hr)	Start queue (PCU)	End queue (PCU)	Delay (s)	Unsignalised level of service
1	1505	1505	376	0	609	0	3042	0.495	1505	163	1.2	1.2	2.951	A
2	163	163	41	0	0	1108	786	0.207	163	397	0.3	0.3	6.299	A
3	609	0	0	609	0	163	2283	0.000	0	1108	0.0	0.0	0.000	A

16:45 - 17:00

Arm	Total Demand (PCU/hr)	Junction demand (PCU/hr)	Junction Arrivals (PCU)	Bypass demand (PCU/hr)	Bypass exit flow (PCU/hr)	Circulating flow (PCU/hr)	Capacity (PCU/hr)	RFC	Throughput (PCU/hr)	Throughput (exit side) (PCU/hr)	Start queue (PCU)	End queue (PCU)	Delay (s)	Unsignalised level of service
1	1229	1229	307	0	497	0	3042	0.404	1230	133	1.2	0.9	2.505	A
2	133	133	33	0	0	905	904	0.147	133	325	0.3	0.2	5.091	A
3	497	0	0	497	0	133	2312	0.000	0	905	0.0	0.0	0.000	A

17:00 - 17:15

Arm	Total Demand (PCU/hr)	Junction demand (PCU/hr)	Junction Arrivals (PCU)	Bypass demand (PCU/hr)	Bypass exit flow (PCU/hr)	Circulating flow (PCU/hr)	Capacity (PCU/hr)	RFC	Throughput (PCU/hr)	Throughput (exit side) (PCU/hr)	Start queue (PCU)	End queue (PCU)	Delay (s)	Unsignalised level of service
1	1029	1029	257	0	416	0	3042	0.338	1030	112	0.9	0.6	2.257	A
2	111	111	28	0	0	758	991	0.112	112	272	0.2	0.1	4.462	A
3	416	0	0	416	0	112	2333	0.000	0	758	0.0	0.0	0.000	A

2025 Base + Committed + Proposed, AM

Data Errors and Warnings

Severity	Area	Item	Description
Warning	Large Roundabout	Arm 1 - Large roundabout data	Large Roundabout Circulating Flow is zero for one or more arms.

Junction Network

Junctions

Junction	Name	Junction type	Use circulating lanes	Arm order	Junction Delay (s)	Junction LOS
1	untitled	Large Roundabout		1, 2, 3	2.04	A

Junction Network

Driving side	Lighting	Network delay (s)	Network LOS
Left	Normal/unknown	2.04	A

Arms

Arms

[same as above]

Roundabout Geometry

[same as above]

Large Roundabout Data

Arm	Circulating flow (PCU/hr)	Has entry-to-exit separation	Entry-to-exit separation (m)
1	0	✓	38.00
2	0	✓	142.00
3	0	✓	170.00

Bypass

[same as above]

Slope / Intercept / Capacity

[same as above]

Traffic Demand

Demand Set Details

ID	Scenario name	Time Period name	Traffic profile type	Start time (HH:mm)	Finish time (HH:mm)	Time segment length (min)	Run automatically
D5	2025 Base + Committed + Proposed	AM	ONE HOUR	06:45	08:15	15	✓

Vehicle mix varies over turn	Vehicle mix varies over entry	Vehicle mix source	PCU Factor for a HV (PCU)
✓	✓	HV Percentages	2.00

Demand overview (Traffic)

Arm	Linked arm	Profile type	Use O-D data	Average Demand (PCU/hr)	Scaling Factor (%)
1		ONE HOUR	✓	725	100.000
2		ONE HOUR	✓	522	100.000
3		ONE HOUR	✓	1276	100.000

Origin-Destination Data

Demand (PCU/hr)

	To			
	1	2	3	
From	1	0	163	562
	2	522	0	0
	3	1276	0	0

Proportions

	To			
	1	2	3	
From	1	0.00	0.22	0.78
	2	1.00	0.00	0.00
	3	1.00	0.00	0.00

Vehicle Mix

Heavy Vehicle Percentages

	To			
	1	2	3	
From	1	0	14	7
	2	3	0	0
	3	29	0	0

Average PCU Per Veh

	To			
	1	2	3	
From	1	1.000	1.140	1.070
	2	1.030	1.000	1.000
	3	1.290	1.000	1.000

Detailed Demand Data

Demand for each time segment

Time Segment	Arm	Demand (PCU/hr)	Demand in PCU (PCU/hr)
06:45-07:00	1	546	546
	2	393	393
	3	961	961
07:00-07:15	1	652	652
	2	469	469
	3	1147	1147
07:15-07:30	1	798	798
	2	575	575
	3	1405	1405
07:30-07:45	1	798	798
	2	575	575
	3	1405	1405
07:45-08:00	1	652	652
	2	469	469
	3	1147	1147
08:00-08:15	1	546	546
	2	393	393
	3	961	961

Results

Results Summary for whole modelled period

Arm	Max RFC	Max Delay (s)	Max Queue (PCU)	Max LOS	Average Demand (PCU/hr)	Total Junction Arrivals (PCU)
1	0.26	1.74	0.4	A	665	998
2	0.54	7.44	1.2	A	479	718
3	0.00	0.00	0.0	A	1171	0

Main Results for each time segment

06:45 - 07:00

Arm	Total Demand (PCU/hr)	Junction demand (PCU/hr)	Junction Arrivals (PCU)	Bypass demand (PCU/hr)	Bypass exit flow (PCU/hr)	Circulating flow (PCU/hr)	Capacity (PCU/hr)	RFC	Throughput (PCU/hr)	Throughput (exit side) (PCU/hr)	Start queue (PCU)	End queue (PCU)	Delay (s)	Unsignalised level of service
1	546	546	136	0	961	0	3042	0.179	545	391	0.0	0.2	1.564	A
2	393	393	98	0	0	422	1188	0.331	391	123	0.0	0.5	4.641	A
3	961	0	0	961	0	391	2060	0.000	0	422	0.0	0.0	0.000	A

07:00 - 07:15

Arm	Total Demand (PCU/hr)	Junction demand (PCU/hr)	Junction Arrivals (PCU)	Bypass demand (PCU/hr)	Bypass exit flow (PCU/hr)	Circulating flow (PCU/hr)	Capacity (PCU/hr)	RFC	Throughput (PCU/hr)	Throughput (exit side) (PCU/hr)	Start queue (PCU)	End queue (PCU)	Delay (s)	Unsignalised level of service
1	652	652	163	0	1147	0	3042	0.214	652	468	0.2	0.3	1.633	A
2	469	469	117	0	0	505	1140	0.412	468	146	0.5	0.7	5.518	A
3	1147	0	0	1147	0	468	1984	0.000	0	505	0.0	0.0	0.000	A

07:15 - 07:30

Arm	Total Demand (PCU/hr)	Junction demand (PCU/hr)	Junction Arrivals (PCU)	Bypass demand (PCU/hr)	Bypass exit flow (PCU/hr)	Circulating flow (PCU/hr)	Capacity (PCU/hr)	RFC	Throughput (PCU/hr)	Throughput (exit side) (PCU/hr)	Start queue (PCU)	End queue (PCU)	Delay (s)	Unsignalised level of service
1	798	798	200	0	1405	0	3042	0.262	798	573	0.3	0.4	1.739	A
2	575	575	144	0	0	618	1073	0.536	573	179	0.7	1.2	7.389	A
3	1405	0	0	1405	0	573	1882	0.000	0	618	0.0	0.0	0.000	A

07:30 - 07:45

Arm	Total Demand (PCU/hr)	Junction demand (PCU/hr)	Junction Arrivals (PCU)	Bypass demand (PCU/hr)	Bypass exit flow (PCU/hr)	Circulating flow (PCU/hr)	Capacity (PCU/hr)	RFC	Throughput (PCU/hr)	Throughput (exit side) (PCU/hr)	Start queue (PCU)	End queue (PCU)	Delay (s)	Unsignalised level of service
1	798	798	200	0	1405	0	3042	0.262	798	575	0.4	0.4	1.739	A
2	575	575	144	0	0	619	1073	0.536	575	179	1.2	1.2	7.444	A
3	1405	0	0	1405	0	575	1881	0.000	0	619	0.0	0.0	0.000	A

07:45 - 08:00

Arm	Total Demand (PCU/hr)	Junction demand (PCU/hr)	Junction Arrivals (PCU)	Bypass demand (PCU/hr)	Bypass exit flow (PCU/hr)	Circulating flow (PCU/hr)	Capacity (PCU/hr)	RFC	Throughput (PCU/hr)	Throughput (exit side) (PCU/hr)	Start queue (PCU)	End queue (PCU)	Delay (s)	Unsignalised level of service
1	652	652	163	0	1147	0	3042	0.214	652	471	0.4	0.3	1.633	A
2	469	469	117	0	0	506	1139	0.412	471	147	1.2	0.7	5.563	A
3	1147	0	0	1147	0	471	1982	0.000	0	506	0.0	0.0	0.000	A

08:00 - 08:15

Arm	Total Demand (PCU/hr)	Junction demand (PCU/hr)	Junction Arrivals (PCU)	Bypass demand (PCU/hr)	Bypass exit flow (PCU/hr)	Circulating flow (PCU/hr)	Capacity (PCU/hr)	RFC	Throughput (PCU/hr)	Throughput (exit side) (PCU/hr)	Start queue (PCU)	End queue (PCU)	Delay (s)	Unsignalised level of service
1	546	546	136	0	961	0	3042	0.179	546	394	0.3	0.2	1.566	A
2	393	393	98	0	0	423	1188	0.331	394	123	0.7	0.5	4.678	A
3	961	0	0	961	0	394	2057	0.000	0	423	0.0	0.0	0.000	A

2025 Base + Committed + Proposed, PM

Data Errors and Warnings

Severity	Area	Item	Description
Warning	Large Roundabout	Arm 1 - Large roundabout data	Large Roundabout Circulating Flow is zero for one or more arms.

Junction Network

Junctions

Junction	Name	Junction type	Use circulating lanes	Arm order	Junction Delay (s)	Junction LOS
1	untitled	Large Roundabout		1, 2, 3	2.98	A

Junction Network

Driving side	Lighting	Network delay (s)	Network LOS
Left	Normal/unknown	2.98	A

Arms

Arms

[same as above]

Roundabout Geometry

[same as above]

Large Roundabout Data

Arm	Circulating flow (PCU/hr)	Has entry-to-exit separation	Entry-to-exit separation (m)
1	0	✓	38.00
2	0	✓	142.00
3	0	✓	170.00

Bypass

[same as above]

Slope / Intercept / Capacity

[same as above]

Traffic Demand

Demand Set Details

ID	Scenario name	Time Period name	Traffic profile type	Start time (HH:mm)	Finish time (HH:mm)	Time segment length (min)	Run automatically
D6	2025 Base + Committed + Proposed	PM	ONE HOUR	15:45	17:15	15	✓

Vehicle mix varies over turn	Vehicle mix varies over entry	Vehicle mix source	PCU Factor for a HV (PCU)
✓	✓	HV Percentages	2.00

Demand overview (Traffic)

Arm	Linked arm	Profile type	Use O-D data	Average Demand (PCU/hr)	Scaling Factor (%)
1		ONE HOUR	✓	1561	100.000
2		ONE HOUR	✓	186	100.000
3		ONE HOUR	✓	553	100.000

Origin-Destination Data

Demand (PCU/hr)

		To		
		1	2	3
From	1	0	409	1152
	2	186	0	0
	3	553	0	0

Proportions

		To		
		1	2	3
From	1	0.00	0.26	0.74
	2	1.00	0.00	0.00
	3	1.00	0.00	0.00

Vehicle Mix

Heavy Vehicle Percentages

		To		
		1	2	3
From	1	0	3	37
	2	9	0	0
	3	70	0	0

Average PCU Per Veh

		To		
		1	2	3
From	1	1.000	1.030	1.370
	2	1.090	1.000	1.000
	3	1.700	1.000	1.000

Detailed Demand Data

Demand for each time segment

Time Segment	Arm	Demand (PCU/hr)	Demand in PCU (PCU/hr)
15:45-16:00	1	1175	1175
	2	140	140
	3	416	416
16:00-16:15	1	1403	1403
	2	167	167
	3	497	497
16:15-16:30	1	1719	1719
	2	205	205
	3	609	609
16:30-16:45	1	1719	1719
	2	205	205
	3	609	609
16:45-17:00	1	1403	1403
	2	167	167
	3	497	497
17:00-17:15	1	1175	1175
	2	140	140
	3	416	416

Results

Results Summary for whole modelled period

Arm	Max RFC	Max Delay (s)	Max Queue (PCU)	Max LOS	Average Demand (PCU/hr)	Total Junction Arrivals (PCU)
1	0.56	3.43	1.6	A	1432	2149
2	0.30	8.06	0.5	A	171	256
3	0.00	0.00	0.0	A	507	0

Main Results for each time segment

15:45 - 16:00

Arm	Total Demand (PCU/hr)	Junction demand (PCU/hr)	Junction Arrivals (PCU)	Bypass demand (PCU/hr)	Bypass exit flow (PCU/hr)	Circulating flow (PCU/hr)	Capacity (PCU/hr)	RFC	Throughput (PCU/hr)	Throughput (exit side) (PCU/hr)	Start queue (PCU)	End queue (PCU)	Delay (s)	Unsignalised level of service
1	1175	1175	294	0	416	0	3042	0.386	1172	139	0.0	0.8	2.423	A
2	140	140	35	0	0	865	928	0.151	139	307	0.0	0.2	4.969	A
3	416	0	0	416	0	139	2306	0.000	0	865	0.0	0.0	0.000	A

16:00 - 16:15

Arm	Total Demand (PCU/hr)	Junction demand (PCU/hr)	Junction Arrivals (PCU)	Bypass demand (PCU/hr)	Bypass exit flow (PCU/hr)	Circulating flow (PCU/hr)	Capacity (PCU/hr)	RFC	Throughput (PCU/hr)	Throughput (exit side) (PCU/hr)	Start queue (PCU)	End queue (PCU)	Delay (s)	Unsignalised level of service
1	1403	1403	351	0	497	0	3042	0.461	1402	167	0.8	1.1	2.767	A
2	167	167	42	0	0	1035	829	0.202	167	367	0.2	0.3	5.927	A
3	497	0	0	497	0	167	2279	0.000	0	1035	0.0	0.0	0.000	A

16:15 - 16:30

Arm	Total Demand (PCU/hr)	Junction demand (PCU/hr)	Junction Arrivals (PCU)	Bypass demand (PCU/hr)	Bypass exit flow (PCU/hr)	Circulating flow (PCU/hr)	Capacity (PCU/hr)	RFC	Throughput (PCU/hr)	Throughput (exit side) (PCU/hr)	Start queue (PCU)	End queue (PCU)	Delay (s)	Unsignalised level of service
1	1719	1719	430	0	609	0	3042	0.565	1716	204	1.1	1.6	3.418	A
2	205	205	51	0	0	1267	692	0.296	204	450	0.3	0.5	8.023	A
3	609	0	0	609	0	204	2243	0.000	0	1267	0.0	0.0	0.000	A

16:30 - 16:45

Arm	Total Demand (PCU/hr)	Junction demand (PCU/hr)	Junction Arrivals (PCU)	Bypass demand (PCU/hr)	Bypass exit flow (PCU/hr)	Circulating flow (PCU/hr)	Capacity (PCU/hr)	RFC	Throughput (PCU/hr)	Throughput (exit side) (PCU/hr)	Start queue (PCU)	End queue (PCU)	Delay (s)	Unsignalised level of service
1	1719	1719	430	0	609	0	3042	0.565	1719	205	1.6	1.6	3.429	A
2	205	205	51	0	0	1268	691	0.296	205	450	0.5	0.5	8.062	A
3	609	0	0	609	0	205	2242	0.000	0	1268	0.0	0.0	0.000	A

16:45 - 17:00

Arm	Total Demand (PCU/hr)	Junction demand (PCU/hr)	Junction Arrivals (PCU)	Bypass demand (PCU/hr)	Bypass exit flow (PCU/hr)	Circulating flow (PCU/hr)	Capacity (PCU/hr)	RFC	Throughput (PCU/hr)	Throughput (exit side) (PCU/hr)	Start queue (PCU)	End queue (PCU)	Delay (s)	Unsignalised level of service
1	1403	1403	351	0	497	0	3042	0.461	1405	168	1.6	1.1	2.779	A
2	167	167	42	0	0	1037	827	0.202	168	368	0.5	0.3	5.958	A
3	497	0	0	497	0	168	2278	0.000	0	1037	0.0	0.0	0.000	A

17:00 - 17:15

Arm	Total Demand (PCU/hr)	Junction demand (PCU/hr)	Junction Arrivals (PCU)	Bypass demand (PCU/hr)	Bypass exit flow (PCU/hr)	Circulating flow (PCU/hr)	Capacity (PCU/hr)	RFC	Throughput (PCU/hr)	Throughput (exit side) (PCU/hr)	Start queue (PCU)	End queue (PCU)	Delay (s)	Unsignalised level of service
1	1175	1175	294	0	416	0	3042	0.386	1176	140	1.1	0.8	2.434	A
2	140	140	35	0	0	868	926	0.151	140	308	0.3	0.2	4.993	A
3	416	0	0	416	0	140	2305	0.000	0	868	0.0	0.0	0.000	A

Junctions 10
ARCADY 10 - Roundabout Module
Version: 10.0.4.1693 © Copyright TRL Software Limited, 2021
For sales and distribution information, program advice and maintenance, contact TRL Software: +44 (0)1344 379777 software@trl.co.uk trlsoftware.com
The users of this computer program for the solution of an engineering problem are in no way relieved of their responsibility for the correctness of the solution

Filename: J4 M180_A15_A18 Calibrate.j10

Path: \\na.aecomnet.com\lfs\EMEA\Leeds-UKLDS2\Legacy\UKLDS2PFPSW001\WIP\LE_Projects\Newproje\60668866 - Humber Zero\400_Technical\Traffic & Transport\NH Comments 10.01.24\Junction Modelling\Modelling May 2024

Report generation date: 08/05/2024 13:08:13

- »2025 Base, AM
- »2025 Base, PM
- »2025 Base + Committed, AM
- »2025 Base + Committed, PM
- »2025 Base + Committed + Proposed, AM
- »2025 Base + Committed + Proposed, PM

Summary of junction performance

	AM					PM				
	Set ID	Queue (PCU)	Delay (s)	RFC	LOS	Set ID	Queue (PCU)	Delay (s)	RFC	LOS
2025 Base										
Arm 1	D1	1.3	7.82	0.54	A	D2	27.2	113.85	1.04	F
Arm 2		6.9	28.19	0.88	D		2.6	13.57	0.72	B
Arm 3		11.5	46.71	0.94	E		14.4	52.27	0.96	F
Arm 4		4.1	72.78	0.84	F		1.6	38.46	0.61	E
Arm 5		7.3	17.32	0.88	C		4.8	11.48	0.82	B
2025 Base + Committed										
Arm 1	D3	1.5	9.07	0.57	A	D4	49.2	184.47	1.12	F
Arm 2		20.0	74.55	1.00	F		2.7	13.96	0.73	B
Arm 3		38.6	134.11	1.07	F		16.0	57.90	0.97	F
Arm 4		15.3	215.30	1.10	F		1.5	36.68	0.59	E
Arm 5		14.3	31.95	0.94	D		5.0	12.00	0.83	B
2025 Base + Committed + Proposed										
Arm 1	D5	1.4	8.76	0.57	A	D6	4.1	16.30	0.80	C
Arm 2		17.6	66.77	0.98	F		8.2	43.52	0.91	E
Arm 3		39.3	136.09	1.07	F		3.3	18.30	0.76	C
Arm 4		15.4	216.11	1.10	F		0.6	14.04	0.35	B
Arm 5		28.7	57.72	1.00	F		2.3	5.29	0.68	A

There are warnings associated with one or more model runs - see the 'Data Errors and Warnings' tables for each Analysis or Demand Set.

Values shown are the highest values encountered over all time segments. Delay is the maximum value of average delay per arriving vehicle.

File summary

File Description

Title	
Location	
Site number	
Date	18/01/2024
Version	
Status	(new file)
Identifier	
Client	
Jobnumber	
Enumerator	NA\SimmonsA1
Description	

Units

Distance units	Speed units	Traffic units input	Traffic units results	Flow units	Average delay units	Total delay units	Rate of delay units
m	kph	PCU	PCU	perHour	s	-Min	perMin

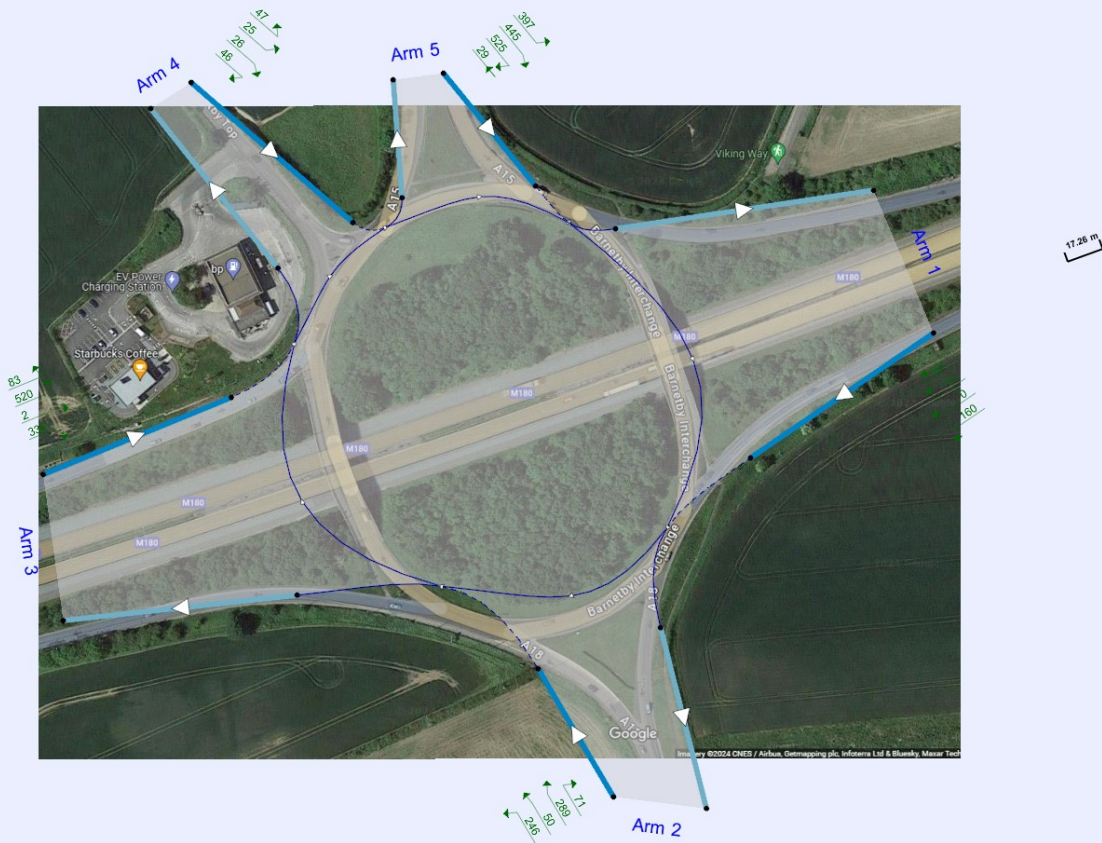

Flows show original traffic demand (PCU/hr).

The junction diagram reflects the last run of Junctions.

Analysis Options

Vehicle length (m)	Calculate Queue Percentiles	Calculate detailed queueing delay	Show lane queues in feet / metres	Show all PICADY stream intercepts	Calculate residual capacity	RFC Threshold	Average Delay threshold (s)	Queue threshold (PCU)	Use iterations with HCM roundabouts	Max number of iterations for roundabouts
5.75						0.85	36.00	20.00		500

Demand Set Summary

ID	Scenario name	Time Period name	Traffic profile type	Start time (HH:mm)	Finish time (HH:mm)	Time segment length (min)	Run automatically
D1	2025 Base	AM	ONE HOUR	06:45	08:15	15	✓
D2	2025 Base	PM	ONE HOUR	15:45	17:15	15	✓
D3	2025 Base + Committed	AM	ONE HOUR	06:45	08:15	15	✓
D4	2025 Base + Committed	PM	ONE HOUR	15:45	17:15	15	✓
D5	2025 Base + Committed + Proposed	AM	ONE HOUR	06:45	08:15	15	✓
D6	2025 Base + Committed + Proposed	PM	ONE HOUR	15:45	17:15	15	✓

Analysis Set Details

ID	Include in report	Network flow scaling factor (%)	Network capacity scaling factor (%)
A1	✓	100.000	100.000

2025 Base, AM

Data Errors and Warnings

Severity	Area	Item	Description
Warning	Large Roundabout	Arm 1 - Large roundabout data	Large Roundabout Circulating Flow is zero for one or more arms.

Junction Network

Junctions

Junction	Name	Junction type	Use circulating lanes	Arm order	Junction Delay (s)	Junction LOS
1	untitled	Large Roundabout		1, 2, 3, 4, 5	27.69	D

Junction Network

Driving side	Lighting	Network delay (s)	Network LOS
Left	Normal/unknown	27.69	D

Arms

Arms

Arm	Name	Description	No give-way line
1	M180 East		
2	A18		
3	M180 West		
4	Barnetby Top		
5	A15		

Roundabout Geometry

Arm	V - Approach road half-width (m)	E - Entry width (m)	I' - Effective flare length (m)	R - Entry radius (m)	D - Inscribed circle diameter (m)	PHI - Conflict (entry) angle (deg)	Entry only	Exit only
1	6.45	7.20	12.2	74.9	158.4	23.2		
2	6.33	7.60	15.7	82.9	162.1	16.0		
3	6.38	7.91	18.4	42.8	153.0	12.0		
4	3.52	5.61	6.7	20.4	157.6	17.5		
5	6.21	6.68	3.2	60.1	159.3	15.2		

Large Roundabout Data

Arm	Circulating flow (PCU/hr)	Has entry-to-exit separation	Entry-to-exit separation (m)
1	0	✓	142.35
2	0	✓	74.51
3	0	✓	135.31
4	0	✓	23.20
5	0	✓	59.36

Slope / Intercept / Capacity

Arm Intercept Adjustments

Arm	Type	Reason	Direct intercept adjustment (PCU/hr)
1	Direct		-278
2	Direct		-610
3	Direct		-670
4	Direct		-280
5	Direct		-390

Roundabout Slope and Intercept used in model

Arm	Final slope	Final intercept (PCU/hr)
1	1.150	2556
2	1.204	2514
3	1.232	2411
4	0.898	1982
5	1.123	2496

The slope and intercept shown above include any corrections and adjustments.

Traffic Demand

Demand Set Details

ID	Scenario name	Time Period name	Traffic profile type	Start time (HH:mm)	Finish time (HH:mm)	Time segment length (min)	Run automatically
D1	2025 Base	AM	ONE HOUR	06:45	08:15	15	✓

Vehicle mix varies over turn	Vehicle mix varies over entry	Vehicle mix source	PCU Factor for a HV (PCU)
✓	✓	HV Percentages	2.00

Demand overview (Traffic)

Arm	Linked arm	Profile type	Use O-D data	Average Demand (PCU/hr)	Scaling Factor (%)
1		ONE HOUR	✓	537	100.000
2		ONE HOUR	✓	854	100.000
3		ONE HOUR	✓	858	100.000
4		ONE HOUR	✓	199	100.000
5		ONE HOUR	✓	1450	100.000

Origin-Destination Data

Demand (PCU/hr)

	To					
	1	2	3	4	5	
From	1	0	62	1	28	446
	2	153	0	311	52	338
	3	2	238	1	46	571
	4	54	39	67	0	39
	5	638	260	531	20	1

Proportions

	To					
	1	2	3	4	5	
From	1	0.00	0.12	0.00	0.05	0.83
	2	0.18	0.00	0.36	0.06	0.40
	3	0.00	0.28	0.00	0.05	0.67
	4	0.27	0.20	0.34	0.00	0.20
	5	0.44	0.18	0.37	0.01	0.00

Vehicle Mix

Heavy Vehicle Percentages

		To				
From		1	2	3	4	5
	1	0	10	0	20	10
	2	7	0	6	2	6
	3	0	14	0	12	10
	4	8	0	13	0	14
	5	10	7	14	11	0

Average PCU Per Veh

		To				
From		1	2	3	4	5
	1	1.000	1.100	1.000	1.200	1.100
	2	1.070	1.000	1.060	1.020	1.060
	3	1.000	1.140	1.000	1.120	1.100
	4	1.080	1.000	1.130	1.000	1.140
	5	1.100	1.070	1.140	1.110	1.000

Detailed Demand Data

Demand for each time segment

Time Segment	Arm	Demand (PCU/hr)	Demand in PCU (PCU/hr)
06:45-07:00	1	404	404
	2	643	643
	3	646	646
	4	150	150
	5	1092	1092
07:00-07:15	1	483	483
	2	768	768
	3	771	771
	4	179	179
	5	1304	1304
07:15-07:30	1	591	591
	2	940	940
	3	945	945
	4	219	219
	5	1596	1596
07:30-07:45	1	591	591
	2	940	940
	3	945	945
	4	219	219
	5	1596	1596
07:45-08:00	1	483	483
	2	768	768
	3	771	771
	4	179	179
	5	1304	1304
08:00-08:15	1	404	404
	2	643	643
	3	646	646
	4	150	150
	5	1092	1092

Results

Results Summary for whole modelled period

Arm	Max RFC	Max Delay (s)	Max Queue (PCU)	Max LOS	Average Demand (PCU/hr)	Total Junction Arrivals (PCU)
1	0.54	7.82	1.3	A	493	739
2	0.88	28.19	6.9	D	784	1175
3	0.94	46.71	11.5	E	787	1181
4	0.84	72.78	4.1	F	183	274
5	0.88	17.32	7.3	C	1331	1996

Main Results for each time segment

06:45 - 07:00

Arm	Total Demand (PCU/hr)	Junction Arrivals (PCU)	Circulating flow (PCU/hr)	Capacity (PCU/hr)	RFC	Throughput (PCU/hr)	Throughput (exit side) (PCU/hr)	Start queue (PCU)	End queue (PCU)	Delay (s)	Unsignalised level of service
1	404	101	867	1559	0.259	403	635	0.0	0.4	3.433	A
2	643	161	821	1526	0.421	640	449	0.0	0.8	4.290	A
3	646	161	778	1453	0.445	642	683	0.0	0.9	4.916	A
4	150	37	1311	805	0.186	149	109	0.0	0.2	5.978	A
5	1092	273	415	2030	0.538	1087	1045	0.0	1.3	4.209	A

07:00 - 07:15

Arm	Total Demand (PCU/hr)	Junction Arrivals (PCU)	Circulating flow (PCU/hr)	Capacity (PCU/hr)	RFC	Throughput (PCU/hr)	Throughput (exit side) (PCU/hr)	Start queue (PCU)	End queue (PCU)	Delay (s)	Unsignalised level of service
1	483	121	1037	1364	0.354	482	759	0.4	0.6	4.502	A
2	768	192	982	1332	0.577	765	537	0.8	1.4	6.700	A
3	771	193	931	1265	0.610	768	816	0.9	1.7	7.996	A
4	179	45	1568	574	0.312	178	131	0.2	0.5	9.889	A
5	1304	326	496	1939	0.672	1300	1250	1.3	2.2	6.210	A

07:15 - 07:30

Arm	Total Demand (PCU/hr)	Junction Arrivals (PCU)	Circulating flow (PCU/hr)	Capacity (PCU/hr)	RFC	Throughput (PCU/hr)	Throughput (exit side) (PCU/hr)	Start queue (PCU)	End queue (PCU)	Delay (s)	Unsignalised level of service
1	591	148	1251	1118	0.529	589	919	0.6	1.2	7.484	A
2	940	235	1193	1077	0.873	922	646	1.4	6.1	22.390	C
3	945	236	1129	1021	0.925	915	987	1.7	9.0	31.701	D
4	219	55	1886	288	0.761	210	158	0.5	2.8	45.879	E
5	1596	399	591	1832	0.871	1579	1505	2.2	6.7	14.830	B

07:30 - 07:45

Arm	Total Demand (PCU/hr)	Junction Arrivals (PCU)	Circulating flow (PCU/hr)	Capacity (PCU/hr)	RFC	Throughput (PCU/hr)	Throughput (exit side) (PCU/hr)	Start queue (PCU)	End queue (PCU)	Delay (s)	Unsignalised level of service
1	591	148	1267	1099	0.538	591	929	1.2	1.3	7.821	A
2	940	235	1203	1066	0.882	937	655	6.1	6.9	28.189	D
3	945	236	1140	1007	0.938	935	999	9.0	11.5	46.711	E
4	219	55	1915	262	0.836	214	160	2.8	4.1	72.779	F
5	1596	399	602	1819	0.878	1594	1527	6.7	7.3	17.323	C

07:45 - 08:00

Arm	Total Demand (PCU/hr)	Junction Arrivals (PCU)	Circulating flow (PCU/hr)	Capacity (PCU/hr)	RFC	Throughput (PCU/hr)	Throughput (exit side) (PCU/hr)	Start queue (PCU)	End queue (PCU)	Delay (s)	Unsignalised level of service
1	483	121	1069	1326	0.364	485	778	1.3	0.6	4.743	A
2	768	192	999	1311	0.586	789	556	6.9	1.5	7.601	A
3	771	193	949	1242	0.621	810	839	11.5	1.9	10.066	B
4	179	45	1624	523	0.342	193	135	4.1	0.6	12.376	B
5	1304	326	524	1907	0.684	1323	1293	7.3	2.5	7.051	A

08:00 - 08:15

Arm	Total Demand (PCU/hr)	Junction Arrivals (PCU)	Circulating flow (PCU/hr)	Capacity (PCU/hr)	RFC	Throughput (PCU/hr)	Throughput (exit side) (PCU/hr)	Start queue (PCU)	End queue (PCU)	Delay (s)	Unsignalised level of service
1	404	101	875	1549	0.261	405	641	0.6	0.4	3.477	A
2	643	161	827	1518	0.424	646	453	1.5	0.8	4.390	A
3	646	161	784	1446	0.447	650	689	1.9	0.9	5.054	A
4	150	37	1324	793	0.189	151	110	0.6	0.3	6.123	A
5	1092	273	420	2024	0.539	1096	1055	2.5	1.3	4.321	A

2025 Base, PM

Data Errors and Warnings

Severity	Area	Item	Description
Warning	Large Roundabout	Arm 1 - Large roundabout data	Large Roundabout Circulating Flow is zero for one or more arms.

Junction Network

Junctions

Junction	Name	Junction type	Use circulating lanes	Arm order	Junction Delay (s)	Junction LOS
1	untitled	Large Roundabout		1, 2, 3, 4, 5	42.12	E

Junction Network

Driving side	Lighting	Network delay (s)	Network LOS
Left	Normal/unknown	42.12	E

Arms

Arms

[same as above]

Roundabout Geometry

[same as above]

Large Roundabout Data

Arm	Circulating flow (PCU/hr)	Has entry-to-exit separation	Entry-to-exit separation (m)
1	0	✓	142.35
2	0	✓	74.51
3	0	✓	135.31
4	0	✓	23.20
5	0	✓	59.36

Slope / Intercept / Capacity

[same as above]

Traffic Demand

Demand Set Details

ID	Scenario name	Time Period name	Traffic profile type	Start time (HH:mm)	Finish time (HH:mm)	Time segment length (min)	Run automatically
D2	2025 Base	PM	ONE HOUR	15:45	17:15	15	✓

Vehicle mix varies over turn	Vehicle mix varies over entry	Vehicle mix source	PCU Factor for a HV (PCU)
✓	✓	HV Percentages	2.00

Demand overview (Traffic)

Arm	Linked arm	Profile type	Use O-D data	Average Demand (PCU/hr)	Scaling Factor (%)
1		ONE HOUR	✓	732	100.000
2		ONE HOUR	✓	657	100.000
3		ONE HOUR	✓	944	100.000
4		ONE HOUR	✓	144	100.000
5		ONE HOUR	✓	1397	100.000

Origin-Destination Data

Demand (PCU/hr)

		To				
		1	2	3	4	5
From	1	0	160	0	11	561
	2	71	1	246	50	289
	3	2	338	1	83	520
	4	25	26	46	0	47
	5	397	445	525	29	1

Proportions

		To				
		1	2	3	4	5
From	1	0.00	0.22	0.00	0.02	0.77
	2	0.11	0.00	0.37	0.08	0.44
	3	0.00	0.36	0.00	0.09	0.55
	4	0.17	0.18	0.32	0.00	0.33
	5	0.28	0.32	0.38	0.02	0.00

Vehicle Mix

Heavy Vehicle Percentages

		To				
		1	2	3	4	5
From	1	0	12	0	10	9
	2	5	0	6	7	4
	3	50	6	0	8	8
	4	29	9	7	0	14
	5	8	4	10	12	0

Average PCU Per Veh

		To				
		1	2	3	4	5
From	1	1.000	1.120	1.000	1.100	1.090
	2	1.050	1.000	1.060	1.070	1.040
	3	1.500	1.060	1.000	1.080	1.080
	4	1.290	1.090	1.070	1.000	1.140
	5	1.080	1.040	1.100	1.120	1.000

Detailed Demand Data

Demand for each time segment

Time Segment	Arm	Demand (PCU/hr)	Demand in PCU (PCU/hr)
15:45-16:00	1	551	551
	2	495	495
	3	711	711
	4	108	108
	5	1052	1052
16:00-16:15	1	658	658
	2	591	591
	3	849	849
	4	129	129
	5	1256	1256
16:15-16:30	1	806	806
	2	723	723
	3	1039	1039
	4	159	159
	5	1538	1538
16:30-16:45	1	806	806
	2	723	723
	3	1039	1039
	4	159	159
	5	1538	1538
16:45-17:00	1	658	658
	2	591	591
	3	849	849
	4	129	129
	5	1256	1256
17:00-17:15	1	551	551
	2	495	495
	3	711	711
	4	108	108
	5	1052	1052

Results

Results Summary for whole modelled period

Arm	Max RFC	Max Delay (s)	Max Queue (PCU)	Max LOS	Average Demand (PCU/hr)	Total Junction Arrivals (PCU)
1	1.04	113.85	27.2	F	672	1008
2	0.72	13.57	2.6	B	603	904
3	0.96	52.27	14.4	F	866	1299
4	0.61	38.46	1.6	E	132	198
5	0.82	11.48	4.8	B	1282	1923

Main Results for each time segment

15:45 - 16:00

Arm	Total Demand (PCU/hr)	Junction Arrivals (PCU)	Circulating flow (PCU/hr)	Capacity (PCU/hr)	RFC	Throughput (PCU/hr)	Throughput (exit side) (PCU/hr)	Start queue (PCU)	End queue (PCU)	Delay (s)	Unsignalised level of service
1	551	138	1058	1339	0.412	548	371	0.0	0.8	4.971	A
2	495	124	880	1455	0.340	493	727	0.0	0.5	3.921	A
3	711	178	759	1477	0.481	707	613	0.0	1.0	4.993	A
4	108	27	1336	782	0.139	108	130	0.0	0.2	6.024	A
5	1052	263	382	2067	0.509	1047	1062	0.0	1.1	3.781	A

16:00 - 16:15

Arm	Total Demand (PCU/hr)	Junction Arrivals (PCU)	Circulating flow (PCU/hr)	Capacity (PCU/hr)	RFC	Throughput (PCU/hr)	Throughput (exit side) (PCU/hr)	Start queue (PCU)	End queue (PCU)	Delay (s)	Unsignalised level of service
1	658	165	1266	1101	0.598	655	444	0.8	1.6	8.787	A
2	591	148	1051	1248	0.473	589	869	0.5	0.9	5.728	A
3	849	212	907	1294	0.656	845	733	1.0	2.0	8.518	A
4	129	32	1597	548	0.236	129	155	0.2	0.3	9.672	A
5	1256	314	456	1983	0.633	1253	1269	1.1	1.8	5.280	A

16:15 - 16:30

Arm	Total Demand (PCU/hr)	Junction Arrivals (PCU)	Circulating flow (PCU/hr)	Capacity (PCU/hr)	RFC	Throughput (PCU/hr)	Throughput (exit side) (PCU/hr)	Start queue (PCU)	End queue (PCU)	Delay (s)	Unsignalised level of service
1	806	201	1533	793	1.016	748	541	1.6	16.1	58.003	F
2	723	181	1242	1019	0.710	717	1039	0.9	2.5	12.313	B
3	1039	260	1066	1098	0.946	1005	893	2.0	10.6	33.329	D
4	159	40	1885	289	0.548	155	186	0.3	1.3	29.518	D
5	1538	385	546	1882	0.817	1527	1494	1.8	4.5	10.590	B

16:30 - 16:45

Arm	Total Demand (PCU/hr)	Junction Arrivals (PCU)	Circulating flow (PCU/hr)	Capacity (PCU/hr)	RFC	Throughput (PCU/hr)	Throughput (exit side) (PCU/hr)	Start queue (PCU)	End queue (PCU)	Delay (s)	Unsignalised level of service
1	806	201	1548	776	1.039	762	544	16.1	27.2	113.852	F
2	723	181	1257	1000	0.723	723	1052	2.5	2.6	13.566	B
3	1039	260	1080	1081	0.962	1024	900	10.6	14.4	52.268	F
4	159	40	1916	261	0.607	157	188	1.3	1.6	38.461	E
5	1538	385	555	1872	0.822	1537	1518	4.5	4.8	11.482	B

16:45 - 17:00

Arm	Total Demand (PCU/hr)	Junction Arrivals (PCU)	Circulating flow (PCU/hr)	Capacity (PCU/hr)	RFC	Throughput (PCU/hr)	Throughput (exit side) (PCU/hr)	Start queue (PCU)	End queue (PCU)	Delay (s)	Unsignalised level of service
1	658	165	1296	1065	0.618	759	450	27.2	1.8	17.702	C
2	591	148	1141	1141	0.518	597	915	2.6	1.1	7.028	A
3	849	212	994	1187	0.715	895	743	14.4	2.8	15.179	C
4	129	32	1727	431	0.300	134	162	1.6	0.5	13.894	B
5	1256	314	479	1958	0.642	1267	1382	4.8	2.0	5.691	A

17:00 - 17:15

Arm	Total Demand (PCU/hr)	Junction Arrivals (PCU)	Circulating flow (PCU/hr)	Capacity (PCU/hr)	RFC	Throughput (PCU/hr)	Throughput (exit side) (PCU/hr)	Start queue (PCU)	End queue (PCU)	Delay (s)	Unsignalised level of service
1	551	138	1069	1327	0.415	555	374	1.8	0.8	5.141	A
2	495	124	889	1444	0.343	497	735	1.1	0.6	4.007	A
3	711	178	768	1466	0.485	718	618	2.8	1.0	5.213	A
4	108	27	1354	766	0.142	110	131	0.5	0.2	6.211	A
5	1052	263	388	2060	0.511	1055	1076	2.0	1.1	3.863	A

2025 Base + Committed, AM

Data Errors and Warnings

Severity	Area	Item	Description
Warning	Large Roundabout	Arm 1 - Large roundabout data	Large Roundabout Circulating Flow is zero for one or more arms.

Junction Network

Junctions

Junction	Name	Junction type	Use circulating lanes	Arm order	Junction Delay (s)	Junction LOS
1	untitled	Large Roundabout		1, 2, 3, 4, 5	69.84	F

Junction Network

Driving side	Lighting	Network delay (s)	Network LOS
Left	Normal/unknown	69.84	F

Arms

Arms

[same as above]

Roundabout Geometry

[same as above]

Large Roundabout Data

Arm	Circulating flow (PCU/hr)	Has entry-to-exit separation	Entry-to-exit separation (m)
1	0	✓	142.35
2	0	✓	74.51
3	0	✓	135.31
4	0	✓	23.20
5	0	✓	59.36

Slope / Intercept / Capacity

[same as above]

Traffic Demand

Demand Set Details

ID	Scenario name	Time Period name	Traffic profile type	Start time (HH:mm)	Finish time (HH:mm)	Time segment length (min)	Run automatically
D3	2025 Base + Committed	AM	ONE HOUR	06:45	08:15	15	✓

Vehicle mix varies over turn	Vehicle mix varies over entry	Vehicle mix source	PCU Factor for a HV (PCU)
✓	✓	HV Percentages	2.00

Demand overview (Traffic)

Arm	Linked arm	Profile type	Use O-D data	Average Demand (PCU/hr)	Scaling Factor (%)
1		ONE HOUR	✓	537	100.000
2		ONE HOUR	✓	874	100.000
3		ONE HOUR	✓	858	100.000
4		ONE HOUR	✓	222	100.000
5		ONE HOUR	✓	1555	100.000

Origin-Destination Data

Demand (PCU/hr)

		To				
		1	2	3	4	5
From	1	0	62	1	28	446
	2	173	0	311	52	338
	3	2	238	1	46	571
	4	77	39	67	0	39
	5	659	260	531	20	85

Proportions

		To				
		1	2	3	4	5
From	1	0.00	0.12	0.00	0.05	0.83
	2	0.20	0.00	0.36	0.06	0.39
	3	0.00	0.28	0.00	0.05	0.67
	4	0.35	0.18	0.30	0.00	0.18
	5	0.42	0.17	0.34	0.01	0.05

Vehicle Mix

Heavy Vehicle Percentages

		To				
		1	2	3	4	5
From	1	0	10	0	20	10
	2	7	0	6	2	6
	3	0	14	0	12	10
	4	8	0	13	0	14
	5	10	7	14	11	0

Average PCU Per Veh

		To				
		1	2	3	4	5
From	1	1.000	1.100	1.000	1.200	1.100
	2	1.070	1.000	1.060	1.020	1.060
	3	1.000	1.140	1.000	1.120	1.100
	4	1.080	1.000	1.130	1.000	1.140
	5	1.100	1.070	1.140	1.110	1.000

Detailed Demand Data

Demand for each time segment

Time Segment	Arm	Demand (PCU/hr)	Demand in PCU (PCU/hr)
06:45-07:00	1	404	404
	2	658	658
	3	646	646
	4	167	167
	5	1171	1171
07:00-07:15	1	483	483
	2	786	786
	3	771	771
	4	200	200
	5	1398	1398
07:15-07:30	1	591	591
	2	962	962
	3	945	945
	4	244	244
	5	1712	1712
07:30-07:45	1	591	591
	2	962	962
	3	945	945
	4	244	244
	5	1712	1712
07:45-08:00	1	483	483
	2	786	786
	3	771	771
	4	200	200
	5	1398	1398
08:00-08:15	1	404	404
	2	658	658
	3	646	646
	4	167	167
	5	1171	1171

Results

Results Summary for whole modelled period

Arm	Max RFC	Max Delay (s)	Max Queue (PCU)	Max LOS	Average Demand (PCU/hr)	Total Junction Arrivals (PCU)
1	0.57	9.07	1.5	A	493	739
2	1.00	74.55	20.0	F	802	1203
3	1.07	134.11	38.6	F	787	1181
4	1.10	215.30	15.3	F	204	306
5	0.94	31.95	14.3	D	1427	2140

Main Results for each time segment

06:45 - 07:00

Arm	Total Demand (PCU/hr)	Junction Arrivals (PCU)	Circulating flow (PCU/hr)	Capacity (PCU/hr)	RFC	Throughput (PCU/hr)	Throughput (exit side) (PCU/hr)	Start queue (PCU)	End queue (PCU)	Delay (s)	Unsignalised level of service
1	404	101	929	1488	0.272	403	682	0.0	0.4	3.660	A
2	658	164	883	1450	0.454	655	448	0.0	0.9	4.771	A
3	646	161	856	1358	0.476	642	682	0.0	1.0	5.560	A
4	167	42	1388	735	0.227	166	109	0.0	0.3	6.871	A
5	1171	293	447	1994	0.587	1164	1108	0.0	1.5	4.749	A

07:00 - 07:15

Arm	Total Demand (PCU/hr)	Junction Arrivals (PCU)	Circulating flow (PCU/hr)	Capacity (PCU/hr)	RFC	Throughput (PCU/hr)	Throughput (exit side) (PCU/hr)	Start queue (PCU)	End queue (PCU)	Delay (s)	Unsignalised level of service
1	483	121	1110	1279	0.377	482	815	0.4	0.7	4.979	A
2	786	196	1056	1242	0.633	782	536	0.9	1.8	8.224	A
3	771	193	1023	1151	0.670	767	815	1.0	2.2	10.271	B
4	200	50	1659	492	0.406	198	131	0.3	0.7	13.255	B
5	1398	349	533	1897	0.737	1392	1324	1.5	3.0	7.775	A

07:15 - 07:30

Arm	Total Demand (PCU/hr)	Junction Arrivals (PCU)	Circulating flow (PCU/hr)	Capacity (PCU/hr)	RFC	Throughput (PCU/hr)	Throughput (exit side) (PCU/hr)	Start queue (PCU)	End queue (PCU)	Delay (s)	Unsignalised level of service
1	591	148	1310	1049	0.564	588	968	0.7	1.4	8.574	A
2	962	241	1272	982	0.980	916	627	1.8	13.3	42.426	E
3	945	236	1223	906	1.043	868	965	2.2	21.4	63.769	F
4	244	61	1937	242	1.008	216	153	0.7	8.0	102.810	F
5	1712	428	603	1819	0.941	1676	1550	3.0	12.0	23.502	C

07:30 - 07:45

Arm	Total Demand (PCU/hr)	Junction Arrivals (PCU)	Circulating flow (PCU/hr)	Capacity (PCU/hr)	RFC	Throughput (PCU/hr)	Throughput (exit side) (PCU/hr)	Start queue (PCU)	End queue (PCU)	Delay (s)	Unsignalised level of service
1	591	148	1328	1029	0.575	591	983	1.4	1.5	9.068	A
2	962	241	1285	966	0.996	936	634	13.3	20.0	74.550	F
3	945	236	1239	885	1.067	876	981	21.4	38.6	134.113	F
4	244	61	1960	222	1.102	215	155	8.0	15.3	215.304	F
5	1712	428	608	1812	0.945	1703	1566	12.0	14.3	31.953	D

07:45 - 08:00

Arm	Total Demand (PCU/hr)	Junction Arrivals (PCU)	Circulating flow (PCU/hr)	Capacity (PCU/hr)	RFC	Throughput (PCU/hr)	Throughput (exit side) (PCU/hr)	Start queue (PCU)	End queue (PCU)	Delay (s)	Unsignalised level of service
1	483	121	1204	1172	0.412	485	869	1.5	0.8	5.820	A
2	786	196	1095	1195	0.657	857	594	20.0	2.1	13.731	B
3	771	193	1078	1084	0.712	914	874	38.6	3.0	41.852	E
4	200	50	1848	322	0.619	253	144	15.3	2.0	80.281	F
5	1398	349	635	1783	0.784	1438	1466	14.3	4.2	12.713	B

08:00 - 08:15

Arm	Total Demand (PCU/hr)	Junction Arrivals (PCU)	Circulating flow (PCU/hr)	Capacity (PCU/hr)	RFC	Throughput (PCU/hr)	Throughput (exit side) (PCU/hr)	Start queue (PCU)	End queue (PCU)	Delay (s)	Unsignalised level of service
1	404	101	946	1469	0.275	406	694	0.8	0.4	3.748	A
2	658	164	895	1436	0.458	663	456	2.1	0.9	4.964	A
3	646	161	865	1346	0.480	654	693	3.0	1.0	5.841	A
4	167	42	1408	718	0.233	174	111	2.0	0.3	7.294	A
5	1171	293	458	1981	0.591	1181	1123	4.2	1.6	5.024	A

2025 Base + Committed, PM

Data Errors and Warnings

Severity	Area	Item	Description
Warning	Large Roundabout	Arm 1 - Large roundabout data	Large Roundabout Circulating Flow is zero for one or more arms.

Junction Network

Junctions

Junction	Name	Junction type	Use circulating lanes	Arm order	Junction Delay (s)	Junction LOS
1	untitled	Large Roundabout		1, 2, 3, 4, 5	58.10	F

Junction Network

Driving side	Lighting	Network delay (s)	Network LOS
Left	Normal/unknown	58.10	F

Arms

Arms

[same as above]

Roundabout Geometry

[same as above]

Large Roundabout Data

Arm	Circulating flow (PCU/hr)	Has entry-to-exit separation	Entry-to-exit separation (m)
1	0	✓	142.35
2	0	✓	74.51
3	0	✓	135.31
4	0	✓	23.20
5	0	✓	59.36

Slope / Intercept / Capacity

[same as above]

Traffic Demand

Demand Set Details

ID	Scenario name	Time Period name	Traffic profile type	Start time (HH:mm)	Finish time (HH:mm)	Time segment length (min)	Run automatically
D4	2025 Base + Committed	PM	ONE HOUR	15:45	17:15	15	✓

Vehicle mix varies over turn	Vehicle mix varies over entry	Vehicle mix source	PCU Factor for a HV (PCU)
✓	✓	HV Percentages	2.00

Demand overview (Traffic)

Arm	Linked arm	Profile type	Use O-D data	Average Demand (PCU/hr)	Scaling Factor (%)
1		ONE HOUR	✓	770	100.000
2		ONE HOUR	✓	657	100.000
3		ONE HOUR	✓	944	100.000
4		ONE HOUR	✓	144	100.000
5		ONE HOUR	✓	1411	100.000

Origin-Destination Data

Demand (PCU/hr)

		To				
		1	2	3	4	5
From	1	0	172	0	24	574
	2	71	1	246	50	289
	3	2	338	1	83	520
	4	25	26	46	0	47
	5	397	445	525	29	15

Proportions

		To				
		1	2	3	4	5
From	1	0.00	0.22	0.00	0.03	0.75
	2	0.11	0.00	0.37	0.08	0.44
	3	0.00	0.36	0.00	0.09	0.55
	4	0.17	0.18	0.32	0.00	0.33
	5	0.28	0.32	0.37	0.02	0.01

Vehicle Mix

Heavy Vehicle Percentages

		To				
		1	2	3	4	5
From	1	0	12	0	10	9
	2	5	0	6	7	4
	3	50	6	0	8	8
	4	29	9	7	0	14
	5	8	4	10	12	0

Average PCU Per Veh

		To				
		1	2	3	4	5
From	1	1.000	1.120	1.000	1.100	1.090
	2	1.050	1.000	1.060	1.070	1.040
	3	1.500	1.060	1.000	1.080	1.080
	4	1.290	1.090	1.070	1.000	1.140
	5	1.080	1.040	1.100	1.120	1.000

Detailed Demand Data

Demand for each time segment

Time Segment	Arm	Demand (PCU/hr)	Demand in PCU (PCU/hr)
15:45-16:00	1	580	580
	2	495	495
	3	711	711
	4	108	108
	5	1062	1062
16:00-16:15	1	692	692
	2	591	591
	3	849	849
	4	129	129
	5	1268	1268
16:15-16:30	1	848	848
	2	723	723
	3	1039	1039
	4	159	159
	5	1554	1554
16:30-16:45	1	848	848
	2	723	723
	3	1039	1039
	4	159	159
	5	1554	1554
16:45-17:00	1	692	692
	2	591	591
	3	849	849
	4	129	129
	5	1268	1268
17:00-17:15	1	580	580
	2	495	495
	3	711	711
	4	108	108
	5	1062	1062

Results

Results Summary for whole modelled period

Arm	Max RFC	Max Delay (s)	Max Queue (PCU)	Max LOS	Average Demand (PCU/hr)	Total Junction Arrivals (PCU)
1	1.12	184.47	49.2	F	707	1060
2	0.73	13.96	2.7	B	603	904
3	0.97	57.90	16.0	F	866	1299
4	0.59	36.68	1.5	E	132	198
5	0.83	12.00	5.0	B	1295	1942

Main Results for each time segment

15:45 - 16:00

Arm	Total Demand (PCU/hr)	Junction Arrivals (PCU)	Circulating flow (PCU/hr)	Capacity (PCU/hr)	RFC	Throughput (PCU/hr)	Throughput (exit side) (PCU/hr)	Start queue (PCU)	End queue (PCU)	Delay (s)	Unsignalised level of service
1	580	145	1069	1327	0.437	576	371	0.0	0.8	5.236	A
2	495	124	909	1419	0.349	492	736	0.0	0.6	4.072	A
3	711	178	789	1440	0.494	707	613	0.0	1.0	5.238	A
4	108	27	1356	764	0.142	108	139	0.0	0.2	6.188	A
5	1062	266	382	2067	0.514	1058	1082	0.0	1.1	3.815	A

16:00 - 16:15

Arm	Total Demand (PCU/hr)	Junction Arrivals (PCU)	Circulating flow (PCU/hr)	Capacity (PCU/hr)	RFC	Throughput (PCU/hr)	Throughput (exit side) (PCU/hr)	Start queue (PCU)	End queue (PCU)	Delay (s)	Unsignalised level of service
1	692	173	1278	1087	0.637	688	444	0.8	1.9	9.817	A
2	591	148	1087	1205	0.490	589	879	0.6	1.0	6.119	A
3	849	212	942	1251	0.678	844	733	1.0	2.2	9.389	A
4	129	32	1620	527	0.246	129	166	0.2	0.4	10.187	B
5	1268	317	456	1983	0.640	1265	1292	1.1	1.9	5.365	A

16:15 - 16:30

Arm	Total Demand (PCU/hr)	Junction Arrivals (PCU)	Circulating flow (PCU/hr)	Capacity (PCU/hr)	RFC	Throughput (PCU/hr)	Throughput (exit side) (PCU/hr)	Start queue (PCU)	End queue (PCU)	Delay (s)	Unsignalised level of service
1	848	212	1546	778	1.089	752	540	1.9	25.8	82.044	F
2	723	181	1256	1001	0.723	717	1041	1.0	2.6	13.034	B
3	1039	260	1081	1081	0.962	1000	893	2.2	12.1	37.109	E
4	159	40	1883	291	0.545	155	198	0.4	1.3	29.171	D
5	1554	388	544	1884	0.824	1542	1494	1.9	4.7	10.951	B

16:30 - 16:45

Arm	Total Demand (PCU/hr)	Junction Arrivals (PCU)	Circulating flow (PCU/hr)	Capacity (PCU/hr)	RFC	Throughput (PCU/hr)	Throughput (exit side) (PCU/hr)	Start queue (PCU)	End queue (PCU)	Delay (s)	Unsignalised level of service
1	848	212	1563	758	1.118	754	544	25.8	49.2	184.472	F
2	723	181	1263	993	0.729	723	1054	2.6	2.7	13.958	B
3	1039	260	1086	1073	0.968	1024	900	12.1	16.0	57.897	F
4	159	40	1910	267	0.594	157	200	1.3	1.5	36.677	E
5	1554	388	555	1872	0.830	1552	1512	4.7	5.0	12.004	B

16:45 - 17:00

Arm	Total Demand (PCU/hr)	Junction Arrivals (PCU)	Circulating flow (PCU/hr)	Capacity (PCU/hr)	RFC	Throughput (PCU/hr)	Throughput (exit side) (PCU/hr)	Start queue (PCU)	End queue (PCU)	Delay (s)	Unsignalised level of service
1	692	173	1309	1051	0.658	880	450	49.2	2.3	51.461	F
2	591	148	1243	1017	0.581	596	945	2.7	1.5	9.083	A
3	849	212	1096	1062	0.799	894	743	16.0	4.7	27.387	D
4	129	32	1812	355	0.365	133	178	1.5	0.7	18.614	C
5	1268	317	478	1959	0.647	1281	1467	5.0	2.0	5.797	A

17:00 - 17:15

Arm	Total Demand (PCU/hr)	Junction Arrivals (PCU)	Circulating flow (PCU/hr)	Capacity (PCU/hr)	RFC	Throughput (PCU/hr)	Throughput (exit side) (PCU/hr)	Start queue (PCU)	End queue (PCU)	Delay (s)	Unsignalised level of service
1	580	145	1082	1312	0.442	585	374	2.3	0.9	5.476	A
2	495	124	920	1406	0.352	498	747	1.5	0.6	4.185	A
3	711	178	800	1427	0.498	725	619	4.7	1.1	5.621	A
4	108	27	1383	740	0.146	110	142	0.7	0.2	6.476	A
5	1062	266	391	2057	0.517	1066	1102	2.0	1.2	3.917	A

2025 Base + Committed + Proposed, AM

Data Errors and Warnings

Severity	Area	Item	Description
Warning	Large Roundabout	Arm 1 - Large roundabout data	Large Roundabout Circulating Flow is zero for one or more arms.

Junction Network

Junctions

Junction	Name	Junction type	Use circulating lanes	Arm order	Junction Delay (s)	Junction LOS
1	untitled	Large Roundabout		1, 2, 3, 4, 5	78.07	F

Junction Network

Driving side	Lighting	Network delay (s)	Network LOS
Left	Normal/unknown	78.07	F

Arms

Arms

[same as above]

Roundabout Geometry

[same as above]

Large Roundabout Data

Arm	Circulating flow (PCU/hr)	Has entry-to-exit separation	Entry-to-exit separation (m)
1	0	✓	142.35
2	0	✓	74.51
3	0	✓	135.31
4	0	✓	23.20
5	0	✓	59.36

Slope / Intercept / Capacity

[same as above]

Traffic Demand

Demand Set Details

ID	Scenario name	Time Period name	Traffic profile type	Start time (HH:mm)	Finish time (HH:mm)	Time segment length (min)	Run automatically
D5	2025 Base + Committed + Proposed	AM	ONE HOUR	06:45	08:15	15	✓

Vehicle mix varies over turn	Vehicle mix varies over entry	Vehicle mix source	PCU Factor for a HV (PCU)
✓	✓	HV Percentages	2.00

Demand overview (Traffic)

Arm	Linked arm	Profile type	Use O-D data	Average Demand (PCU/hr)	Scaling Factor (%)
1		ONE HOUR	✓	537	100.000
2		ONE HOUR	✓	874	100.000
3		ONE HOUR	✓	858	100.000
4		ONE HOUR	✓	222	100.000
5		ONE HOUR	✓	1638	100.000

Origin-Destination Data

Demand (PCU/hr)

		To				
		1	2	3	4	5
From	1	0	62	1	28	446
	2	173	0	311	52	338
	3	2	238	1	46	571
	4	77	39	67	0	39
	5	742	260	531	20	85

Proportions

		To				
		1	2	3	4	5
From	1	0.00	0.12	0.00	0.05	0.83
	2	0.20	0.00	0.36	0.06	0.39
	3	0.00	0.28	0.00	0.05	0.67
	4	0.35	0.18	0.30	0.00	0.18
	5	0.45	0.16	0.32	0.01	0.05

Vehicle Mix

Heavy Vehicle Percentages

		To				
		1	2	3	4	5
From	1	0	10	0	20	10
	2	7	0	6	2	6
	3	0	14	0	12	10
	4	8	0	13	0	14
	5	10	7	14	11	0

Average PCU Per Veh

		To				
		1	2	3	4	5
From	1	1.000	1.100	1.000	1.200	1.100
	2	1.070	1.000	1.060	1.020	1.060
	3	1.000	1.140	1.000	1.120	1.100
	4	1.080	1.000	1.130	1.000	1.140
	5	1.100	1.070	1.140	1.110	1.000

Detailed Demand Data

Demand for each time segment

Time Segment	Arm	Demand (PCU/hr)	Demand in PCU (PCU/hr)
06:45-07:00	1	404	404
	2	658	658
	3	646	646
	4	167	167
	5	1233	1233
07:00-07:15	1	483	483
	2	786	786
	3	771	771
	4	200	200
	5	1473	1473
07:15-07:30	1	591	591
	2	962	962
	3	945	945
	4	244	244
	5	1803	1803
07:30-07:45	1	591	591
	2	962	962
	3	945	945
	4	244	244
	5	1803	1803
07:45-08:00	1	483	483
	2	786	786
	3	771	771
	4	200	200
	5	1473	1473
08:00-08:15	1	404	404
	2	658	658
	3	646	646
	4	167	167
	5	1233	1233

Results

Results Summary for whole modelled period

Arm	Max RFC	Max Delay (s)	Max Queue (PCU)	Max LOS	Average Demand (PCU/hr)	Total Junction Arrivals (PCU)
1	0.57	8.76	1.4	A	493	739
2	0.98	66.77	17.6	F	802	1203
3	1.07	136.09	39.3	F	787	1181
4	1.10	216.11	15.4	F	204	306
5	1.00	57.72	28.7	F	1503	2255

Main Results for each time segment

06:45 - 07:00

Arm	Total Demand (PCU/hr)	Junction Arrivals (PCU)	Circulating flow (PCU/hr)	Capacity (PCU/hr)	RFC	Throughput (PCU/hr)	Throughput (exit side) (PCU/hr)	Start queue (PCU)	End queue (PCU)	Delay (s)	Unsignalised level of service
1	404	101	929	1488	0.272	403	744	0.0	0.4	3.659	A
2	658	164	883	1451	0.454	655	448	0.0	0.9	4.770	A
3	646	161	856	1358	0.476	642	682	0.0	1.0	5.560	A
4	167	42	1388	735	0.227	166	109	0.0	0.3	6.871	A
5	1233	308	447	1994	0.618	1226	1108	0.0	1.8	5.122	A

07:00 - 07:15

Arm	Total Demand (PCU/hr)	Junction Arrivals (PCU)	Circulating flow (PCU/hr)	Capacity (PCU/hr)	RFC	Throughput (PCU/hr)	Throughput (exit side) (PCU/hr)	Start queue (PCU)	End queue (PCU)	Delay (s)	Unsignalised level of service
1	483	121	1109	1280	0.377	482	889	0.4	0.7	4.973	A
2	786	196	1056	1243	0.632	782	536	0.9	1.8	8.213	A
3	771	193	1023	1152	0.670	767	815	1.0	2.2	10.268	B
4	200	50	1659	492	0.405	198	131	0.3	0.7	13.252	B
5	1473	368	533	1897	0.776	1465	1324	1.8	3.7	9.032	A

07:15 - 07:30

Arm	Total Demand (PCU/hr)	Junction Arrivals (PCU)	Circulating flow (PCU/hr)	Capacity (PCU/hr)	RFC	Throughput (PCU/hr)	Throughput (exit side) (PCU/hr)	Start queue (PCU)	End queue (PCU)	Delay (s)	Unsignalised level of service
1	591	148	1294	1068	0.554	589	1046	0.7	1.3	8.249	A
2	962	241	1261	996	0.966	921	622	1.8	12.0	39.175	E
3	945	236	1224	904	1.045	866	958	2.2	21.8	64.557	F
4	244	61	1937	242	1.010	215	153	0.7	8.0	103.338	F
5	1803	451	603	1818	0.992	1737	1550	3.7	20.4	34.380	D

07:30 - 07:45

Arm	Total Demand (PCU/hr)	Junction Arrivals (PCU)	Circulating flow (PCU/hr)	Capacity (PCU/hr)	RFC	Throughput (PCU/hr)	Throughput (exit side) (PCU/hr)	Start queue (PCU)	End queue (PCU)	Delay (s)	Unsignalised level of service
1	591	148	1314	1045	0.566	591	1064	1.3	1.4	8.758	A
2	962	241	1276	978	0.984	940	630	12.0	17.6	66.775	F
3	945	236	1241	883	1.069	875	975	21.8	39.3	136.090	F
4	244	61	1960	222	1.103	215	155	8.0	15.4	216.113	F
5	1803	451	609	1812	0.995	1770	1566	20.4	28.7	57.719	F

07:45 - 08:00

Arm	Total Demand (PCU/hr)	Junction Arrivals (PCU)	Circulating flow (PCU/hr)	Capacity (PCU/hr)	RFC	Throughput (PCU/hr)	Throughput (exit side) (PCU/hr)	Start queue (PCU)	End queue (PCU)	Delay (s)	Unsignalised level of service
1	483	121	1232	1139	0.424	485	966	1.4	0.8	6.103	A
2	786	196	1114	1172	0.670	847	603	17.6	2.2	13.939	B
3	771	193	1074	1088	0.709	917	887	39.3	2.9	41.904	E
4	200	50	1847	323	0.617	253	144	15.4	2.0	79.864	F
5	1473	368	634	1784	0.826	1565	1466	28.7	5.7	23.802	C

08:00 - 08:15

Arm	Total Demand (PCU/hr)	Junction Arrivals (PCU)	Circulating flow (PCU/hr)	Capacity (PCU/hr)	RFC	Throughput (PCU/hr)	Throughput (exit side) (PCU/hr)	Start queue (PCU)	End queue (PCU)	Delay (s)	Unsignalised level of service
1	404	101	948	1466	0.276	406	759	0.8	0.4	3.759	A
2	658	164	897	1434	0.459	663	457	2.2	0.9	4.985	A
3	646	161	866	1345	0.480	653	695	2.9	1.0	5.843	A
4	167	42	1408	717	0.233	174	111	2.0	0.3	7.301	A
5	1233	308	458	1981	0.622	1249	1124	5.7	1.8	5.527	A

2025 Base + Committed + Proposed, PM

Data Errors and Warnings

Severity	Area	Item	Description
Warning	Large Roundabout	Arm 1 - Large roundabout data	Large Roundabout Circulating Flow is zero for one or more arms.

Junction Network

Junctions

Junction	Name	Junction type	Use circulating lanes	Arm order	Junction Delay (s)	Junction LOS
1	untitled	Large Roundabout		1, 2, 3, 4, 5	17.18	C

Junction Network

Driving side	Lighting	Network delay (s)	Network LOS
Left	Normal/unknown	17.18	C

Arms

Arms

[same as above]

Roundabout Geometry

[same as above]

Large Roundabout Data

Arm	Circulating flow (PCU/hr)	Has entry-to-exit separation	Entry-to-exit separation (m)
1	0	✓	142.35
2	0	✓	74.51
3	0	✓	135.31
4	0	✓	23.20
5	0	✓	59.36

Slope / Intercept / Capacity

[same as above]

Traffic Demand

Demand Set Details

ID	Scenario name	Time Period name	Traffic profile type	Start time (HH:mm)	Finish time (HH:mm)	Time segment length (min)	Run automatically
D6	2025 Base + Committed + Proposed	PM	ONE HOUR	15:45	17:15	15	✓

Vehicle mix varies over turn	Vehicle mix varies over entry	Vehicle mix source	PCU Factor for a HV (PCU)
✓	✓	HV Percentages	2.00

Demand overview (Traffic)

Arm	Linked arm	Profile type	Use O-D data	Average Demand (PCU/hr)	Scaling Factor (%)
1		ONE HOUR	✓	853	100.000
2		ONE HOUR	✓	657	100.000
3		ONE HOUR	✓	606	100.000
4		ONE HOUR	✓	144	100.000
5		ONE HOUR	✓	1411	100.000

Origin-Destination Data

Demand (PCU/hr)

		To				
		1	2	3	4	5
From	1	0	172	0	24	657
	2	71	1	246	50	289
	3	2	0	1	83	520
	4	25	26	46	0	47
	5	397	445	525	29	15

Proportions

		To				
		1	2	3	4	5
From	1	0.00	0.20	0.00	0.03	0.77
	2	0.11	0.00	0.37	0.08	0.44
	3	0.00	0.00	0.00	0.14	0.86
	4	0.17	0.18	0.32	0.00	0.33
	5	0.28	0.32	0.37	0.02	0.01

Vehicle Mix

Heavy Vehicle Percentages

		To				
		1	2	3	4	5
From	1	0	12	0	10	9
	2	5	0	6	7	4
	3	50	6	0	8	8
	4	29	9	7	0	14
	5	8	4	10	12	0

Average PCU Per Veh

		To				
		1	2	3	4	5
From	1	1.000	1.120	1.000	1.100	1.090
	2	1.050	1.000	1.060	1.070	1.040
	3	1.500	1.060	1.000	1.080	1.080
	4	1.290	1.090	1.070	1.000	1.140
	5	1.080	1.040	1.100	1.120	1.000

Detailed Demand Data

Demand for each time segment

Time Segment	Arm	Demand (PCU/hr)	Demand in PCU (PCU/hr)
15:45-16:00	1	642	642
	2	495	495
	3	456	456
	4	108	108
	5	1062	1062
16:00-16:15	1	767	767
	2	591	591
	3	545	545
	4	129	129
	5	1268	1268
16:15-16:30	1	939	939
	2	723	723
	3	667	667
	4	159	159
	5	1554	1554
16:30-16:45	1	939	939
	2	723	723
	3	667	667
	4	159	159
	5	1554	1554
16:45-17:00	1	767	767
	2	591	591
	3	545	545
	4	129	129
	5	1268	1268
17:00-17:15	1	642	642
	2	495	495
	3	456	456
	4	108	108
	5	1062	1062

Results

Results Summary for whole modelled period

Arm	Max RFC	Max Delay (s)	Max Queue (PCU)	Max LOS	Average Demand (PCU/hr)	Total Junction Arrivals (PCU)
1	0.80	16.30	4.1	C	783	1174
2	0.91	43.52	8.2	E	603	904
3	0.76	18.30	3.3	C	556	834
4	0.35	14.04	0.6	B	132	198
5	0.68	5.29	2.3	A	1295	1942

Main Results for each time segment

15:45 - 16:00

Arm	Total Demand (PCU/hr)	Junction Arrivals (PCU)	Circulating flow (PCU/hr)	Capacity (PCU/hr)	RFC	Throughput (PCU/hr)	Throughput (exit side) (PCU/hr)	Start queue (PCU)	End queue (PCU)	Delay (s)	Unsignalised level of service
1	642	161	816	1617	0.397	639	371	0.0	0.7	4.024	A
2	495	124	973	1343	0.368	492	483	0.0	0.6	4.434	A
3	456	114	851	1363	0.335	454	613	0.0	0.5	4.271	A
4	108	27	1166	935	0.116	108	139	0.0	0.1	4.915	A
5	1062	266	129	2351	0.452	1059	1145	0.0	0.9	2.986	A

16:00 - 16:15

Arm	Total Demand (PCU/hr)	Junction Arrivals (PCU)	Circulating flow (PCU/hr)	Capacity (PCU/hr)	RFC	Throughput (PCU/hr)	Throughput (exit side) (PCU/hr)	Start queue (PCU)	End queue (PCU)	Delay (s)	Unsignalised level of service
1	767	192	977	1433	0.535	765	444	0.7	1.2	5.888	A
2	591	148	1164	1113	0.531	588	578	0.6	1.2	7.183	A
3	545	136	1018	1157	0.471	543	734	0.5	0.9	6.318	A
4	129	32	1395	730	0.177	129	167	0.1	0.2	6.768	A
5	1268	317	154	2322	0.546	1267	1370	0.9	1.3	3.659	A

16:15 - 16:30

Arm	Total Demand (PCU/hr)	Junction Arrivals (PCU)	Circulating flow (PCU/hr)	Capacity (PCU/hr)	RFC	Throughput (PCU/hr)	Throughput (exit side) (PCU/hr)	Start queue (PCU)	End queue (PCU)	Delay (s)	Unsignalised level of service
1	939	235	1195	1182	0.794	928	541	1.2	3.9	14.962	B
2	723	181	1418	807	0.896	701	705	1.2	6.7	31.107	D
3	667	167	1228	898	0.743	659	891	0.9	2.9	15.783	C
4	159	40	1686	468	0.339	157	202	0.2	0.6	13.045	B
5	1554	388	186	2287	0.679	1550	1657	1.3	2.2	5.221	A

16:30 - 16:45

Arm	Total Demand (PCU/hr)	Junction Arrivals (PCU)	Circulating flow (PCU/hr)	Capacity (PCU/hr)	RFC	Throughput (PCU/hr)	Throughput (exit side) (PCU/hr)	Start queue (PCU)	End queue (PCU)	Delay (s)	Unsignalised level of service
1	939	235	1198	1179	0.797	938	544	3.9	4.1	16.305	C
2	723	181	1427	795	0.910	717	709	6.7	8.2	43.519	E
3	667	167	1246	876	0.761	666	898	2.9	3.3	18.297	C
4	159	40	1708	448	0.354	158	204	0.6	0.6	14.036	B
5	1554	388	189	2284	0.680	1553	1678	2.2	2.3	5.293	A

16:45 - 17:00

Arm	Total Demand (PCU/hr)	Junction Arrivals (PCU)	Circulating flow (PCU/hr)	Capacity (PCU/hr)	RFC	Throughput (PCU/hr)	Throughput (exit side) (PCU/hr)	Start queue (PCU)	End queue (PCU)	Delay (s)	Unsignalised level of service
1	767	192	982	1427	0.537	778	449	4.1	1.3	6.183	A
2	591	148	1177	1097	0.539	618	583	8.2	1.2	8.356	A
3	545	136	1048	1121	0.486	554	748	3.3	1.0	6.964	A
4	129	32	1430	697	0.186	131	171	0.6	0.3	7.198	A
5	1268	317	159	2317	0.547	1272	1403	2.3	1.3	3.712	A

17:00 - 17:15

Arm	Total Demand (PCU/hr)	Junction Arrivals (PCU)	Circulating flow (PCU/hr)	Capacity (PCU/hr)	RFC	Throughput (PCU/hr)	Throughput (exit side) (PCU/hr)	Start queue (PCU)	End queue (PCU)	Delay (s)	Unsignalised level of service
1	642	161	821	1612	0.398	644	373	1.3	0.7	4.087	A
2	495	124	979	1335	0.371	497	486	1.2	0.6	4.527	A
3	456	114	859	1354	0.337	458	618	1.0	0.6	4.353	A
4	108	27	1176	926	0.117	109	141	0.3	0.2	4.983	A
5	1062	266	130	2350	0.452	1064	1155	1.3	0.9	3.013	A

Junctions 10
ARCADY 10 - Roundabout Module
Version: 10.0.4.1693 © Copyright TRL Software Limited, 2021
For sales and distribution information, program advice and maintenance, contact TRL Software: +44 (0)1344 379777 software@trl.co.uk trlsoftware.com
The users of this computer program for the solution of an engineering problem are in no way relieved of their responsibility for the correctness of the solution

Filename: J5 A1060_A1733_HumberRd.j10

Path: \\na.aecomnet.com\lfs\EMEA\Leeds-UKLDS2\Legacy\UKLDS2PFPSW001\WIP\LE_Projects\Newproje\60668866 - Humber Zero\400_Technical\Traffic & Transport\NH Comments 10.01.24\Junction Modelling\Modelling May 2024

Report generation date: 10/05/2024 07:56:27

- »2025 Base, AM
- »2025 Base, PM
- »2025 Base + Committed, AM
- »2025 Base + Committed, PM
- »2025 Base + Committed + Proposed, AM
- »2025 Base + Committed + Proposed, PM

Summary of junction performance

	AM					PM				
	Set ID	Queue (PCU)	Delay (s)	RFC	LOS	Set ID	Queue (PCU)	Delay (s)	RFC	LOS
2025 Base										
Arm 1	D1	0.4	2.92	0.17	A	D2	0.7	3.00	0.34	A
Arm 2		0.4	1.96	0.22	A		0.2	1.95	0.14	A
Arm 3		0.0	0.00	0.00	A		0.0	4.48	0.01	A
Arm 4		0.5	2.85	0.27	A		0.4	2.59	0.21	A
Arm 5		0.0	1.71	0.00	A		0.0	0.00	0.00	A
2025 Base + Committed										
Arm 1	D3	0.4	2.88	0.18	A	D4	1.0	3.38	0.42	A
Arm 2		0.5	2.11	0.27	A		0.2	2.12	0.15	A
Arm 3		0.0	0.00	0.00	A		0.0	4.93	0.01	A
Arm 4		0.6	3.26	0.32	A		0.5	2.83	0.24	A
Arm 5		0.0	1.89	0.00	A		0.0	0.00	0.00	A
2025 Base + Committed + Proposed										
Arm 1	D5	0.4	2.97	0.18	A	D6	1.0	3.47	0.42	A
Arm 2		0.5	2.11	0.27	A		0.2	2.14	0.16	A
Arm 3		0.0	0.00	0.00	A		0.0	4.98	0.01	A
Arm 4		0.7	3.33	0.33	A		0.5	2.82	0.25	A
Arm 5		0.0	1.94	0.00	A		0.0	0.00	0.00	A

Values shown are the highest values encountered over all time segments. Delay is the maximum value of average delay per arriving vehicle.

File summary

File Description

Title	
Location	
Site number	
Date	17/01/2024
Version	
Status	(new file)
Identifier	
Client	
Jobnumber	
Enumerator	NA\SimmonsA1
Description	

Units

Distance units	Speed units	Traffic units input	Traffic units results	Flow units	Average delay units	Total delay units	Rate of delay units
m	kph	PCU	PCU	perHour	s	-Min	perMin

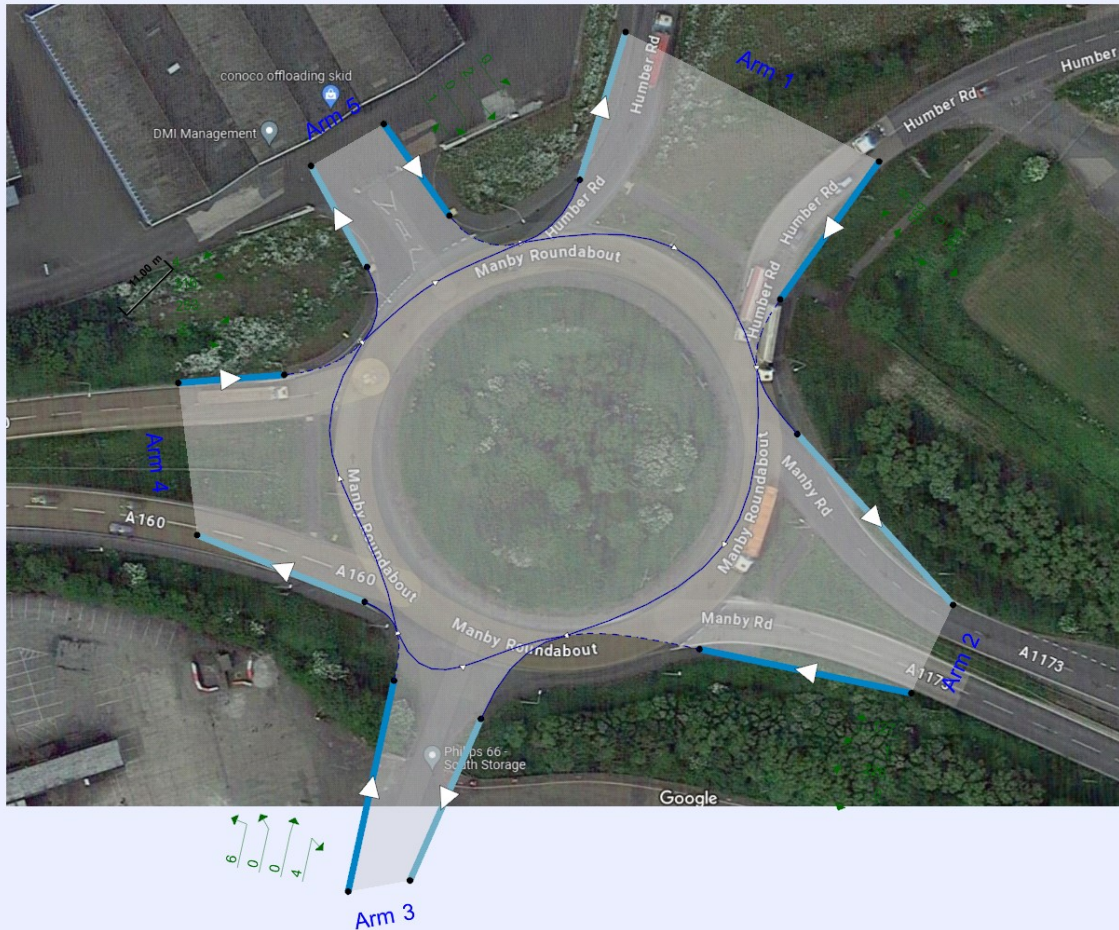

Flows show original traffic demand (PCU/hr).

The junction diagram reflects the last run of Junctions.

Analysis Options

Calculate Queue Percentiles	Calculate residual capacity	RFC Threshold	Average Delay threshold (s)	Queue threshold (PCU)
		0.85	36.00	20.00

Demand Set Summary

ID	Scenario name	Time Period name	Traffic profile type	Start time (HH:mm)	Finish time (HH:mm)	Time segment length (min)
D1	2025 Base	AM	ONE HOUR	06:45	08:15	15
D2	2025 Base	PM	ONE HOUR	15:45	17:15	15
D3	2025 Base + Committed	AM	ONE HOUR	06:45	08:15	15
D4	2025 Base + Committed	PM	ONE HOUR	15:45	17:15	15
D5	2025 Base + Committed + Proposed	AM	ONE HOUR	06:45	08:15	15
D6	2025 Base + Committed + Proposed	PM	ONE HOUR	15:45	17:15	15

Analysis Set Details

ID	Network flow scaling factor (%)
A1	100.000

2025 Base, AM

Data Errors and Warnings

No errors or warnings

Junction Network

Junctions

Junction	Name	Junction type	Use circulating lanes	Arm order	Junction Delay (s)	Junction LOS
1	A1060 A1733 Humber Road	Standard Roundabout		1, 2, 3, 4, 5	2.53	A

Junction Network

Driving side	Lighting	Network delay (s)	Network LOS
Left	Normal/unknown	2.53	A

Arms

Arms

Arm	Name	Description	No give-way line
1	Humber Road		
2	Manby Road		
3	Phillips 66		
4	A160 West		
5	Conoco Access		

Roundabout Geometry

Arm	V - Approach road half-width (m)	E - Entry width (m)	I' - Effective flare length (m)	R - Entry radius (m)	D - Inscribed circle diameter (m)	PHI - Conflict (entry) angle (deg)	Entry only	Exit only
1	7.01	7.85	22.3	35.0	85.6	36.0		
2	7.11	8.73	4.4	57.3	85.6	30.0		
3	2.98	8.16	4.6	17.2	85.6	33.0		
4	6.38	8.73	1.6	21.0	85.6	41.0		
5	7.83	8.15	15.0	9.7	85.6	52.0		

Slope / Intercept / Capacity

Roundabout Slope and Intercept used in model

Arm	Enter slope and intercept directly	Entered slope	Entered intercept (PCU/hr)	Final slope	Final intercept (PCU/hr)
1	✓	1.096	2872	1.096	2872
2	✓	1.238	3347	1.238	3347
3	✓	0.761	1981	0.761	1981
4	✓	1.033	2777	1.033	2777
5	✓	1.050	3186	1.050	3186

The slope and intercept shown above include any corrections and adjustments.

Traffic Demand

Demand Set Details

ID	Scenario name	Time Period name	Traffic profile type	Start time (HH:mm)	Finish time (HH:mm)	Time segment length (min)
D1	2025 Base	AM	ONE HOUR	06:45	08:15	15

Vehicle mix source	PCU Factor for a HV (PCU)
HV Percentages	2.00

Demand overview (Traffic)

Arm	Linked arm	Use O-D data	Average Demand (PCU/hr)	Scaling Factor (%)
1		✓	399	100.000
2		✓	587	100.000
3		✓	0	100.000
4		✓	576	100.000
5		✓	6	100.000

Origin-Destination Data

Demand (PCU/hr)

		To				
		1	2	3	4	5
From	1	13	61	0	324	1
	2	345	0	0	241	1
	3	0	0	0	0	0
	4	383	188	2	0	3
	5	4	0	0	2	0

Vehicle Mix

Heavy Vehicle Percentages

		To				
		1	2	3	4	5
From	1	42	38	100	92	0
	2	22	67	100	22	0
	3	100	0	0	0	0
	4	48	19	100	67	100
	5	0	0	0	0	0

Detailed Demand Data

Demand for each time segment

Time Segment	Arm	Demand (PCU/hr)	Demand in PCU (PCU/hr)
06:45-07:00	1	300	300
	2	442	442
	3	0	0
	4	434	434
	5	5	5
07:00-07:15	1	359	359
	2	528	528
	3	0	0
	4	518	518
	5	5	5
07:15-07:30	1	439	439
	2	646	646
	3	0	0
	4	634	634
	5	7	7
07:30-07:45	1	439	439
	2	646	646
	3	0	0
	4	634	634
	5	7	7
07:45-08:00	1	359	359
	2	528	528
	3	0	0
	4	518	518
	5	5	5
08:00-08:15	1	300	300
	2	442	442
	3	0	0
	4	434	434
	5	5	5

Results

Results Summary for whole modelled period

Arm	Max RFC	Max Delay (s)	Max Queue (PCU)	Max LOS
1	0.17	2.92	0.4	A
2	0.22	1.96	0.4	A
3	0.00	0.00	0.0	A
4	0.27	2.85	0.5	A
5	0.00	1.71	0.0	A

Main Results for each time segment

06:45 - 07:00

Arm	Total Demand (PCU/hr)	Circulating flow (PCU/hr)	Capacity (PCU/hr)	RFC	Throughput (PCU/hr)	End queue (PCU)	Delay (s)	Unsignalised level of service
1	300	144	2714	0.111	300	0.2	2.666	A
2	442	257	3029	0.146	441	0.2	1.696	A
3	0	696	1451	0.000	0	0.0	0.000	A
4	434	271	2498	0.174	432	0.3	2.393	A
5	5	699	2452	0.002	5	0.0	1.470	A

07:00 - 07:15

Arm	Total Demand (PCU/hr)	Circulating flow (PCU/hr)	Capacity (PCU/hr)	RFC	Throughput (PCU/hr)	End queue (PCU)	Delay (s)	Unsignalised level of service
1	359	172	2683	0.134	358	0.3	2.769	A
2	528	307	2967	0.178	527	0.3	1.799	A
3	0	833	1347	0.000	0	0.0	0.000	A
4	518	323	2443	0.212	517	0.4	2.568	A
5	5	836	2308	0.002	5	0.0	1.562	A

07:15 - 07:30

Arm	Total Demand (PCU/hr)	Circulating flow (PCU/hr)	Capacity (PCU/hr)	RFC	Throughput (PCU/hr)	End queue (PCU)	Delay (s)	Unsignalised level of service
1	439	211	2641	0.166	439	0.4	2.924	A
2	646	376	2881	0.224	646	0.4	1.964	A
3	0	1020	1205	0.000	0	0.0	0.000	A
4	634	396	2368	0.268	634	0.5	2.852	A
5	7	1024	2110	0.003	7	0.0	1.710	A

07:30 - 07:45

Arm	Total Demand (PCU/hr)	Circulating flow (PCU/hr)	Capacity (PCU/hr)	RFC	Throughput (PCU/hr)	End queue (PCU)	Delay (s)	Unsignalised level of service
1	439	211	2640	0.166	439	0.4	2.924	A
2	646	377	2881	0.224	646	0.4	1.964	A
3	0	1021	1204	0.000	0	0.0	0.000	A
4	634	396	2368	0.268	634	0.5	2.852	A
5	7	1025	2110	0.003	7	0.0	1.710	A

07:45 - 08:00

Arm	Total Demand (PCU/hr)	Circulating flow (PCU/hr)	Capacity (PCU/hr)	RFC	Throughput (PCU/hr)	End queue (PCU)	Delay (s)	Unsignalised level of service
1	359	173	2683	0.134	359	0.3	2.770	A
2	528	308	2966	0.178	528	0.3	1.802	A
3	0	834	1346	0.000	0	0.0	0.000	A
4	518	324	2442	0.212	518	0.4	2.572	A
5	5	838	2306	0.002	5	0.0	1.563	A

08:00 - 08:15

Arm	Total Demand (PCU/hr)	Circulating flow (PCU/hr)	Capacity (PCU/hr)	RFC	Throughput (PCU/hr)	End queue (PCU)	Delay (s)	Unsignalised level of service
1	300	145	2713	0.111	301	0.2	2.667	A
2	442	258	3028	0.146	442	0.2	1.697	A
3	0	698	1450	0.000	0	0.0	0.000	A
4	434	271	2497	0.174	434	0.3	2.399	A
5	5	701	2450	0.002	5	0.0	1.471	A

2025 Base, PM

Data Errors and Warnings

No errors or warnings

Junction Network

Junctions

Junction	Name	Junction type	Use circulating lanes	Arm order	Junction Delay (s)	Junction LOS
1	A1060 A1733 Humber Road	Standard Roundabout		1, 2, 3, 4, 5	2.66	A

Junction Network

Driving side	Lighting	Network delay (s)	Network LOS
Left	Normal/unknown	2.66	A

Traffic Demand

Demand Set Details

ID	Scenario name	Time Period name	Traffic profile type	Start time (HH:mm)	Finish time (HH:mm)	Time segment length (min)
D2	2025 Base	PM	ONE HOUR	15:45	17:15	15

Vehicle mix source	PCU Factor for a HV (PCU)
HV Percentages	2.00

Demand overview (Traffic)

Arm	Linked arm	Use O-D data	Average Demand (PCU/hr)	Scaling Factor (%)
1		✓	792	100.000
2		✓	344	100.000
3		✓	10	100.000
4		✓	489	100.000
5		✓	3	100.000

Origin-Destination Data

Demand (PCU/hr)

		To				
		1	2	3	4	5
From	1	51	316	0	425	0
	2	120	0	0	223	1
	3	0	4	0	6	0
	4	233	250	2	0	4
	5	0	2	0	1	0

Vehicle Mix

Heavy Vehicle Percentages

		To				
From		1	2	3	4	5
	1	37	21	0	61	0
	2	37	9	100	20	0
	3	0	50	0	67	0
	4	91	20	75	40	100
	5	0	0	0	100	0

Detailed Demand Data

Demand for each time segment

Time Segment	Arm	Demand (PCU/hr)	Demand in PCU (PCU/hr)
15:45-16:00	1	596	596
	2	259	259
	3	8	8
	4	368	368
	5	0	0
16:00-16:15	1	712	712
	2	309	309
	3	9	9
	4	440	440
	5	0	0
16:15-16:30	1	872	872
	2	379	379
	3	11	11
	4	538	538
	5	0	0
16:30-16:45	1	872	872
	2	379	379
	3	11	11
	4	538	538
	5	0	0
16:45-17:00	1	712	712
	2	309	309
	3	9	9
	4	440	440
	5	0	0
17:00-17:15	1	596	596
	2	259	259
	3	8	8
	4	368	368
	5	0	0

Results

Results Summary for whole modelled period

Arm	Max RFC	Max Delay (s)	Max Queue (PCU)	Max LOS
1	0.34	3.00	0.7	A
2	0.14	1.95	0.2	A
3	0.01	4.48	0.0	A
4	0.21	2.59	0.4	A
5	0.00	0.00	0.0	A

Main Results for each time segment

15:45 - 16:00

Arm	Total Demand (PCU/hr)	Circulating flow (PCU/hr)	Capacity (PCU/hr)	RFC	Throughput (PCU/hr)	End queue (PCU)	Delay (s)	Unsignalised level of service
1	596	192	2661	0.224	595	0.4	2.453	A
2	259	359	2903	0.089	258	0.1	1.706	A
3	8	616	1512	0.005	7	0.0	3.820	A
4	368	132	2640	0.139	367	0.2	2.321	A
5	0	496	2666	0.000	0	0.0	0.000	A

16:00 - 16:15

Arm	Total Demand (PCU/hr)	Circulating flow (PCU/hr)	Capacity (PCU/hr)	RFC	Throughput (PCU/hr)	End queue (PCU)	Delay (s)	Unsignalised level of service
1	712	230	2620	0.272	712	0.5	2.656	A
2	309	429	2815	0.110	309	0.2	1.799	A
3	9	737	1420	0.006	9	0.0	4.074	A
4	440	158	2614	0.168	439	0.3	2.427	A
5	0	593	2563	0.000	0	0.0	0.000	A

16:15 - 16:30

Arm	Total Demand (PCU/hr)	Circulating flow (PCU/hr)	Capacity (PCU/hr)	RFC	Throughput (PCU/hr)	End queue (PCU)	Delay (s)	Unsignalised level of service
1	872	282	2563	0.340	871	0.7	2.994	A
2	379	526	2696	0.140	379	0.2	1.947	A
3	11	902	1294	0.009	11	0.0	4.480	A
4	538	194	2577	0.209	538	0.4	2.589	A
5	0	726	2424	0.000	0	0.0	0.000	A

16:30 - 16:45

Arm	Total Demand (PCU/hr)	Circulating flow (PCU/hr)	Capacity (PCU/hr)	RFC	Throughput (PCU/hr)	End queue (PCU)	Delay (s)	Unsignalised level of service
1	872	282	2563	0.340	872	0.7	2.997	A
2	379	526	2695	0.141	379	0.2	1.947	A
3	11	903	1294	0.009	11	0.0	4.482	A
4	538	194	2577	0.209	538	0.4	2.589	A
5	0	727	2423	0.000	0	0.0	0.000	A

16:45 - 17:00

Arm	Total Demand (PCU/hr)	Circulating flow (PCU/hr)	Capacity (PCU/hr)	RFC	Throughput (PCU/hr)	End queue (PCU)	Delay (s)	Unsignalised level of service
1	712	230	2620	0.272	713	0.5	2.661	A
2	309	430	2814	0.110	309	0.2	1.803	A
3	9	738	1420	0.006	9	0.0	4.078	A
4	440	158	2613	0.168	440	0.3	2.430	A
5	0	594	2563	0.000	0	0.0	0.000	A

17:00 - 17:15

Arm	Total Demand (PCU/hr)	Circulating flow (PCU/hr)	Capacity (PCU/hr)	RFC	Throughput (PCU/hr)	End queue (PCU)	Delay (s)	Unsignalised level of service
1	596	193	2661	0.224	597	0.4	2.458	A
2	259	360	2901	0.089	259	0.1	1.709	A
3	8	618	1511	0.005	8	0.0	3.827	A
4	368	133	2640	0.139	368	0.2	2.325	A
5	0	497	2664	0.000	0	0.0	0.000	A

2025 Base + Committed, AM

Data Errors and Warnings

No errors or warnings

Junction Network

Junctions

Junction	Name	Junction type	Use circulating lanes	Arm order	Junction Delay (s)	Junction LOS
1	A1060 A1733 Humber Road	Standard Roundabout		1, 2, 3, 4, 5	2.71	A

Junction Network

Driving side	Lighting	Network delay (s)	Network LOS
Left	Normal/unknown	2.71	A

Traffic Demand

Demand Set Details

ID	Scenario name	Time Period name	Traffic profile type	Start time (HH:mm)	Finish time (HH:mm)	Time segment length (min)
D3	2025 Base + Committed	AM	ONE HOUR	06:45	08:15	15

Vehicle mix source	PCU Factor for a HV (PCU)
HV Percentages	2.00

Demand overview (Traffic)

Arm	Linked arm	Use O-D data	Average Demand (PCU/hr)	Scaling Factor (%)
1		✓	423	100.000
2		✓	700	100.000
3		✓	0	100.000
4		✓	636	100.000
5		✓	6	100.000

Origin-Destination Data

Demand (PCU/hr)

		To				
		1	2	3	4	5
From	1	13	61	4	326	19
	2	456	0	0	243	1
	3	0	0	0	0	0
	4	434	197	2	0	3
	5	4	0	0	2	0

Vehicle Mix

Heavy Vehicle Percentages

		To				
		1	2	3	4	5
From	1	42	38	100	92	0
	2	22	67	100	22	0
	3	100	0	0	0	0
	4	48	19	100	67	100
	5	0	0	0	0	0

Detailed Demand Data

Demand for each time segment

Time Segment	Arm	Demand (PCU/hr)	Demand in PCU (PCU/hr)
06:45-07:00	1	318	318
	2	527	527
	3	0	0
	4	479	479
	5	5	5
07:00-07:15	1	380	380
	2	629	629
	3	0	0
	4	572	572
	5	5	5
07:15-07:30	1	466	466
	2	771	771
	3	0	0
	4	700	700
	5	7	7
07:30-07:45	1	466	466
	2	771	771
	3	0	0
	4	700	700
	5	7	7
07:45-08:00	1	380	380
	2	629	629
	3	0	0
	4	572	572
	5	5	5
08:00-08:15	1	318	318
	2	527	527
	3	0	0
	4	479	479
	5	5	5

Results

Results Summary for whole modelled period

Arm	Max RFC	Max Delay (s)	Max Queue (PCU)	Max LOS
1	0.18	2.88	0.4	A
2	0.27	2.11	0.5	A
3	0.00	0.00	0.0	A
4	0.32	3.26	0.6	A
5	0.00	1.89	0.0	A

Main Results for each time segment

06:45 - 07:00

Arm	Total Demand (PCU/hr)	Circulating flow (PCU/hr)	Capacity (PCU/hr)	RFC	Throughput (PCU/hr)	End queue (PCU)	Delay (s)	Unsignalised level of service
1	318	151	2707	0.118	318	0.2	2.611	A
2	527	275	3007	0.175	526	0.3	1.769	A
3	0	796	1375	0.000	0	0.0	0.000	A
4	479	367	2397	0.200	477	0.3	2.584	A
5	5	828	2317	0.002	5	0.0	1.556	A

07:00 - 07:15

Arm	Total Demand (PCU/hr)	Circulating flow (PCU/hr)	Capacity (PCU/hr)	RFC	Throughput (PCU/hr)	End queue (PCU)	Delay (s)	Unsignalised level of service
1	380	181	2674	0.142	380	0.3	2.718	A
2	629	329	2940	0.214	629	0.3	1.899	A
3	0	952	1256	0.000	0	0.0	0.000	A
4	572	439	2323	0.246	571	0.4	2.833	A
5	5	990	2146	0.003	5	0.0	1.680	A

07:15 - 07:30

Arm	Total Demand (PCU/hr)	Circulating flow (PCU/hr)	Capacity (PCU/hr)	RFC	Throughput (PCU/hr)	End queue (PCU)	Delay (s)	Unsignalised level of service
1	466	221	2630	0.177	465	0.4	2.881	A
2	771	403	2848	0.271	770	0.5	2.112	A
3	0	1166	1093	0.000	0	0.0	0.000	A
4	700	538	2221	0.315	700	0.6	3.260	A
5	7	1212	1913	0.003	7	0.0	1.887	A

07:30 - 07:45

Arm	Total Demand (PCU/hr)	Circulating flow (PCU/hr)	Capacity (PCU/hr)	RFC	Throughput (PCU/hr)	End queue (PCU)	Delay (s)	Unsignalised level of service
1	466	221	2629	0.177	466	0.4	2.881	A
2	771	403	2848	0.271	771	0.5	2.113	A
3	0	1167	1093	0.000	0	0.0	0.000	A
4	700	538	2221	0.315	700	0.6	3.263	A
5	7	1213	1912	0.003	7	0.0	1.888	A

07:45 - 08:00

Arm	Total Demand (PCU/hr)	Circulating flow (PCU/hr)	Capacity (PCU/hr)	RFC	Throughput (PCU/hr)	End queue (PCU)	Delay (s)	Unsignalised level of service
1	380	181	2674	0.142	381	0.3	2.721	A
2	629	329	2939	0.214	630	0.3	1.903	A
3	0	954	1255	0.000	0	0.0	0.000	A
4	572	440	2323	0.246	572	0.5	2.838	A
5	5	992	2145	0.003	5	0.0	1.681	A

08:00 - 08:15

Arm	Total Demand (PCU/hr)	Circulating flow (PCU/hr)	Capacity (PCU/hr)	RFC	Throughput (PCU/hr)	End queue (PCU)	Delay (s)	Unsignalised level of service
1	318	151	2706	0.118	319	0.2	2.614	A
2	527	276	3006	0.175	527	0.3	1.773	A
3	0	799	1373	0.000	0	0.0	0.000	A
4	479	368	2396	0.200	479	0.3	2.588	A
5	5	830	2314	0.002	5	0.0	1.560	A

2025 Base + Committed, PM

Data Errors and Warnings

No errors or warnings

Junction Network

Junctions

Junction	Name	Junction type	Use circulating lanes	Arm order	Junction Delay (s)	Junction LOS
1	A1060 A1733 Humber Road	Standard Roundabout		1, 2, 3, 4, 5	2.99	A

Junction Network

Driving side	Lighting	Network delay (s)	Network LOS
Left	Normal/unknown	2.99	A

Traffic Demand

Demand Set Details

ID	Scenario name	Time Period name	Traffic profile type	Start time (HH:mm)	Finish time (HH:mm)	Time segment length (min)
D4	2025 Base + Committed	PM	ONE HOUR	15:45	17:15	15

Vehicle mix source	PCU Factor for a HV (PCU)
HV Percentages	2.00

Demand overview (Traffic)

Arm	Linked arm	Use O-D data	Average Demand (PCU/hr)	Scaling Factor (%)
1		✓	970	100.000
2		✓	350	100.000
3		✓	10	100.000
4		✓	565	100.000
5		✓	3	100.000

Origin-Destination Data

Demand (PCU/hr)

		To				
		1	2	3	4	5
From	1	51	358	4	532	25
	2	123	0	0	226	1
	3	0	4	0	6	0
	4	306	253	2	0	4
	5	0	2	0	1	0

Vehicle Mix

Heavy Vehicle Percentages

		To				
From		1	2	3	4	5
	1	37	21	0	61	0
	2	37	9	100	20	0
	3	0	50	0	67	0
	4	91	20	75	40	100
	5	0	0	0	100	0

Detailed Demand Data

Demand for each time segment

Time Segment	Arm	Demand (PCU/hr)	Demand in PCU (PCU/hr)
15:45-16:00	1	730	730
	2	263	263
	3	8	8
	4	425	425
	5	0	0
16:00-16:15	1	872	872
	2	315	315
	3	9	9
	4	508	508
	5	0	0
16:15-16:30	1	1068	1068
	2	385	385
	3	11	11
	4	622	622
	5	0	0
16:30-16:45	1	1068	1068
	2	385	385
	3	11	11
	4	622	622
	5	0	0
16:45-17:00	1	872	872
	2	315	315
	3	9	9
	4	508	508
	5	0	0
17:00-17:15	1	730	730
	2	263	263
	3	8	8
	4	425	425
	5	0	0

Results

Results Summary for whole modelled period

Arm	Max RFC	Max Delay (s)	Max Queue (PCU)	Max LOS
1	0.42	3.38	1.0	A
2	0.15	2.12	0.2	A
3	0.01	4.93	0.0	A
4	0.24	2.83	0.5	A
5	0.00	0.00	0.0	A

Main Results for each time segment

15:45 - 16:00

Arm	Total Demand (PCU/hr)	Circulating flow (PCU/hr)	Capacity (PCU/hr)	RFC	Throughput (PCU/hr)	End queue (PCU)	Delay (s)	Unsignalised level of service
1	730	194	2659	0.275	728	0.5	2.609	A
2	263	461	2776	0.095	263	0.1	1.795	A
3	8	719	1434	0.005	7	0.0	4.032	A
4	425	153	2619	0.162	424	0.3	2.475	A
5	0	555	2603	0.000	0	0.0	0.000	A

16:00 - 16:15

Arm	Total Demand (PCU/hr)	Circulating flow (PCU/hr)	Capacity (PCU/hr)	RFC	Throughput (PCU/hr)	End queue (PCU)	Delay (s)	Unsignalised level of service
1	872	233	2617	0.333	871	0.7	2.889	A
2	315	552	2664	0.118	314	0.2	1.921	A
3	9	861	1326	0.007	9	0.0	4.366	A
4	508	183	2588	0.196	508	0.4	2.613	A
5	0	664	2489	0.000	0	0.0	0.000	A

16:15 - 16:30

Arm	Total Demand (PCU/hr)	Circulating flow (PCU/hr)	Capacity (PCU/hr)	RFC	Throughput (PCU/hr)	End queue (PCU)	Delay (s)	Unsignalised level of service
1	1068	285	2560	0.417	1067	1.0	3.374	A
2	385	675	2511	0.153	385	0.2	2.123	A
3	11	1054	1179	0.009	11	0.0	4.923	A
4	622	224	2545	0.244	622	0.5	2.825	A
5	0	813	2332	0.000	0	0.0	0.000	A

16:30 - 16:45

Arm	Total Demand (PCU/hr)	Circulating flow (PCU/hr)	Capacity (PCU/hr)	RFC	Throughput (PCU/hr)	End queue (PCU)	Delay (s)	Unsignalised level of service
1	1068	285	2559	0.417	1068	1.0	3.379	A
2	385	676	2510	0.154	385	0.2	2.124	A
3	11	1055	1178	0.009	11	0.0	4.926	A
4	622	225	2545	0.244	622	0.5	2.826	A
5	0	814	2332	0.000	0	0.0	0.000	A

16:45 - 17:00

Arm	Total Demand (PCU/hr)	Circulating flow (PCU/hr)	Capacity (PCU/hr)	RFC	Throughput (PCU/hr)	End queue (PCU)	Delay (s)	Unsignalised level of service
1	872	233	2617	0.333	873	0.7	2.893	A
2	315	553	2663	0.118	315	0.2	1.924	A
3	9	862	1325	0.007	9	0.0	4.370	A
4	508	184	2587	0.196	508	0.4	2.614	A
5	0	665	2488	0.000	0	0.0	0.000	A

17:00 - 17:15

Arm	Total Demand (PCU/hr)	Circulating flow (PCU/hr)	Capacity (PCU/hr)	RFC	Throughput (PCU/hr)	End queue (PCU)	Delay (s)	Unsignalised level of service
1	730	195	2658	0.275	731	0.5	2.618	A
2	263	463	2774	0.095	264	0.1	1.797	A
3	8	722	1432	0.005	8	0.0	4.038	A
4	425	154	2618	0.162	426	0.3	2.481	A
5	0	557	2601	0.000	0	0.0	0.000	A

2025 Base + Committed + Proposed, AM

Data Errors and Warnings

No errors or warnings

Junction Network

Junctions

Junction	Name	Junction type	Use circulating lanes	Arm order	Junction Delay (s)	Junction LOS
1	A1060 A1733 Humber Road	Standard Roundabout		1, 2, 3, 4, 5	2.77	A

Junction Network

Driving side	Lighting	Network delay (s)	Network LOS
Left	Normal/unknown	2.77	A

Traffic Demand

Demand Set Details

ID	Scenario name	Time Period name	Traffic profile type	Start time (HH:mm)	Finish time (HH:mm)	Time segment length (min)
D5	2025 Base + Committed + Proposed	AM	ONE HOUR	06:45	08:15	15

Vehicle mix source	PCU Factor for a HV (PCU)
HV Percentages	2.00

Demand overview (Traffic)

Arm	Linked arm	Use O-D data	Average Demand (PCU/hr)	Scaling Factor (%)
1		✓	423	100.000
2		✓	702	100.000
3		✓	0	100.000
4		✓	677	100.000
5		✓	6	100.000

Origin-Destination Data

Demand (PCU/hr)

		To				
		1	2	3	4	5
From	1	13	65	0	344	1
	2	458	0	0	243	1
	3	0	0	0	0	0
	4	477	197	0	0	3
	5	4	0	0	2	0

Vehicle Mix

Heavy Vehicle Percentages

		To				
		1	2	3	4	5
From	1	42	38	100	92	0
	2	22	67	100	22	0
	3	100	0	0	0	0
	4	48	19	100	67	100
	5	0	0	0	0	0

Detailed Demand Data

Demand for each time segment

Time Segment	Arm	Demand (PCU/hr)	Demand in PCU (PCU/hr)
06:45-07:00	1	318	318
	2	529	529
	3	0	0
	4	510	510
	5	5	5
07:00-07:15	1	380	380
	2	631	631
	3	0	0
	4	609	609
	5	5	5
07:15-07:30	1	466	466
	2	773	773
	3	0	0
	4	745	745
	5	7	7
07:30-07:45	1	466	466
	2	773	773
	3	0	0
	4	745	745
	5	7	7
07:45-08:00	1	380	380
	2	631	631
	3	0	0
	4	609	609
	5	5	5
08:00-08:15	1	318	318
	2	529	529
	3	0	0
	4	510	510
	5	5	5

Results

Results Summary for whole modelled period

Arm	Max RFC	Max Delay (s)	Max Queue (PCU)	Max LOS
1	0.18	2.97	0.4	A
2	0.27	2.11	0.5	A
3	0.00	0.00	0.0	A
4	0.33	3.33	0.7	A
5	0.00	1.94	0.0	A

Main Results for each time segment

06:45 - 07:00

Arm	Total Demand (PCU/hr)	Circulating flow (PCU/hr)	Capacity (PCU/hr)	RFC	Throughput (PCU/hr)	End queue (PCU)	Delay (s)	Unsignalised level of service
1	318	149	2708	0.118	318	0.2	2.692	A
2	529	270	3012	0.175	527	0.3	1.766	A
3	0	798	1374	0.000	0	0.0	0.000	A
4	510	355	2410	0.212	508	0.4	2.619	A
5	5	860	2283	0.002	5	0.0	1.579	A

07:00 - 07:15

Arm	Total Demand (PCU/hr)	Circulating flow (PCU/hr)	Capacity (PCU/hr)	RFC	Throughput (PCU/hr)	End queue (PCU)	Delay (s)	Unsignalised level of service
1	380	179	2676	0.142	380	0.3	2.804	A
2	631	323	2947	0.214	631	0.3	1.895	A
3	0	954	1255	0.000	0	0.0	0.000	A
4	609	425	2338	0.260	608	0.5	2.879	A
5	5	1029	2106	0.003	5	0.0	1.713	A

07:15 - 07:30

Arm	Total Demand (PCU/hr)	Circulating flow (PCU/hr)	Capacity (PCU/hr)	RFC	Throughput (PCU/hr)	End queue (PCU)	Delay (s)	Unsignalised level of service
1	466	219	2632	0.177	465	0.4	2.972	A
2	773	396	2857	0.271	772	0.5	2.106	A
3	0	1169	1092	0.000	0	0.0	0.000	A
4	745	520	2239	0.333	745	0.7	3.330	A
5	7	1260	1863	0.004	7	0.0	1.938	A

07:30 - 07:45

Arm	Total Demand (PCU/hr)	Circulating flow (PCU/hr)	Capacity (PCU/hr)	RFC	Throughput (PCU/hr)	End queue (PCU)	Delay (s)	Unsignalised level of service
1	466	219	2632	0.177	466	0.4	2.972	A
2	773	396	2856	0.271	773	0.5	2.107	A
3	0	1169	1091	0.000	0	0.0	0.000	A
4	745	521	2239	0.333	745	0.7	3.333	A
5	7	1261	1862	0.004	7	0.0	1.939	A

07:45 - 08:00

Arm	Total Demand (PCU/hr)	Circulating flow (PCU/hr)	Capacity (PCU/hr)	RFC	Throughput (PCU/hr)	End queue (PCU)	Delay (s)	Unsignalised level of service
1	380	179	2676	0.142	381	0.3	2.806	A
2	631	324	2946	0.214	632	0.3	1.896	A
3	0	955	1254	0.000	0	0.0	0.000	A
4	609	426	2337	0.260	609	0.5	2.885	A
5	5	1030	2104	0.003	5	0.0	1.714	A

08:00 - 08:15

Arm	Total Demand (PCU/hr)	Circulating flow (PCU/hr)	Capacity (PCU/hr)	RFC	Throughput (PCU/hr)	End queue (PCU)	Delay (s)	Unsignalised level of service
1	318	150	2708	0.118	319	0.2	2.695	A
2	529	271	3011	0.176	529	0.3	1.770	A
3	0	800	1372	0.000	0	0.0	0.000	A
4	510	356	2409	0.212	510	0.4	2.625	A
5	5	863	2280	0.002	5	0.0	1.581	A

2025 Base + Committed + Proposed, PM

Data Errors and Warnings

No errors or warnings

Junction Network

Junctions

Junction	Name	Junction type	Use circulating lanes	Arm order	Junction Delay (s)	Junction LOS
1	A1060 A1733 Humber Road	Standard Roundabout		1, 2, 3, 4, 5	3.04	A

Junction Network

Driving side	Lighting	Network delay (s)	Network LOS
Left	Normal/unknown	3.04	A

Traffic Demand

Demand Set Details

ID	Scenario name	Time Period name	Traffic profile type	Start time (HH:mm)	Finish time (HH:mm)	Time segment length (min)
D6	2025 Base + Committed + Proposed	PM	ONE HOUR	15:45	17:15	15

Vehicle mix source	PCU Factor for a HV (PCU)
HV Percentages	2.00

Demand overview (Traffic)

Arm	Linked arm	Use O-D data	Average Demand (PCU/hr)	Scaling Factor (%)
1		✓	984	100.000
2		✓	354	100.000
3		✓	10	100.000
4		✓	575	100.000
5		✓	3	100.000

Origin-Destination Data

Demand (PCU/hr)

		To				
		1	2	3	4	5
From	1	51	364	0	569	0
	2	127	0	0	226	1
	3	0	4	0	6	0
	4	316	253	2	0	4
	5	0	2	0	1	0

Vehicle Mix

Heavy Vehicle Percentages

		To				
From		1	2	3	4	5
	1	37	21	0	61	0
	2	37	9	100	20	0
	3	0	50	0	67	0
	4	91	20	75	40	100
	5	0	0	0	100	0

Detailed Demand Data

Demand for each time segment

Time Segment	Arm	Demand (PCU/hr)	Demand in PCU (PCU/hr)
15:45-16:00	1	741	741
	2	267	267
	3	8	8
	4	433	433
	5	0	0
16:00-16:15	1	885	885
	2	318	318
	3	9	9
	4	517	517
	5	0	0
16:15-16:30	1	1083	1083
	2	390	390
	3	11	11
	4	633	633
	5	0	0
16:30-16:45	1	1083	1083
	2	390	390
	3	11	11
	4	633	633
	5	0	0
16:45-17:00	1	885	885
	2	318	318
	3	9	9
	4	517	517
	5	0	0
17:00-17:15	1	741	741
	2	267	267
	3	8	8
	4	433	433
	5	0	0

Results

Results Summary for whole modelled period

Arm	Max RFC	Max Delay (s)	Max Queue (PCU)	Max LOS
1	0.42	3.47	1.0	A
2	0.16	2.14	0.2	A
3	0.01	4.98	0.0	A
4	0.25	2.82	0.5	A
5	0.00	0.00	0.0	A

Main Results for each time segment

15:45 - 16:00

Arm	Total Demand (PCU/hr)	Circulating flow (PCU/hr)	Capacity (PCU/hr)	RFC	Throughput (PCU/hr)	End queue (PCU)	Delay (s)	Unsignalised level of service
1	741	194	2659	0.279	739	0.5	2.666	A
2	267	467	2769	0.096	266	0.1	1.804	A
3	8	731	1424	0.005	7	0.0	4.058	A
4	433	137	2635	0.164	432	0.3	2.475	A
5	0	565	2592	0.000	0	0.0	0.000	A

16:00 - 16:15

Arm	Total Demand (PCU/hr)	Circulating flow (PCU/hr)	Capacity (PCU/hr)	RFC	Throughput (PCU/hr)	End queue (PCU)	Delay (s)	Unsignalised level of service
1	885	233	2617	0.338	884	0.7	2.954	A
2	318	559	2655	0.120	318	0.2	1.933	A
3	9	875	1315	0.007	9	0.0	4.402	A
4	517	164	2607	0.198	517	0.4	2.609	A
5	0	677	2476	0.000	0	0.0	0.000	A

16:15 - 16:30

Arm	Total Demand (PCU/hr)	Circulating flow (PCU/hr)	Capacity (PCU/hr)	RFC	Throughput (PCU/hr)	End queue (PCU)	Delay (s)	Unsignalised level of service
1	1083	285	2560	0.423	1082	1.0	3.463	A
2	390	684	2500	0.156	390	0.2	2.140	A
3	11	1071	1166	0.009	11	0.0	4.980	A
4	633	201	2569	0.246	633	0.5	2.817	A
5	0	828	2316	0.000	0	0.0	0.000	A

16:30 - 16:45

Arm	Total Demand (PCU/hr)	Circulating flow (PCU/hr)	Capacity (PCU/hr)	RFC	Throughput (PCU/hr)	End queue (PCU)	Delay (s)	Unsignalised level of service
1	1083	285	2559	0.423	1083	1.0	3.469	A
2	390	685	2499	0.156	390	0.2	2.141	A
3	11	1072	1165	0.009	11	0.0	4.983	A
4	633	201	2569	0.246	633	0.5	2.817	A
5	0	829	2315	0.000	0	0.0	0.000	A

16:45 - 17:00

Arm	Total Demand (PCU/hr)	Circulating flow (PCU/hr)	Capacity (PCU/hr)	RFC	Throughput (PCU/hr)	End queue (PCU)	Delay (s)	Unsignalised level of service
1	885	233	2617	0.338	886	0.7	2.963	A
2	318	560	2654	0.120	318	0.2	1.936	A
3	9	877	1314	0.007	9	0.0	4.407	A
4	517	165	2607	0.198	517	0.4	2.613	A
5	0	678	2475	0.000	0	0.0	0.000	A

17:00 - 17:15

Arm	Total Demand (PCU/hr)	Circulating flow (PCU/hr)	Capacity (PCU/hr)	RFC	Throughput (PCU/hr)	End queue (PCU)	Delay (s)	Unsignalised level of service
1	741	195	2658	0.279	742	0.6	2.675	A
2	267	469	2767	0.096	267	0.1	1.809	A
3	8	734	1423	0.005	8	0.0	4.064	A
4	433	138	2635	0.164	433	0.3	2.480	A
5	0	567	2590	0.000	0	0.0	0.000	A

Junctions 10
ARCADY 10 - Roundabout Module
Version: 10.0.4.1693 © Copyright TRL Software Limited, 2021
For sales and distribution information, program advice and maintenance, contact TRL Software: +44 (0)1344 379777 software@trl.co.uk trlsoftware.com
The users of this computer program for the solution of an engineering problem are in no way relieved of their responsibility for the correctness of the solution

Filename: J6 M180_A15 Calibrate.j10

Path: \\na.aecomnet.com\lfs\EMEA\Leeds-UKLDS2\Legacy\UKLDS2PFPSW001\WIP\LE_Projects\Newproje\60668866 - Humber Zero\400_Technical\Traffic & Transport\NH Comments 10.01.24\Junction Modelling\Modelling May 2024

Report generation date: 08/05/2024 13:53:30

- »Base 2025, AM
- »Base 2025, PM
- »Base 2025 + Committed, AM
- »Base 2025 + Committed, PM
- »Base 2025 + Committed + Proposed, AM
- »Base 2025 + Committed + Proposed, PM

Summary of junction performance

	AM					PM				
	Set ID	Queue (PCU)	Delay (s)	RFC	LOS	Set ID	Queue (PCU)	Delay (s)	RFC	LOS
Base 2025										
Arm 1	D1	7.2	23.29	0.87	C	D2	14.4	42.72	0.95	E
Arm 2		8.0	32.43	0.89	D		12.0	50.34	0.94	F
Arm 3		1.8	12.56	0.61	B		14.2	77.11	0.98	F
Arm 4		4.1	10.33	0.79	B		2.1	6.33	0.67	A
Base 2025 + Committed										
Arm 1	D3	6.8	22.06	0.87	C	D4	118.6	242.49	1.16	F
Arm 2		37.4	112.73	1.04	F		24.0	92.69	1.01	F
Arm 3		3.1	22.66	0.74	C		25.0	130.62	1.05	F
Arm 4		20.9	47.42	0.98	E		2.3	6.76	0.69	A
Base 2025 + Committed + Proposed										
Arm 1	D5	6.6	21.37	0.86	C	D6	142.7	300.61	1.20	F
Arm 2		45.2	130.61	1.06	F		22.9	89.34	1.00	F
Arm 3		3.4	24.40	0.76	C		24.4	127.96	1.04	F
Arm 4		29.6	63.45	1.00	F		2.3	6.80	0.69	A

There are warnings associated with one or more model runs - see the 'Data Errors and Warnings' tables for each Analysis or Demand Set.

Values shown are the highest values encountered over all time segments. Delay is the maximum value of average delay per arriving vehicle.

File summary

File Description

Title	
Location	
Site number	
Date	04/03/2024
Version	
Status	(new file)
Identifier	
Client	
Jobnumber	
Enumerator	NA\SimmonsA1
Description	

Units

Distance units	Speed units	Traffic units input	Traffic units results	Flow units	Average delay units	Total delay units	Rate of delay units
m	kph	PCU	PCU	perHour	s	-Min	perMin

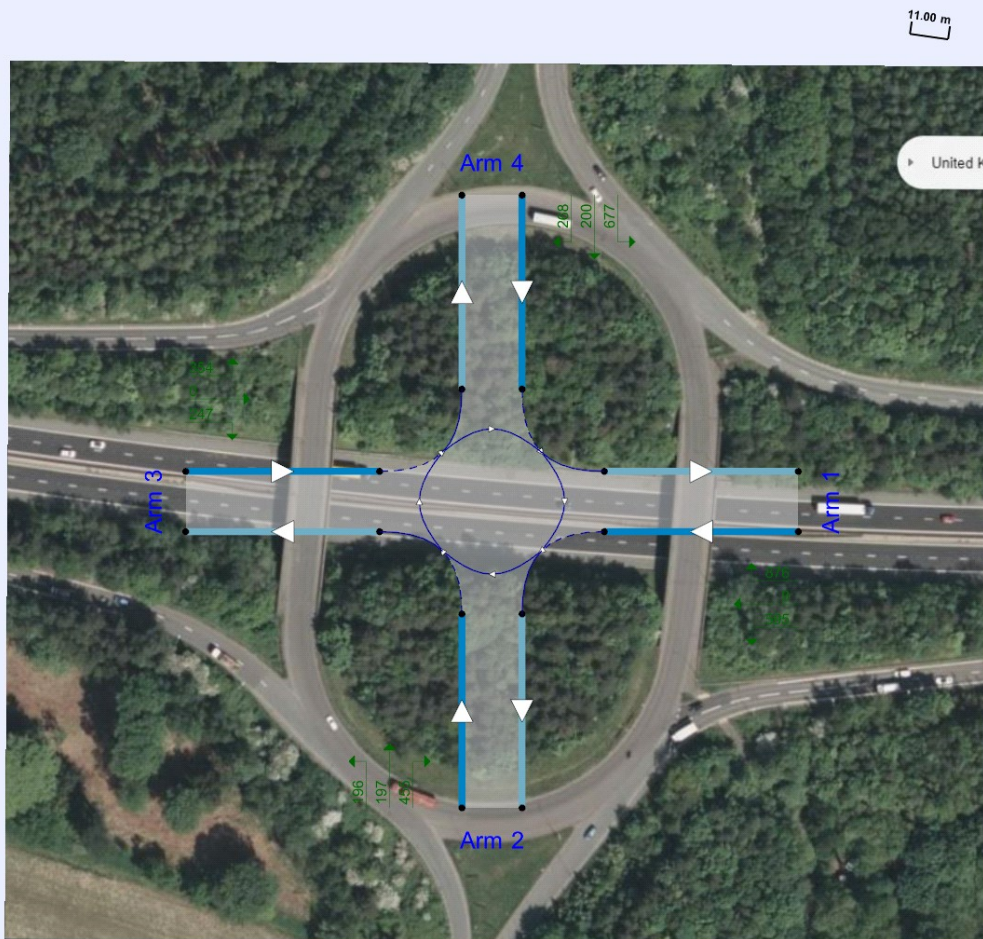

Flows show original traffic demand (PCU/hr).

The junction diagram reflects the last run of Junctions.

Analysis Options

Vehicle length (m)	Calculate Queue Percentiles	Calculate detailed queueing delay	Show lane queues in feet / metres	Show all PICADY stream intercepts	Calculate residual capacity	RFC Threshold	Average Delay threshold (s)	Queue threshold (PCU)	Use iterations with HCM roundabouts	Max number of iterations for roundabouts
5.75						0.85	36.00	20.00		500

Demand Set Summary

ID	Scenario name	Time Period name	Traffic profile type	Start time (HH:mm)	Finish time (HH:mm)	Time segment length (min)	Run automatically
D1	Base 2025	AM	ONE HOUR	06:45	08:15	15	✓
D2	Base 2025	PM	ONE HOUR	15:45	17:15	15	✓
D3	Base 2025 + Committed	AM	ONE HOUR	06:45	08:15	15	✓
D4	Base 2025 + Committed	PM	ONE HOUR	15:45	17:15	15	✓
D5	Base 2025 + Committed + Proposed	AM	ONE HOUR	06:45	08:15	15	✓
D6	Base 2025 + Committed + Proposed	PM	ONE HOUR	15:45	17:15	15	✓

Analysis Set Details

ID	Include in report	Network flow scaling factor (%)	Network capacity scaling factor (%)
A1	✓	100.000	100.000

Base 2025, AM

Data Errors and Warnings

Severity	Area	Item	Description
Warning	Large Roundabout	Arm 1 - Large roundabout data	Large Roundabout Circulating Flow is zero for one or more arms.

Junction Network

Junctions

Junction	Name	Junction type	Use circulating lanes	Arm order	Junction Delay (s)	Junction LOS
1	untitled	Large Roundabout		1, 2, 3, 4	19.42	C

Junction Network

Driving side	Lighting	Network delay (s)	Network LOS
Left	Normal/unknown	19.42	C

Arms

Arms

Arm	Name	Description	No give-way line
1	M180 East		
2	A15 South		
3	M180 West		
4	A15 North		

Roundabout Geometry

Arm	V - Approach road half-width (m)	E - Entry width (m)	I' - Effective flare length (m)	R - Entry radius (m)	D - Inscribed circle diameter (m)	PHI - Conflict (entry) angle (deg)	Entry only	Exit only
1	6.18	8.37	7.1	53.7	114.4	14.6		
2	5.28	7.82	3.2	59.4	111.3	18.2		
3	6.01	7.83	8.9	43.5	116.9	17.2		
4	7.85	8.30	4.1	125.1	120.7	16.3		

Large Roundabout Data

Arm	Circulating flow (PCU/hr)	Has entry-to-exit separation	Entry-to-exit separation (m)
1	0	✓	122.87
2	0	✓	53.30
3	0	✓	117.42
4	0	✓	61.45

Slope / Intercept / Capacity

Arm Intercept Adjustments

Arm	Type	Reason	Direct intercept adjustment (PCU/hr)
1	Direct		-700
2	Direct		-580
3	Direct		-523
4	Direct		-650

Roundabout Slope and Intercept used in model

Arm	Final slope	Final intercept (PCU/hr)
1	1.200	2298
2	1.064	2126
3	1.168	2401
4	1.291	2788

The slope and intercept shown above include any corrections and adjustments.

Traffic Demand

Demand Set Details

ID	Scenario name	Time Period name	Traffic profile type	Start time (HH:mm)	Finish time (HH:mm)	Time segment length (min)	Run automatically
D1	Base 2025	AM	ONE HOUR	06:45	08:15	15	✓

Vehicle mix varies over turn	Vehicle mix varies over entry	Vehicle mix source	PCU Factor for a HV (PCU)
✓	✓	HV Percentages	2.00

Demand overview (Traffic)

Arm	Linked arm	Profile type	Use O-D data	Average Demand (PCU/hr)	Scaling Factor (%)
1		ONE HOUR	✓	1069	100.000
2		ONE HOUR	✓	862	100.000
3		ONE HOUR	✓	472	100.000
4		ONE HOUR	✓	1332	100.000

Origin-Destination Data

Demand (PCU/hr)

		To			
		1	2	3	4
From	1	1	476	0	592
	2	446	0	247	169
	3	0	212	1	259
	4	826	197	305	4

Proportions

		To			
		1	2	3	4
From	1	0.00	0.45	0.00	0.55
	2	0.52	0.00	0.29	0.20
	3	0.00	0.45	0.00	0.55
	4	0.62	0.15	0.23	0.00

Vehicle Mix

Heavy Vehicle Percentages

		To			
		1	2	3	4
From	1	0	29	0	8
	2	21	0	18	15
	3	0	15	0	15
	4	10	13	15	0

Average PCU Per Veh

		To			
		1	2	3	4
From	1	1.000	1.290	1.000	1.080
	2	1.210	1.000	1.180	1.150
	3	1.000	1.150	1.000	1.150
	4	1.100	1.130	1.150	1.000

Detailed Demand Data

Demand for each time segment

Time Segment	Arm	Demand (PCU/hr)	Demand in PCU (PCU/hr)
06:45-07:00	1	805	805
	2	649	649
	3	355	355
	4	1003	1003
07:00-07:15	1	961	961
	2	775	775
	3	424	424
	4	1197	1197
07:15-07:30	1	1177	1177
	2	949	949
	3	520	520
	4	1467	1467
07:30-07:45	1	1177	1177
	2	949	949
	3	520	520
	4	1467	1467
07:45-08:00	1	961	961
	2	775	775
	3	424	424
	4	1197	1197
08:00-08:15	1	805	805
	2	649	649
	3	355	355
	4	1003	1003

Results

Results Summary for whole modelled period

Arm	Max RFC	Max Delay (s)	Max Queue (PCU)	Max LOS	Average Demand (PCU/hr)	Total Junction Arrivals (PCU)
1	0.87	23.29	7.2	C	981	1471
2	0.89	32.43	8.0	D	791	1186
3	0.61	12.56	1.8	B	433	650
4	0.79	10.33	4.1	B	1222	1833

Main Results for each time segment

06:45 - 07:00

Arm	Total Demand (PCU/hr)	Junction Arrivals (PCU)	Circulating flow (PCU/hr)	Capacity (PCU/hr)	RFC	Throughput (PCU/hr)	Throughput (exit side) (PCU/hr)	Start queue (PCU)	End queue (PCU)	Delay (s)	Unsignalised level of service
1	805	201	539	1651	0.487	800	954	0.0	1.1	4.901	A
2	649	162	676	1405	0.462	645	663	0.0	1.0	5.600	A
3	355	89	907	1341	0.265	354	414	0.0	0.4	4.183	A
4	1003	251	494	2150	0.466	999	767	0.0	1.0	3.476	A

07:00 - 07:15

Arm	Total Demand (PCU/hr)	Junction Arrivals (PCU)	Circulating flow (PCU/hr)	Capacity (PCU/hr)	RFC	Throughput (PCU/hr)	Throughput (exit side) (PCU/hr)	Start queue (PCU)	End queue (PCU)	Delay (s)	Unsignalised level of service
1	961	240	645	1524	0.630	958	1141	1.1	1.9	7.350	A
2	775	194	809	1264	0.613	772	793	1.0	1.8	8.635	A
3	424	106	1085	1133	0.374	423	496	0.4	0.7	5.820	A
4	1197	299	591	2025	0.591	1195	917	1.0	1.6	4.824	A

07:15 - 07:30

Arm	Total Demand (PCU/hr)	Junction Arrivals (PCU)	Circulating flow (PCU/hr)	Capacity (PCU/hr)	RFC	Throughput (PCU/hr)	Throughput (exit side) (PCU/hr)	Start queue (PCU)	End queue (PCU)	Delay (s)	Unsignalised level of service
1	1177	294	786	1355	0.869	1158	1385	1.9	6.6	19.735	C
2	949	237	982	1081	0.878	929	963	1.8	6.9	25.439	D
3	520	130	1310	871	0.596	516	601	0.7	1.6	11.513	B
4	1467	367	714	1865	0.786	1457	1111	1.6	3.9	9.626	A

07:30 - 07:45

Arm	Total Demand (PCU/hr)	Junction Arrivals (PCU)	Circulating flow (PCU/hr)	Capacity (PCU/hr)	RFC	Throughput (PCU/hr)	Throughput (exit side) (PCU/hr)	Start queue (PCU)	End queue (PCU)	Delay (s)	Unsignalised level of service
1	1177	294	791	1349	0.872	1174	1399	6.6	7.2	23.290	C
2	949	237	993	1069	0.888	945	973	6.9	8.0	32.432	D
3	520	130	1330	848	0.613	519	607	1.6	1.8	12.565	B
4	1467	367	724	1853	0.792	1466	1125	3.9	4.1	10.331	B

07:45 - 08:00

Arm	Total Demand (PCU/hr)	Junction Arrivals (PCU)	Circulating flow (PCU/hr)	Capacity (PCU/hr)	RFC	Throughput (PCU/hr)	Throughput (exit side) (PCU/hr)	Start queue (PCU)	End queue (PCU)	Delay (s)	Unsignalised level of service
1	961	240	652	1516	0.634	982	1163	7.2	2.1	8.131	A
2	775	194	825	1247	0.621	799	808	8.0	2.0	10.045	B
3	424	106	1118	1095	0.388	428	506	1.8	0.7	6.246	A
4	1197	299	608	2003	0.598	1207	939	4.1	1.7	5.103	A

08:00 - 08:15

Arm	Total Demand (PCU/hr)	Junction Arrivals (PCU)	Circulating flow (PCU/hr)	Capacity (PCU/hr)	RFC	Throughput (PCU/hr)	Throughput (exit side) (PCU/hr)	Start queue (PCU)	End queue (PCU)	Delay (s)	Unsignalised level of service
1	805	201	543	1647	0.489	809	962	2.1	1.1	5.021	A
2	649	162	683	1399	0.464	653	669	2.0	1.0	5.765	A
3	355	89	917	1330	0.267	357	418	0.7	0.4	4.258	A
4	1003	251	499	2143	0.468	1006	774	1.7	1.0	3.537	A

Base 2025, PM

Data Errors and Warnings

Severity	Area	Item	Description
Warning	Large Roundabout	Arm 1 - Large roundabout data	Large Roundabout Circulating Flow is zero for one or more arms.

Junction Network

Junctions

Junction	Name	Junction type	Use circulating lanes	Arm order	Junction Delay (s)	Junction LOS
1	untitled	Large Roundabout		1, 2, 3, 4	38.99	E

Junction Network

Driving side	Lighting	Network delay (s)	Network LOS
Left	Normal/unknown	38.99	E

Arms

Arms

[same as above]

Roundabout Geometry

[same as above]

Large Roundabout Data

Arm	Circulating flow (PCU/hr)	Has entry-to-exit separation	Entry-to-exit separation (m)
1	0	✓	122.87
2	0	✓	53.30
3	0	✓	117.42
4	0	✓	61.45

Slope / Intercept / Capacity

[same as above]

Traffic Demand

Demand Set Details

ID	Scenario name	Time Period name	Traffic profile type	Start time (HH:mm)	Finish time (HH:mm)	Time segment length (min)	Run automatically
D2	Base 2025	PM	ONE HOUR	15:45	17:15	15	✓

Vehicle mix varies over turn	Vehicle mix varies over entry	Vehicle mix source	PCU Factor for a HV (PCU)
✓	✓	HV Percentages	2.00

Demand overview (Traffic)

Arm	Linked arm	Profile type	Use O-D data	Average Demand (PCU/hr)	Scaling Factor (%)
1		ONE HOUR	✓	1174	100.000
2		ONE HOUR	✓	827	100.000
3		ONE HOUR	✓	603	100.000
4		ONE HOUR	✓	1125	100.000

Origin-Destination Data

Demand (PCU/hr)

	To				
	1	2	3	4	
From	1	0	451	0	723
	2	434	0	196	197
	3	0	247	2	354
	4	656	200	268	1

Proportions

	To				
	1	2	3	4	
From	1	0.00	0.38	0.00	0.62
	2	0.52	0.00	0.24	0.24
	3	0.00	0.41	0.00	0.59
	4	0.58	0.18	0.24	0.00

Vehicle Mix

Heavy Vehicle Percentages

	To				
	1	2	3	4	
From	1	0	20	0	8
	2	22	0	8	13
	3	0	14	0	11
	4	5	9	3	0

Average PCU Per Veh

	To				
	1	2	3	4	
From	1	1.000	1.200	1.000	1.080
	2	1.220	1.000	1.080	1.130
	3	1.000	1.140	1.000	1.110
	4	1.050	1.090	1.030	1.000

Detailed Demand Data

Demand for each time segment

Time Segment	Arm	Demand (PCU/hr)	Demand in PCU (PCU/hr)
15:45-16:00	1	884	884
	2	623	623
	3	454	454
	4	847	847
16:00-16:15	1	1055	1055
	2	743	743
	3	542	542
	4	1011	1011
16:15-16:30	1	1293	1293
	2	911	911
	3	664	664
	4	1239	1239
16:30-16:45	1	1293	1293
	2	911	911
	3	664	664
	4	1239	1239
16:45-17:00	1	1055	1055
	2	743	743
	3	542	542
	4	1011	1011
17:00-17:15	1	884	884
	2	623	623
	3	454	454
	4	847	847

Results

Results Summary for whole modelled period

Arm	Max RFC	Max Delay (s)	Max Queue (PCU)	Max LOS	Average Demand (PCU/hr)	Total Junction Arrivals (PCU)
1	0.95	42.72	14.4	E	1077	1616
2	0.94	50.34	12.0	F	759	1138
3	0.98	77.11	14.2	F	553	830
4	0.67	6.33	2.1	A	1032	1548

Main Results for each time segment

15:45 - 16:00

Arm	Total Demand (PCU/hr)	Junction Arrivals (PCU)	Circulating flow (PCU/hr)	Capacity (PCU/hr)	RFC	Throughput (PCU/hr)	Throughput (exit side) (PCU/hr)	Start queue (PCU)	End queue (PCU)	Delay (s)	Unsignalised level of service
1	884	221	538	1652	0.535	879	817	0.0	1.3	5.192	A
2	623	156	745	1333	0.467	619	673	0.0	1.0	5.824	A
3	454	113	1014	1217	0.373	451	349	0.0	0.7	5.258	A
4	847	212	511	2128	0.398	844	954	0.0	0.7	2.943	A

16:00 - 16:15

Arm	Total Demand (PCU/hr)	Junction Arrivals (PCU)	Circulating flow (PCU/hr)	Capacity (PCU/hr)	RFC	Throughput (PCU/hr)	Throughput (exit side) (PCU/hr)	Start queue (PCU)	End queue (PCU)	Delay (s)	Unsignalised level of service
1	1055	264	644	1526	0.692	1051	977	1.3	2.4	8.424	A
2	743	186	890	1178	0.631	740	804	1.0	1.9	9.469	A
3	542	136	1212	985	0.550	539	418	0.7	1.3	9.006	A
4	1011	253	611	1999	0.506	1010	1141	0.7	1.1	3.824	A

16:15 - 16:30

Arm	Total Demand (PCU/hr)	Junction Arrivals (PCU)	Circulating flow (PCU/hr)	Capacity (PCU/hr)	RFC	Throughput (PCU/hr)	Throughput (exit side) (PCU/hr)	Start queue (PCU)	End queue (PCU)	Delay (s)	Unsignalised level of service
1	1293	323	777	1366	0.946	1255	1183	2.4	11.7	29.789	D
2	911	228	1070	986	0.923	882	962	1.9	9.1	33.625	D
3	664	166	1447	711	0.934	635	505	1.3	8.7	42.618	E
4	1239	310	725	1852	0.669	1235	1357	1.1	2.1	6.093	A

16:30 - 16:45

Arm	Total Demand (PCU/hr)	Junction Arrivals (PCU)	Circulating flow (PCU/hr)	Capacity (PCU/hr)	RFC	Throughput (PCU/hr)	Throughput (exit side) (PCU/hr)	Start queue (PCU)	End queue (PCU)	Delay (s)	Unsignalised level of service
1	1293	323	781	1361	0.950	1282	1194	11.7	14.4	42.717	E
2	911	228	1088	968	0.941	899	976	9.1	12.0	50.339	F
3	664	166	1476	677	0.981	642	510	8.7	14.2	77.113	F
4	1239	310	737	1836	0.675	1238	1382	2.1	2.1	6.328	A

16:45 - 17:00

Arm	Total Demand (PCU/hr)	Junction Arrivals (PCU)	Circulating flow (PCU/hr)	Capacity (PCU/hr)	RFC	Throughput (PCU/hr)	Throughput (exit side) (PCU/hr)	Start queue (PCU)	End queue (PCU)	Delay (s)	Unsignalised level of service
1	1055	264	668	1497	0.705	1102	1003	14.4	2.8	11.383	B
2	743	186	923	1143	0.651	782	846	12.0	2.2	12.819	B
3	542	136	1277	910	0.596	592	429	14.2	1.7	14.674	B
4	1011	253	655	1942	0.521	1015	1214	2.1	1.2	4.103	A

17:00 - 17:15

Arm	Total Demand (PCU/hr)	Junction Arrivals (PCU)	Circulating flow (PCU/hr)	Capacity (PCU/hr)	RFC	Throughput (PCU/hr)	Throughput (exit side) (PCU/hr)	Start queue (PCU)	End queue (PCU)	Delay (s)	Unsignalised level of service
1	884	221	543	1647	0.537	890	824	2.8	1.3	5.382	A
2	623	156	752	1325	0.470	627	680	2.2	1.0	6.040	A
3	454	113	1027	1201	0.378	458	352	1.7	0.7	5.465	A
4	847	212	518	2118	0.400	849	967	1.2	0.7	2.986	A

Base 2025 + Committed, AM

Data Errors and Warnings

Severity	Area	Item	Description
Warning	Large Roundabout	Arm 1 - Large roundabout data	Large Roundabout Circulating Flow is zero for one or more arms.

Junction Network

Junctions

Junction	Name	Junction type	Use circulating lanes	Arm order	Junction Delay (s)	Junction LOS
1	untitled	Large Roundabout		1, 2, 3, 4	54.25	F

Junction Network

Driving side	Lighting	Network delay (s)	Network LOS
Left	Normal/unknown	54.25	F

Arms

Arms

[same as above]

Roundabout Geometry

[same as above]

Large Roundabout Data

Arm	Circulating flow (PCU/hr)	Has entry-to-exit separation	Entry-to-exit separation (m)
1	0	✓	122.87
2	0	✓	53.30
3	0	✓	117.42
4	0	✓	61.45

Slope / Intercept / Capacity

[same as above]

Traffic Demand

Demand Set Details

ID	Scenario name	Time Period name	Traffic profile type	Start time (HH:mm)	Finish time (HH:mm)	Time segment length (min)	Run automatically
D3	Base 2025 + Committed	AM	ONE HOUR	06:45	08:15	15	✓

Vehicle mix varies over turn	Vehicle mix varies over entry	Vehicle mix source	PCU Factor for a HV (PCU)
✓	✓	HV Percentages	2.00

Demand overview (Traffic)

Arm	Linked arm	Profile type	Use O-D data	Average Demand (PCU/hr)	Scaling Factor (%)
1		ONE HOUR	✓	1069	100.000
2		ONE HOUR	✓	1017	100.000
3		ONE HOUR	✓	472	100.000
4		ONE HOUR	✓	1487	100.000

Origin-Destination Data

Demand (PCU/hr)

		To			
		1	2	3	4
From	1	1	476	0	592
	2	601	0	247	169
	3	0	212	1	259
	4	981	197	305	4

Proportions

		To			
		1	2	3	4
From	1	0.00	0.45	0.00	0.55
	2	0.59	0.00	0.24	0.17
	3	0.00	0.45	0.00	0.55
	4	0.66	0.13	0.21	0.00

Vehicle Mix

Heavy Vehicle Percentages

		To			
		1	2	3	4
From	1	0	29	0	8
	2	21	0	18	15
	3	0	15	0	15
	4	10	13	15	0

Average PCU Per Veh

		To			
		1	2	3	4
From	1	1.000	1.290	1.000	1.080
	2	1.210	1.000	1.180	1.150
	3	1.000	1.150	1.000	1.150
	4	1.100	1.130	1.150	1.000

Detailed Demand Data

Demand for each time segment

Time Segment	Arm	Demand (PCU/hr)	Demand in PCU (PCU/hr)
06:45-07:00	1	805	805
	2	766	766
	3	355	355
	4	1119	1119
07:00-07:15	1	961	961
	2	914	914
	3	424	424
	4	1337	1337
07:15-07:30	1	1177	1177
	2	1120	1120
	3	520	520
	4	1637	1637
07:30-07:45	1	1177	1177
	2	1120	1120
	3	520	520
	4	1637	1637
07:45-08:00	1	961	961
	2	914	914
	3	424	424
	4	1337	1337
08:00-08:15	1	805	805
	2	766	766
	3	355	355
	4	1119	1119

Results

Results Summary for whole modelled period

Arm	Max RFC	Max Delay (s)	Max Queue (PCU)	Max LOS	Average Demand (PCU/hr)	Total Junction Arrivals (PCU)
1	0.87	22.06	6.8	C	981	1471
2	1.04	112.73	37.4	F	933	1400
3	0.74	22.66	3.1	C	433	650
4	0.98	47.42	20.9	E	1364	2047

Main Results for each time segment

06:45 - 07:00

Arm	Total Demand (PCU/hr)	Junction Arrivals (PCU)	Circulating flow (PCU/hr)	Capacity (PCU/hr)	RFC	Throughput (PCU/hr)	Throughput (exit side) (PCU/hr)	Start queue (PCU)	End queue (PCU)	Delay (s)	Unsignalised level of service
1	805	201	539	1652	0.487	800	1185	0.0	1.1	4.898	A
2	766	191	676	1406	0.545	760	663	0.0	1.4	6.592	A
3	355	89	1022	1207	0.294	353	414	0.0	0.5	4.839	A
4	1119	280	609	2001	0.559	1114	767	0.0	1.4	4.492	A

07:00 - 07:15

Arm	Total Demand (PCU/hr)	Junction Arrivals (PCU)	Circulating flow (PCU/hr)	Capacity (PCU/hr)	RFC	Throughput (PCU/hr)	Throughput (exit side) (PCU/hr)	Start queue (PCU)	End queue (PCU)	Delay (s)	Unsignalised level of service
1	961	240	644	1526	0.630	958	1416	1.1	1.9	7.331	A
2	914	229	809	1265	0.723	908	793	1.4	3.0	11.828	B
3	424	106	1222	973	0.436	423	494	0.5	0.9	7.494	A
4	1337	334	728	1848	0.724	1331	917	1.4	2.8	7.665	A

07:15 - 07:30

Arm	Total Demand (PCU/hr)	Junction Arrivals (PCU)	Circulating flow (PCU/hr)	Capacity (PCU/hr)	RFC	Throughput (PCU/hr)	Throughput (exit side) (PCU/hr)	Start queue (PCU)	End queue (PCU)	Delay (s)	Unsignalised level of service
1	1177	294	771	1373	0.857	1160	1664	1.9	6.1	18.441	C
2	1120	280	975	1088	1.029	1042	957	3.0	22.4	57.687	F
3	520	130	1437	723	0.719	512	580	0.9	2.7	19.023	C
4	1637	409	848	1693	0.967	1587	1101	2.8	15.3	29.600	D

07:30 - 07:45

Arm	Total Demand (PCU/hr)	Junction Arrivals (PCU)	Circulating flow (PCU/hr)	Capacity (PCU/hr)	RFC	Throughput (PCU/hr)	Throughput (exit side) (PCU/hr)	Start queue (PCU)	End queue (PCU)	Delay (s)	Unsignalised level of service
1	1177	294	783	1359	0.866	1174	1693	6.1	6.8	22.065	C
2	1120	280	988	1074	1.043	1060	969	22.4	37.4	112.726	F
3	520	130	1458	698	0.744	518	590	2.7	3.1	22.657	C
4	1637	409	861	1676	0.977	1615	1115	15.3	20.9	47.418	E

07:45 - 08:00

Arm	Total Demand (PCU/hr)	Junction Arrivals (PCU)	Circulating flow (PCU/hr)	Capacity (PCU/hr)	RFC	Throughput (PCU/hr)	Throughput (exit side) (PCU/hr)	Start queue (PCU)	End queue (PCU)	Delay (s)	Unsignalised level of service
1	961	240	673	1491	0.645	980	1548	6.8	2.2	8.482	A
2	914	229	836	1235	0.740	1049	816	37.4	3.7	37.365	E
3	424	106	1342	834	0.509	432	544	3.1	1.2	10.477	B
4	1337	334	816	1734	0.771	1405	958	20.9	3.9	14.457	B

08:00 - 08:15

Arm	Total Demand (PCU/hr)	Junction Arrivals (PCU)	Circulating flow (PCU/hr)	Capacity (PCU/hr)	RFC	Throughput (PCU/hr)	Throughput (exit side) (PCU/hr)	Start queue (PCU)	End queue (PCU)	Delay (s)	Unsignalised level of service
1	805	201	546	1643	0.490	809	1204	2.2	1.1	5.048	A
2	766	191	684	1397	0.548	775	671	3.7	1.5	6.986	A
3	355	89	1038	1188	0.299	358	421	1.2	0.5	5.004	A
4	1119	280	620	1987	0.563	1129	776	3.9	1.5	4.728	A

Base 2025 + Committed, PM

Data Errors and Warnings

Severity	Area	Item	Description
Warning	Large Roundabout	Arm 1 - Large roundabout data	Large Roundabout Circulating Flow is zero for one or more arms.

Junction Network

Junctions

Junction	Name	Junction type	Use circulating lanes	Arm order	Junction Delay (s)	Junction LOS
1	untitled	Large Roundabout		1, 2, 3, 4	127.57	F

Junction Network

Driving side	Lighting	Network delay (s)	Network LOS
Left	Normal/unknown	127.57	F

Arms

Arms

[same as above]

Roundabout Geometry

[same as above]

Large Roundabout Data

Arm	Circulating flow (PCU/hr)	Has entry-to-exit separation	Entry-to-exit separation (m)
1	0	✓	122.87
2	0	✓	53.30
3	0	✓	117.42
4	0	✓	61.45

Slope / Intercept / Capacity

[same as above]

Traffic Demand

Demand Set Details

ID	Scenario name	Time Period name	Traffic profile type	Start time (HH:mm)	Finish time (HH:mm)	Time segment length (min)	Run automatically
D4	Base 2025 + Committed	PM	ONE HOUR	15:45	17:15	15	✓

Vehicle mix varies over turn	Vehicle mix varies over entry	Vehicle mix source	PCU Factor for a HV (PCU)
✓	✓	HV Percentages	2.00

Demand overview (Traffic)

Arm	Linked arm	Profile type	Use O-D data	Average Demand (PCU/hr)	Scaling Factor (%)
1		ONE HOUR	✓	1446	100.000
2		ONE HOUR	✓	848	100.000
3		ONE HOUR	✓	603	100.000
4		ONE HOUR	✓	1146	100.000

Origin-Destination Data

Demand (PCU/hr)

	To				
	1	2	3	4	
From	1	9	573	9	855
	2	455	0	196	197
	3	0	247	2	354
	4	677	200	268	1

Proportions

	To				
	1	2	3	4	
From	1	0.01	0.40	0.01	0.59
	2	0.54	0.00	0.23	0.23
	3	0.00	0.41	0.00	0.59
	4	0.59	0.17	0.23	0.00

Vehicle Mix

Heavy Vehicle Percentages

	To				
	1	2	3	4	
From	1	0	20	0	8
	2	22	0	8	13
	3	0	14	0	11
	4	5	9	3	0

Average PCU Per Veh

	To				
	1	2	3	4	
From	1	1.000	1.200	1.000	1.080
	2	1.220	1.000	1.080	1.130
	3	1.000	1.140	1.000	1.110
	4	1.050	1.090	1.030	1.000

Detailed Demand Data

Demand for each time segment

Time Segment	Arm	Demand (PCU/hr)	Demand in PCU (PCU/hr)
15:45-16:00	1	1089	1089
	2	638	638
	3	454	454
	4	863	863
16:00-16:15	1	1300	1300
	2	762	762
	3	542	542
	4	1030	1030
16:15-16:30	1	1592	1592
	2	934	934
	3	664	664
	4	1262	1262
16:30-16:45	1	1592	1592
	2	934	934
	3	664	664
	4	1262	1262
16:45-17:00	1	1300	1300
	2	762	762
	3	542	542
	4	1030	1030
17:00-17:15	1	1089	1089
	2	638	638
	3	454	454
	4	863	863

Results

Results Summary for whole modelled period

Arm	Max RFC	Max Delay (s)	Max Queue (PCU)	Max LOS	Average Demand (PCU/hr)	Total Junction Arrivals (PCU)
1	1.16	242.49	118.6	F	1327	1990
2	1.01	92.69	24.0	F	778	1167
3	1.05	130.62	25.0	F	553	830
4	0.69	6.76	2.3	A	1052	1577

Main Results for each time segment

15:45 - 16:00

Arm	Total Demand (PCU/hr)	Junction Arrivals (PCU)	Circulating flow (PCU/hr)	Capacity (PCU/hr)	RFC	Throughput (PCU/hr)	Throughput (exit side) (PCU/hr)	Start queue (PCU)	End queue (PCU)	Delay (s)	Unsignalised level of service
1	1089	272	538	1653	0.659	1080	855	0.0	2.1	6.963	A
2	638	160	855	1215	0.525	633	763	0.0	1.3	7.142	A
3	454	113	1133	1078	0.421	451	356	0.0	0.8	6.411	A
4	863	216	533	2100	0.411	860	1051	0.0	0.7	3.048	A

16:00 - 16:15

Arm	Total Demand (PCU/hr)	Junction Arrivals (PCU)	Circulating flow (PCU/hr)	Capacity (PCU/hr)	RFC	Throughput (PCU/hr)	Throughput (exit side) (PCU/hr)	Start queue (PCU)	End queue (PCU)	Delay (s)	Unsignalised level of service
1	1300	325	643	1527	0.851	1285	1021	2.1	5.8	15.854	C
2	762	191	1019	1041	0.733	755	909	1.3	3.0	14.346	B
3	542	136	1350	825	0.657	537	425	0.8	2.1	13.809	B
4	1030	258	635	1968	0.524	1029	1252	0.7	1.1	4.024	A

16:15 - 16:30

Arm	Total Demand (PCU/hr)	Junction Arrivals (PCU)	Circulating flow (PCU/hr)	Capacity (PCU/hr)	RFC	Throughput (PCU/hr)	Throughput (exit side) (PCU/hr)	Start queue (PCU)	End queue (PCU)	Delay (s)	Unsignalised level of service
1	1592	398	769	1376	1.157	1362	1224	5.8	63.2	101.795	F
2	934	233	1120	934	1.000	881	1012	3.0	16.3	53.662	F
3	664	166	1492	658	1.008	616	508	2.1	14.0	64.328	F
4	1262	315	735	1838	0.686	1257	1373	1.1	2.3	6.469	A

16:30 - 16:45

Arm	Total Demand (PCU/hr)	Junction Arrivals (PCU)	Circulating flow (PCU/hr)	Capacity (PCU/hr)	RFC	Throughput (PCU/hr)	Throughput (exit side) (PCU/hr)	Start queue (PCU)	End queue (PCU)	Delay (s)	Unsignalised level of service
1	1592	398	772	1372	1.161	1370	1238	63.2	118.6	242.489	F
2	934	233	1126	927	1.007	903	1017	16.3	24.0	92.685	F
3	664	166	1514	633	1.049	620	514	14.0	25.0	130.621	F
4	1262	315	749	1821	0.693	1261	1385	2.3	2.3	6.761	A

16:45 - 17:00

Arm	Total Demand (PCU/hr)	Junction Arrivals (PCU)	Circulating flow (PCU/hr)	Capacity (PCU/hr)	RFC	Throughput (PCU/hr)	Throughput (exit side) (PCU/hr)	Start queue (PCU)	End queue (PCU)	Delay (s)	Unsignalised level of service
1	1300	325	670	1495	0.870	1481	1065	118.6	73.4	233.299	F
2	762	191	1139	913	0.835	830	1012	24.0	7.1	59.431	F
3	542	136	1524	622	0.872	597	445	25.0	11.4	117.616	F
4	1030	258	701	1883	0.547	1034	1419	2.3	1.3	4.486	A

17:00 - 17:15

Arm	Total Demand (PCU/hr)	Junction Arrivals (PCU)	Circulating flow (PCU/hr)	Capacity (PCU/hr)	RFC	Throughput (PCU/hr)	Throughput (exit side) (PCU/hr)	Start queue (PCU)	End queue (PCU)	Delay (s)	Unsignalised level of service
1	1089	272	558	1629	0.668	1373	873	73.4	2.4	42.115	E
2	638	160	1034	1025	0.623	659	897	7.1	2.0	12.037	B
3	454	113	1328	850	0.534	494	365	11.4	1.3	12.617	B
4	863	216	566	2057	0.420	865	1256	1.3	0.8	3.184	A

Base 2025 + Committed + Proposed, AM

Data Errors and Warnings

Severity	Area	Item	Description
Warning	Large Roundabout	Arm 1 - Large roundabout data	Large Roundabout Circulating Flow is zero for one or more arms.

Junction Network

Junctions

Junction	Name	Junction type	Use circulating lanes	Arm order	Junction Delay (s)	Junction LOS
1	untitled	Large Roundabout		1, 2, 3, 4	65.01	F

Junction Network

Driving side	Lighting	Network delay (s)	Network LOS
Left	Normal/unknown	65.01	F

Arms

Arms

[same as above]

Roundabout Geometry

[same as above]

Large Roundabout Data

Arm	Circulating flow (PCU/hr)	Has entry-to-exit separation	Entry-to-exit separation (m)
1	0	✓	122.87
2	0	✓	53.30
3	0	✓	117.42
4	0	✓	61.45

Slope / Intercept / Capacity

[same as above]

Traffic Demand

Demand Set Details

ID	Scenario name	Time Period name	Traffic profile type	Start time (HH:mm)	Finish time (HH:mm)	Time segment length (min)	Run automatically
D5	Base 2025 + Committed + Proposed	AM	ONE HOUR	06:45	08:15	15	✓

Vehicle mix varies over turn	Vehicle mix varies over entry	Vehicle mix source	PCU Factor for a HV (PCU)
✓	✓	HV Percentages	2.00

Demand overview (Traffic)

Arm	Linked arm	Profile type	Use O-D data	Average Demand (PCU/hr)	Scaling Factor (%)
1		ONE HOUR	✓	1069	100.000
2		ONE HOUR	✓	1039	100.000
3		ONE HOUR	✓	472	100.000
4		ONE HOUR	✓	1509	100.000

Origin-Destination Data

Demand (PCU/hr)

		To			
		1	2	3	4
From	1	1	476	0	592
	2	623	0	247	169
	3	0	212	1	259
	4	1003	197	305	4

Proportions

		To			
		1	2	3	4
From	1	0.00	0.45	0.00	0.55
	2	0.60	0.00	0.24	0.16
	3	0.00	0.45	0.00	0.55
	4	0.66	0.13	0.20	0.00

Vehicle Mix

Heavy Vehicle Percentages

		To			
		1	2	3	4
From	1	0	29	0	8
	2	21	0	18	15
	3	0	15	0	15
	4	10	13	15	0

Average PCU Per Veh

		To			
		1	2	3	4
From	1	1.000	1.290	1.000	1.080
	2	1.210	1.000	1.180	1.150
	3	1.000	1.150	1.000	1.150
	4	1.100	1.130	1.150	1.000

Detailed Demand Data

Demand for each time segment

Time Segment	Arm	Demand (PCU/hr)	Demand in PCU (PCU/hr)
06:45-07:00	1	805	805
	2	782	782
	3	355	355
	4	1136	1136
07:00-07:15	1	961	961
	2	934	934
	3	424	424
	4	1357	1357
07:15-07:30	1	1177	1177
	2	1144	1144
	3	520	520
	4	1661	1661
07:30-07:45	1	1177	1177
	2	1144	1144
	3	520	520
	4	1661	1661
07:45-08:00	1	961	961
	2	934	934
	3	424	424
	4	1357	1357
08:00-08:15	1	805	805
	2	782	782
	3	355	355
	4	1136	1136

Results

Results Summary for whole modelled period

Arm	Max RFC	Max Delay (s)	Max Queue (PCU)	Max LOS	Average Demand (PCU/hr)	Total Junction Arrivals (PCU)
1	0.86	21.37	6.6	C	981	1471
2	1.06	130.61	45.2	F	953	1430
3	0.76	24.40	3.4	C	433	650
4	1.00	63.45	29.6	F	1385	2077

Main Results for each time segment

06:45 - 07:00

Arm	Total Demand (PCU/hr)	Junction Arrivals (PCU)	Circulating flow (PCU/hr)	Capacity (PCU/hr)	RFC	Throughput (PCU/hr)	Throughput (exit side) (PCU/hr)	Start queue (PCU)	End queue (PCU)	Delay (s)	Unsignalised level of service
1	805	201	538	1652	0.487	800	1217	0.0	1.1	4.897	A
2	782	196	676	1406	0.556	776	663	0.0	1.5	6.760	A
3	355	89	1039	1188	0.299	353	414	0.0	0.5	4.950	A
4	1136	284	626	1980	0.574	1130	766	0.0	1.5	4.684	A

07:00 - 07:15

Arm	Total Demand (PCU/hr)	Junction Arrivals (PCU)	Circulating flow (PCU/hr)	Capacity (PCU/hr)	RFC	Throughput (PCU/hr)	Throughput (exit side) (PCU/hr)	Start queue (PCU)	End queue (PCU)	Delay (s)	Unsignalised level of service
1	961	240	643	1526	0.630	958	1454	1.1	1.9	7.326	A
2	934	234	809	1265	0.738	927	792	1.5	3.2	12.462	B
3	424	106	1242	951	0.446	423	494	0.5	0.9	7.808	A
4	1357	339	748	1823	0.744	1350	917	1.5	3.1	8.364	A

07:15 - 07:30

Arm	Total Demand (PCU/hr)	Junction Arrivals (PCU)	Circulating flow (PCU/hr)	Capacity (PCU/hr)	RFC	Throughput (PCU/hr)	Throughput (exit side) (PCU/hr)	Start queue (PCU)	End queue (PCU)	Delay (s)	Unsignalised level of service
1	1177	294	766	1380	0.853	1161	1692	1.9	5.9	17.978	C
2	1144	286	972	1091	1.048	1053	955	3.2	26.0	63.970	F
3	520	130	1451	707	0.735	512	574	0.9	2.9	20.415	C
4	1661	415	863	1673	0.993	1595	1099	3.1	19.8	35.931	E

07:30 - 07:45

Arm	Total Demand (PCU/hr)	Junction Arrivals (PCU)	Circulating flow (PCU/hr)	Capacity (PCU/hr)	RFC	Throughput (PCU/hr)	Throughput (exit side) (PCU/hr)	Start queue (PCU)	End queue (PCU)	Delay (s)	Unsignalised level of service
1	1177	294	778	1365	0.862	1174	1720	5.9	6.6	21.372	C
2	1144	286	985	1077	1.062	1067	967	26.0	45.2	130.609	F
3	520	130	1469	685	0.759	518	583	2.9	3.4	24.398	C
4	1661	415	875	1658	1.002	1622	1112	19.8	29.6	63.452	F

07:45 - 08:00

Arm	Total Demand (PCU/hr)	Junction Arrivals (PCU)	Circulating flow (PCU/hr)	Capacity (PCU/hr)	RFC	Throughput (PCU/hr)	Throughput (exit side) (PCU/hr)	Start queue (PCU)	End queue (PCU)	Delay (s)	Unsignalised level of service
1	961	240	683	1479	0.650	979	1626	6.6	2.2	8.660	A
2	934	234	842	1230	0.760	1098	820	45.2	4.2	55.730	F
3	424	106	1383	785	0.540	432	556	3.4	1.4	11.970	B
4	1357	339	854	1685	0.805	1455	962	29.6	5.0	23.491	C

08:00 - 08:15

Arm	Total Demand (PCU/hr)	Junction Arrivals (PCU)	Circulating flow (PCU/hr)	Capacity (PCU/hr)	RFC	Throughput (PCU/hr)	Throughput (exit side) (PCU/hr)	Start queue (PCU)	End queue (PCU)	Delay (s)	Unsignalised level of service
1	805	201	548	1641	0.490	809	1241	2.2	1.1	5.063	A
2	782	196	685	1396	0.560	793	672	4.2	1.5	7.237	A
3	355	89	1056	1167	0.304	359	422	1.4	0.5	5.143	A
4	1136	284	638	1964	0.579	1150	777	5.0	1.5	5.006	A

Base 2025 + Committed + Proposed, PM

Data Errors and Warnings

Severity	Area	Item	Description
Warning	Large Roundabout	Arm 1 - Large roundabout data	Large Roundabout Circulating Flow is zero for one or more arms.

Junction Network

Junctions

Junction	Name	Junction type	Use circulating lanes	Arm order	Junction Delay (s)	Junction LOS
1	untitled	Large Roundabout		1, 2, 3, 4	148.88	F

Junction Network

Driving side	Lighting	Network delay (s)	Network LOS
Left	Normal/unknown	148.88	F

Arms

Arms

[same as above]

Roundabout Geometry

[same as above]

Large Roundabout Data

Arm	Circulating flow (PCU/hr)	Has entry-to-exit separation	Entry-to-exit separation (m)
1	0	✓	122.87
2	0	✓	53.30
3	0	✓	117.42
4	0	✓	61.45

Slope / Intercept / Capacity

[same as above]

Traffic Demand

Demand Set Details

ID	Scenario name	Time Period name	Traffic profile type	Start time (HH:mm)	Finish time (HH:mm)	Time segment length (min)	Run automatically
D6	Base 2025 + Committed + Proposed	PM	ONE HOUR	15:45	17:15	15	✓

Vehicle mix varies over turn	Vehicle mix varies over entry	Vehicle mix source	PCU Factor for a HV (PCU)
✓	✓	HV Percentages	2.00

Demand overview (Traffic)

Arm	Linked arm	Profile type	Use O-D data	Average Demand (PCU/hr)	Scaling Factor (%)
1		ONE HOUR	✓	1489	100.000
2		ONE HOUR	✓	848	100.000
3		ONE HOUR	✓	603	100.000
4		ONE HOUR	✓	1146	100.000

Origin-Destination Data

Demand (PCU/hr)

		To			
		1	2	3	4
From	1	9	595	9	876
	2	455	0	196	197
	3	0	247	2	354
	4	677	200	268	1

Proportions

		To			
		1	2	3	4
From	1	0.01	0.40	0.01	0.59
	2	0.54	0.00	0.23	0.23
	3	0.00	0.41	0.00	0.59
	4	0.59	0.17	0.23	0.00

Vehicle Mix

Heavy Vehicle Percentages

		To			
		1	2	3	4
From	1	0	20	0	8
	2	22	0	8	13
	3	0	14	0	11
	4	5	9	3	0

Average PCU Per Veh

		To			
		1	2	3	4
From	1	1.000	1.200	1.000	1.080
	2	1.220	1.000	1.080	1.130
	3	1.000	1.140	1.000	1.110
	4	1.050	1.090	1.030	1.000

Detailed Demand Data

Demand for each time segment

Time Segment	Arm	Demand (PCU/hr)	Demand in PCU (PCU/hr)
15:45-16:00	1	1121	1121
	2	638	638
	3	454	454
	4	863	863
16:00-16:15	1	1339	1339
	2	762	762
	3	542	542
	4	1030	1030
16:15-16:30	1	1639	1639
	2	934	934
	3	664	664
	4	1262	1262
16:30-16:45	1	1639	1639
	2	934	934
	3	664	664
	4	1262	1262
16:45-17:00	1	1339	1339
	2	762	762
	3	542	542
	4	1030	1030
17:00-17:15	1	1121	1121
	2	638	638
	3	454	454
	4	863	863

Results

Results Summary for whole modelled period

Arm	Max RFC	Max Delay (s)	Max Queue (PCU)	Max LOS	Average Demand (PCU/hr)	Total Junction Arrivals (PCU)
1	1.20	300.61	142.7	F	1366	2049
2	1.00	89.34	22.9	F	778	1167
3	1.04	127.96	24.4	F	553	830
4	0.69	6.80	2.3	A	1052	1577

Main Results for each time segment

15:45 - 16:00

Arm	Total Demand (PCU/hr)	Junction Arrivals (PCU)	Circulating flow (PCU/hr)	Capacity (PCU/hr)	RFC	Throughput (PCU/hr)	Throughput (exit side) (PCU/hr)	Start queue (PCU)	End queue (PCU)	Delay (s)	Unsignalised level of service
1	1121	280	538	1653	0.678	1112	854	0.0	2.3	7.360	A
2	638	160	871	1199	0.533	633	779	0.0	1.3	7.341	A
3	454	113	1148	1060	0.428	451	356	0.0	0.8	6.595	A
4	863	216	533	2100	0.411	860	1066	0.0	0.7	3.047	A

16:00 - 16:15

Arm	Total Demand (PCU/hr)	Junction Arrivals (PCU)	Circulating flow (PCU/hr)	Capacity (PCU/hr)	RFC	Throughput (PCU/hr)	Throughput (exit side) (PCU/hr)	Start queue (PCU)	End queue (PCU)	Delay (s)	Unsignalised level of service
1	1339	335	643	1527	0.876	1320	1021	2.3	6.8	18.149	C
2	762	191	1036	1023	0.745	755	927	1.3	3.2	15.216	C
3	542	136	1366	806	0.673	537	425	0.8	2.2	14.723	B
4	1030	258	635	1969	0.523	1029	1268	0.7	1.1	4.021	A

16:15 - 16:30

Arm	Total Demand (PCU/hr)	Junction Arrivals (PCU)	Circulating flow (PCU/hr)	Capacity (PCU/hr)	RFC	Throughput (PCU/hr)	Throughput (exit side) (PCU/hr)	Start queue (PCU)	End queue (PCU)	Delay (s)	Unsignalised level of service
1	1639	410	769	1375	1.192	1365	1225	6.8	75.3	118.531	F
2	934	233	1117	937	0.997	883	1018	3.2	16.0	53.205	F
3	664	166	1491	659	1.007	617	508	2.2	13.9	64.300	F
4	1262	315	737	1837	0.687	1257	1372	1.1	2.3	6.485	A

16:30 - 16:45

Arm	Total Demand (PCU/hr)	Junction Arrivals (PCU)	Circulating flow (PCU/hr)	Capacity (PCU/hr)	RFC	Throughput (PCU/hr)	Throughput (exit side) (PCU/hr)	Start queue (PCU)	End queue (PCU)	Delay (s)	Unsignalised level of service
1	1639	410	773	1371	1.196	1370	1239	75.3	142.7	287.948	F
2	934	233	1121	933	1.001	906	1022	16.0	22.9	89.337	F
3	664	166	1512	635	1.045	622	515	13.9	24.4	127.957	F
4	1262	315	751	1818	0.694	1261	1383	2.3	2.3	6.796	A

16:45 - 17:00

Arm	Total Demand (PCU/hr)	Junction Arrivals (PCU)	Circulating flow (PCU/hr)	Capacity (PCU/hr)	RFC	Throughput (PCU/hr)	Throughput (exit side) (PCU/hr)	Start queue (PCU)	End queue (PCU)	Delay (s)	Unsignalised level of service
1	1339	335	671	1493	0.896	1482	1064	142.7	107.0	300.614	F
2	762	191	1134	918	0.830	827	1018	22.9	6.8	55.283	F
3	542	136	1517	629	0.862	600	444	24.4	10.0	109.786	F
4	1030	258	700	1884	0.547	1034	1417	2.3	1.3	4.480	A

17:00 - 17:15

Arm	Total Demand (PCU/hr)	Junction Arrivals (PCU)	Circulating flow (PCU/hr)	Capacity (PCU/hr)	RFC	Throughput (PCU/hr)	Throughput (exit side) (PCU/hr)	Start queue (PCU)	End queue (PCU)	Delay (s)	Unsignalised level of service
1	1121	280	555	1632	0.687	1538	872	107.0	2.8	107.728	F
2	638	160	1128	925	0.690	655	965	6.8	2.7	16.350	C
3	454	113	1418	745	0.610	487	365	10.0	1.8	17.528	C
4	863	216	562	2063	0.418	865	1343	1.3	0.8	3.166	A

Appendix C Modelling Geometries

Junction 2: A1061/ Harbrough Road / Ulceby Road / East Halton Road



Junction 3: A160 / A180

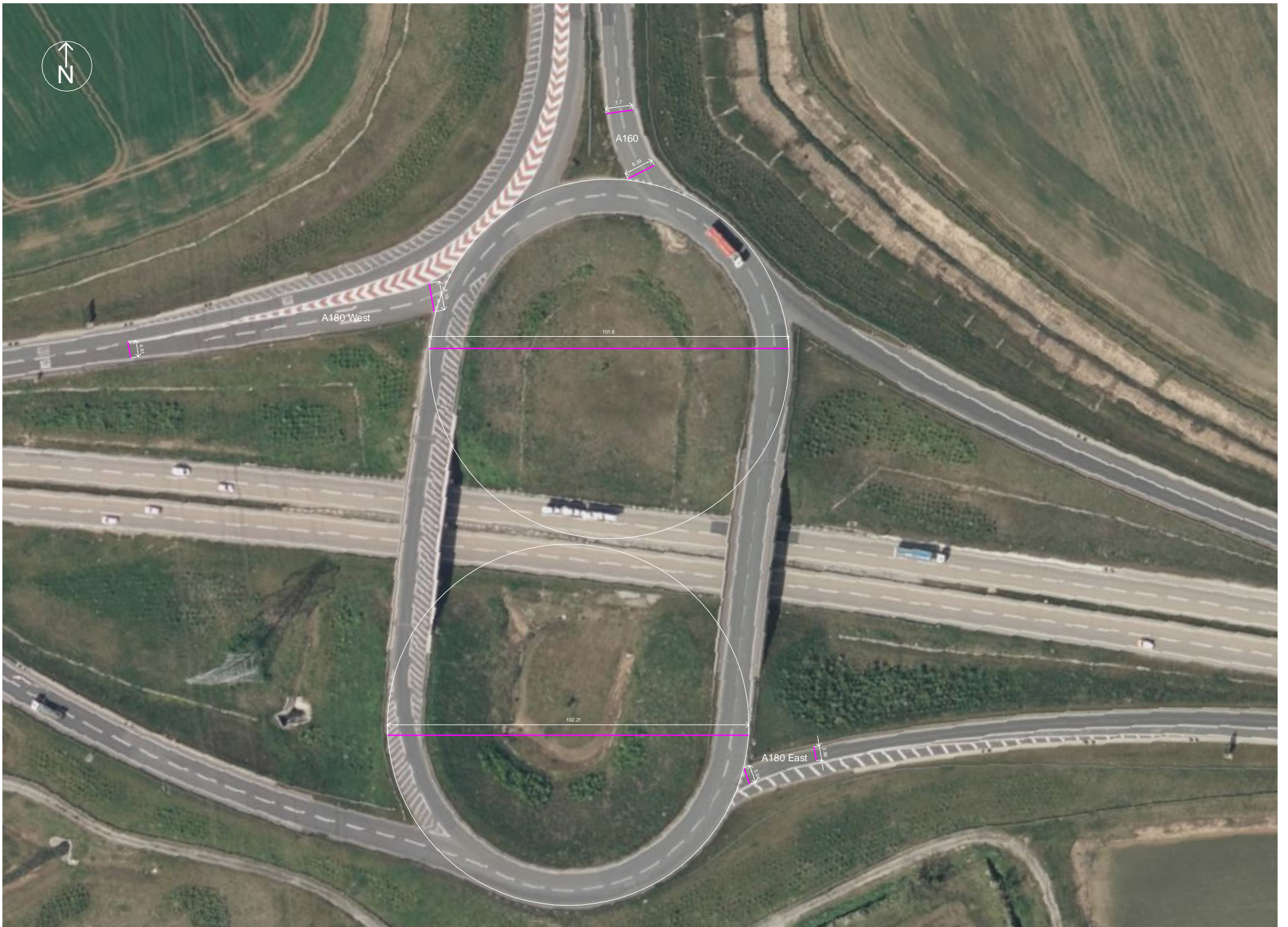

Junction 4: M180 / A15 / A18



Junction 5: A1060 / A1733 / Humber Road



Junction 6: A180 / A15

