



**WATSON  
LINDSEY**  
ARBORICULTURE

2 Church View, Main Street  
Searby  
Barnetby  
DN38 6BG

Phone: 07779071638

Email: dan@wltreereports.co.uk

**Arboricultural  
Method Statement  
to BS 5837:2012**

**Site Address:**

6-8 West St  
Scawby  
Brigg  
DN20 9AN

**Issue Date:**

24<sup>th</sup> June 2025

**Report No:**

250401

**Prepared For:**

Mr Aaron Kew  
Qube Estates Ltd  
23 West Bar Street  
Banbury  
OX16 9SA

**Prepared By:**

Daniel Kendall, TechArborA



Arboricultural  
ASSOCIATION

Technician Member

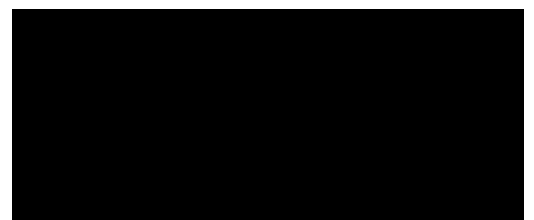

# Contents

<b>1. Introduction</b> .....	<b>3</b>
1.1. Purpose of the Report	
1.2. Scope of the Report	
<b>2. Timing of Operations</b> .....	<b>3</b>
<b>3. Legal Designations</b> .....	<b>4</b>
<b>4. Trees Works</b> .....	<b>4</b>
<b>5. The Construction Exclusion Zone (CEZ)</b> .....	<b>4</b>
<b>6. Tree Protection Fencing</b> .....	<b>5</b>
<b>7. Ground Protection</b> .....	<b>5</b>
<b>8. Temporary Buildings and Stores</b> .....	<b>6</b>
<b>9. Installation of Services within CEZ</b> .....	<b>6</b>
<b>10. New Hard Surfacing within CEZ</b> .....	<b>6</b>
<b>11. Demolition Works within CEZ</b> .....	<b>7</b>
<b>12. Construction of Buildings/Excavation within CEZ</b> .....	<b>7</b>
<b>13. Post Construction Landscaping</b> .....	<b>7</b>
<b>Appendix 1: Survey Schedule</b> .....	<b>9</b>
<b>Appendix 2: Tree Protection Fencing</b> .....	<b>11</b>
<b>Appendix 3: New Hard Surfacing</b> .....	<b>12</b>
<b>Appendix 4: Tree Protection Plan</b> .....	<b>13</b>
<b>Appendix 5: Constraints Plan</b> .....	<b>14</b>

# 1. Introduction

## 1.1. Purpose of the Method Statement

- 1.1.1. This Arboricultural Method Statement has been compiled to ensure the safe and healthy retention of retained trees on this development. Integral to achieving this goal is the implementation of the specialist construction and tree protection measures detailed within this document.
- 1.1.2. This Method Statement must be made available to all contractors and operatives on the site during the construction process so that they fully understand the importance of the measures set out for tree protection.
- 1.1.3. The information contained within this Arboricultural Method Statement conforms to BS 5837:2012 'Trees in relation to Design, Demolition and Construction - Recommendations'.

## 1.2. Scope of the Method Statement

- 1.2.1. I am instructed to produce this Arboricultural Method Statement (AMS) for the proposed development consisting of a single dwelling with associated garage and driveway. The details of the design can be found in drawing ref. 2103.01. This drawing also forms the basis for the Tree Protection Plan in Appendix 4.
- 1.2.2. This method statement is based on the tree survey carried out on 1<sup>st</sup> April 2025, and on the associated report ref. *Arboricultural Report - 250401 6-8WestStDN209AN*.
- 1.2.3. The AMS is concerned with the trees within and, where deemed necessary, those just beyond the boundary of the site, and has been compiled in order that retained trees are adequately protected throughout the course of the development. It is not intended to be used for any other purpose. The report does not consider any other trees or vegetation, except where these are specifically referred to.
- 1.2.4. The activities to which the AMS relates are; tree removal and pruning (including root pruning) for access and clearance, tree protection measures and construction methods. Risk assessments (with relevant control measures) should be produced for each of these operations prior to commencement of work. This is the duty of the contractors engaged to undertake the work.

# 2. Timing of Operations

- 2.1. To ensure that disturbance to retained trees is kept to a minimum, the site operations should proceed in the following order:

### Phase 1 - Pre-development

1. Completion of the approved tree works, (Section 4)
2. Implementation of tree protection measures including the cellular confinement system base of proposed driveway (Section 5, 6, 7, & 10)

### Phase 2 - Development

1. Adherer to site limitations resulting from tree protection measures, (Section 5, 6, & 7)
2. Where demolition is required within the RPA adherer to relevant protocols, (Section 11)
3. Where service installation is required within the RPA adherer to relevant protocols, (Section 9)

### Phase 3 - Post-development

1. Landscaping operations required outside CEZ, (Section 13)
2. Removal of tree protection measures

3. Landscaping operations required within CEZ, (Section 13)
- 2.2. Any amendments to the ordering of operations may only be made with the approval of the project arboriculturist or the Local Planning Authority (LPA) Arboricultural Officer.

### **3. Legal Designations**

- 3.1. The development site sits within a Conservation Area. Such status offers protection to all woody plants with a stem diameter of 75mm and above when measured at 1.5m above ground level (exceptions apply). This status offers protection to all trees recorded during the survey.
  - 3.1.1. Prior to works being carried out on these trees, the local authority must be given at least six weeks' notice to allow them to consider whether the proposed works are appropriate.
  - 3.1.2. Provided this method statement forms part of a successful planning application, notification to the local authority for the tree works detailed within, is not required.
- 3.2. A status investigation was made on 23<sup>rd</sup> June 2023 with North Lincolnshire District Council via their online planning portal. We are informed that there are no Tree Preservation Orders (TPO) in force on this site. We do however advise a further status investigation is carried out prior to any tree works. Conducting work without permission to a tree subject to protection is a criminal offence.

### **4. Tree Works**

- 4.1. Prior to any construction activity, the first operation on site will be the undertaking of the necessary arboricultural works, as described in the Survey Schedule at Appendix 1. These include:
  - 4.1.1. The removal of T1, T5, and G3, the locations of which can be seen on the Constraints Plan in Appendix 5.
  - 4.1.2. The pruning of T3, and G1, the details of which can be found in the Survey Schedule in Appendix 1.
  - 4.1.3. All work must be undertaken to BS 3998:2010 Tree work – Recommendations, and carried out by qualified and experienced contractors who must be adequately insured.
  - 4.1.4. Any tree defects seen by a contractor or the client that were not apparent to the project arboriculturist must be brought to our attention immediately.
- 4.2. If during the development additional access facilitation pruning is required the project arboriculturist and local authority tree officer must first be consulted. Under no circumstance shall construction personnel undertake any tree pruning operations.

### **5. The Construction Exclusion Zone (CEZ)**

- 5.1. To adequately protect retained trees a Construction Exclusion Zone (CEZ) must be formed around their crowns and Root Protection Area (RPA). The CEZ must be formed of appropriate protective fencing and/or ground protection.
- 5.2. Within the CEZ, the following restrictions shall apply unless stated otherwise in this method statement:
  - NO mechanical digging or scraping
  - NO hand digging

- NO storage of material or equipment
- NO vehicular or plant access
- NO fire lighting
- NO washing down of vehicles or machinery
- NO handling, discharging or spillage of any chemical substance including cement washings
- NO action likely to cause localised water-logging
- NO changing of ground levels (unless agreed by the LPA)
- NO earthworks

5.3. In addition to the above, further precautions are necessary adjacent to the CEZ or adjacent to any trees on neighbouring land:

- Materials that may contaminate the soil such as concrete mixing, diesel spillage and vehicle washings must not be discharged within 10m of a tree.
- This must consider the topography of the site and the slopes to avoid toxic materials running towards retained trees.
- Fires must not be lit in a position where their flames can extend to within 5 metres of the foliage, branches or trunk. This will depend on the size of the fire and the wind direction.
- Notice boards, telephone cables or other services (etc.) should not be attached to any part of a tree.

## 6. Tree Protection Fencing

- 6.1. The Tree Protection Plan (TPP) at Appendix 4 shows the position of the Tree Protection Fencing. This fencing must be erected after any tree works but before any materials or machinery are brought onto site and before any demolition, development or stripping of soil commences.
- 6.2. The protective fencing must be installed in accordance with the below ground stabilised protective fencing method as detailed in Appendix 2. All weather signage outlining the status of the CEZ should be securely fixed to the fencing. Please refer to Appendix 2 for further details of the protective fencing and signage.
- 6.3. Once erected, barriers and ground protection will be regarded as sacrosanct, and must not be removed or altered without first consulting the project arboriculturist and local authority tree officer.
- 6.4. Barriers should be fit for the purpose of excluding construction activity, and appropriate to the degree and proximity of work taking place around the retained trees. On all sites, special attention should be paid to ensuring that barriers remain rigid and complete.

## 7. Ground Protection

- 7.1. To allow general construction access across the southern RPAs of T2, G1, and G4, the cellular confinement system base of the proposed driveway must be used as ground protection. The specification and installation for this are detailed in Section 10, and in Appendix 3. The cellular confinement system base will prove adequate for construction traffic up to a maximum weight of 6 tonnes. Should access requirements differ from this the project arboriculturist must first be consulted.
- 7.2. Pedestrian development access will be necessary within the western RPA of T2, and the eastern RPA of T6. To prevent harm to tree roots, temporary ground protection must be laid. This must consist of a 75mm layer of wood chip covered with scaffold boards/heavy-duty ply-board pinned/pegged in place to prevent movement. Alternatively, where scaffolding is to be erected, a suspended walkway will provide adequate ground protection. This will be achieved by constructing a framework of scaffold poles attached to the main scaffolding. Scaffold boards will be then placed over the framework and utilised as a walkway.

- 7.3. The Tree Protection Plan (TPP) at Appendix 4 shows the position of all Ground Protection. This protection must be installed after any tree works but before any materials or machinery are brought onto site and before any demolition, development or stripping of soil commences.
- 7.4. Installation of ground protection is to take place without vehicles travelling on unprotected areas. Once installed, the ground protection will remain in place until the final landscaping phase. Removal of the ground protection will similarly take place without vehicles travelling on unprotected ground. Areas of ground protection must only be used for access and not for operations that could result in contamination by spills and run-off. Such operations may include, but may not be limited to, washing, fuelling and the storage of loose/soluble materials.
- 7.5. Where vehicles and pedestrians are required to pass over the eastern RPA of G1, the existing hard-surfacing will be used as ground protection. Once construction is complete, this can be re-surfaced if required.

## **8. Temporary Buildings and Stores**

- 8.1. The location of welfare facilities, temporary buildings, material/spoil/refuse storage, and parking (unless appropriate ground protection has been specified), must be located away from the RPA of retained trees. Areas for the mixing of chemicals, cement washing, and fuelling, must also be kept clear of the RPA of retained trees, this includes any associated runoff.

## **9. Installation of Services within CEZ**

- 9.1. As far as we are aware, no service installations are required within the CEZ. In the event service routing within the RPA is deemed necessary, these services must be installed as detailed below.

- 9.1.1. Where possible, all underground services must be routed in one excavation. During such works the location of the excavation/s must be marked on-site by an appointed engineer or another qualified person, using an appropriate method (e.g. temporary, biodegradable spray paint or pegs and lines). Hand-dug excavations must then be carried out to the required dimensions. Any roots or clumps of roots less than 25mm in diameter exposed during this operation must be cleanly severed using appropriate hand tools (e.g. hand saws or bypass secateurs). Roots or clumps of roots greater than 25mm in diameter must be retained in situ until the required excavation has been completed.

- 9.1.2. Retained roots, whilst exposed, must immediately be wrapped or covered with an appropriate material (i.e. hessian, burlap or geotextile) to prevent desiccation and to protect them from extremes of temperature. Any wrapping must be removed prior to backfilling, which must take place as soon as possible.

## **10. New Hard Surfacing within CEZ**

- 10.1. Hard-surfacing, in the form of a driveway and car parking, is proposed within the RPAs of T2, G1, and G4. A cellular confinement system must therefore be installed using a no dig technique to prevent damage to tree roots. The location of this surfacing is highlighted on the TPP at Appendix 4.
- 10.2. The design of such a system needs to be sensitive to the requirements of tree roots, substantial enough to withstand the expected levels of traffic and practicable in terms of ease of fabrication. The final surface treatment must be porous to enable the percolation of water through the surfacing to the tree roots beneath. This method is considered to be appropriate in terms of minimising damage to retained

trees. However, a structural engineer should be consulted to ensure that the mechanical needs of the chosen design are adequately met.

- 10.3. Please see Appendix 3 for specification and installation method.
- 10.4. The cellular confinement system must be laid prior to any construction work being carried out, and used as the ground protection during construction. To facilitate this a sacrificial wearing course will be installed for use during the construction phase. On completion of construction the sacrificial layer will be removed and replaced with a wearing course appropriate for domestic use.

## **11. Demolition Works within CEZ**

- 11.1. To make way for the proposed driveway, it will be necessary to demolish the existing outbuildings within the RPA of T2, G1, and G4. The location of this demolition is highlighted in the Tree Protection Plan in Appendix 4.
- 11.2. These works must be undertaken inwards onto the footprint of the existing buildings, utilising a 'top down, pull back' method. The above ground portions of these structures, their cement bases, and associated hard-surfacing may be broken and removed using self-propelled machinery. These works must utilise a 'roll-back' method, with machinery operating from existing areas of hard-surfacing, or from outside the RPA of the trees.
- 11.3. Within RPAs, the removal of any hardcore base, and sub-base, must only be carried out with manually portable tools and equipment. The extent of associated excavations must be strictly limited to what is necessary to facilitate the required degree of demolition, or limited to the level of the existing sub-soil, whichever is encountered first. Any roots exposed during the removal of the structures must be immediately covered with top-soil, or sharp sand.

## **12. Construction of Buildings/Excavation within CEZ**

- 12.1. The footprints of all buildings are located outside the RPA's of retained trees, therefore no specialist foundations are required for arboricultural purposes.

## **13. Post Construction Landscaping**

- 13.1. Following completion of the main construction phase, the protective fencing can be removed, and any temporary ground protection lifted. The landscaping phase can then commence.
- 13.2. Where new fencing is located within the RPA of retained trees, post holes must be dug by hand. Fencing systems utilising continuous trench footings must not be used in the RPA of retained trees. During excavation, roots (or clumps of roots) encountered <25 mm diameter may be pruned back, making a clean cut with a suitable sharp tool (e.g. bypass secateurs or handsaw). Roots (or clumps of roots) encountered >25mm diameter should be severed only following consultation with an arboriculturist, as such roots might be essential to the tree's health and stability.
- 13.3. Any patios, garden paths or other pedestrian accessways within the RPA, which may or may not be shown on the plans provided, must not cover more than 20% of the currently undeveloped RPA of any tree. Such surfacing must be laid using a no-dig technique. The removal of a maximum of 50mm of turf/surface vegetation is however permitted. To allow air and moisture penetration, this surfacing must consist of paving slabs or block pavers laid dry-jointed on a sharp sand or coarse aggregate no-fines foundation. Any

such surfacing situated beyond the protective fence must only be laid when the main construction phase has finished and the fencing has been removed.

- 13.4. Increases or decreases in ground level within the RPA can be extremely detrimental to trees, and must be avoided. In the event such works are deemed necessary, approval must first be sought from the project arboriculturist and the Local Planning Authority (LPA) Arboricultural Officer
- 13.5. Landscaping works must be carried out in such a way as to avoid deep digging within the RPA. Tractor mounted rotovators or other mechanised cultivation methods must not be used within the RPA of retained trees. Self-propelled machinery is not permitted in the RPA of retained trees, unless otherwise stated in this method statement.
- 13.6. Herbicides should be appropriate for the purpose and should not be used in such a way as to damage retained trees.
- 13.7. If in doubt, regarding the impact of proposed landscape operations, please contact the appointed arboriculturist.

## Appendix 1: Survey Schedule

Tree ID	Common Name	Maturity	Height (m)	Stem Diameter (mm)			RPA Radius (m)	Crown Spread (m)				Structural Condition	Retention Category	Life Expectancy	Physiological Condition	Comment	Recommendations
				1	2	3		N	E	S	W						
T1	Red Oak	Semi-mature	13	370			4.4	1	6	7.5	3	Fair / Good	B1/2	>40 yrs	Fair / Good	Single stemmed to full height. Lower crown to W, and whole crown to N, heavily suppressed by neighbouring trees. Otherwise a reasonable specimen free from notable issues.	<b>Development Recommendation:</b> Remove
T2	Common Ash	Early-mature	15	640			7.7	5.5	6	6	4.5	Fair / Good	B1/2/3	>40 yrs	Fair / Good	Possible boundary tree, ownership requires clarification. Good neloid basal form. Multiple leaders from 4m with seemingly adequate unions. Historically pollarded at 6m with large regrowth. Crown ivy clad preventing detailed assessment. Crown height over site of 5m.	n/a
T3	Lawson Cypress	Young	7	160			1.9	0	1.5	3	1.5	Poor / Fair	C2	10 to 20 yrs	Poor / Fair	Heavily suppress by neighbouring trees, especially to N.	<b>Development Recommendation:</b> Crown lift to south, over proposed driveway, from 0.5m to 3.5m.
T4	Common Holly	Semi-mature	9	240	180	100	3.8	6	2.5	3	3.5	Fair	C2	20 to 40 yrs	Fair	Possible boundary tree, ownership requires clarification. Trifurcated from 1m, and historically pollarded at 4m resulting in a heavily congested crown. Crown ivy clad preventing detailed assessment. Provides reasonable screening.	n/a
T5	Common Ash	Early-mature	15	650			7.8	6	5	6.5	7	Fair / Good	B1/2/3	>40 yrs	Fair / Good	Possible boundary tree, ownership requires clarification. Good neloid basal form. Multiple leaders from 3m with seemingly adequate unions. Historically pollarded at 4.5m with large regrowth. Crown ivy clad preventing detailed assessment.	<b>Development Recommendation:</b> Remove
T6	Common Ash	Semi-mature	14.5	400	350	320	7.4	7.5	7	8.5	6.5	Fair	C1/2	>40 yrs	Fair / Good	Possible boundary tree, ownership requires clarification. Heavily ivy clad preventing detailed assessment. Trifurcated from 1m, and historically pollarded at 5m, with medium regrowth resulting in a heavily congested spreading crown, with multiple slender leaders.	n/a

Tree ID	Common Name	Maturity	Height (m)	Stem Diameter (mm)			RPA Radius (m)	Crown Spread (m)				Structural Condition	Retention Category	Life Expectancy	Physiological Condition	Comment	Recommendations
				1	2	3		N	E	S	W						
T7	Common Ash	Semi-mature	14.5	470			5.6	6.5	5	6.5	5	Good	B1/2	>40 yrs	Fair / Good	Possible boundary tree, ownership requires clarification. Heavily ivy clad preventing detailed assessment. Single stemmed to full height with a well-balanced crown.	n/a
G1	A Group	Semi-mature	12	200 <sup>a</sup>	180 <sup>a</sup>	160 <sup>a</sup>	3.8	4	5.5	4	4	Fair / Good	C2	>40 yrs	Fair / Good	Situated beyond boundary fence. Location prevented detailed assessment. Containing two self-set ash trees, growing in close competition immediately adjacent to existing garage wall.	<b>Development Recommendation:</b> Crown lift to south, over existing, and proposed driveway, from 2m to 3.5m.
G2	A Group	Semi-mature	12	200 <sup>a</sup>			2.4	1.5	1.5	1	1.5	Fair / Good	C2	20 to 40 yrs	Fair / Good	Containing two different cypress cultivars, split E to W. Collectively provide good screening.	n/a
G3	A Group	Early-mature	11	300 <sup>a</sup>	220 <sup>a</sup>		4.5	2.5	4.5	3	4.5	Fair	C2	20 to 40 yrs	Fair / Good	Containing two different cypress cultivars growing in close competition. Unmanaged with poor form.	<b>Development Recommendation:</b> Remove
G4	A Group	Semi-mature	13	300 <sup>#a</sup>	250 <sup>#a</sup>		4.7	5.5	3	4.5	2.5	Fair / Good	C2	>40 yrs	Fair / Good	Two sycamores situated in adjacent grounds. Location prevented detailed assessment. W specimen multi stemmed with a congested crown. E suppressed by tree to W with slender form. Crown height over site of 4.5m.	n/a

<sup>a</sup> denotes average diameter of most significant trees (groups of trees)

<sup>#</sup> denotes estimated measurement

## Appendix 2: Tree Protection Fencing

Figure 1. Specification for Below Ground Stabilised Protective Fencing

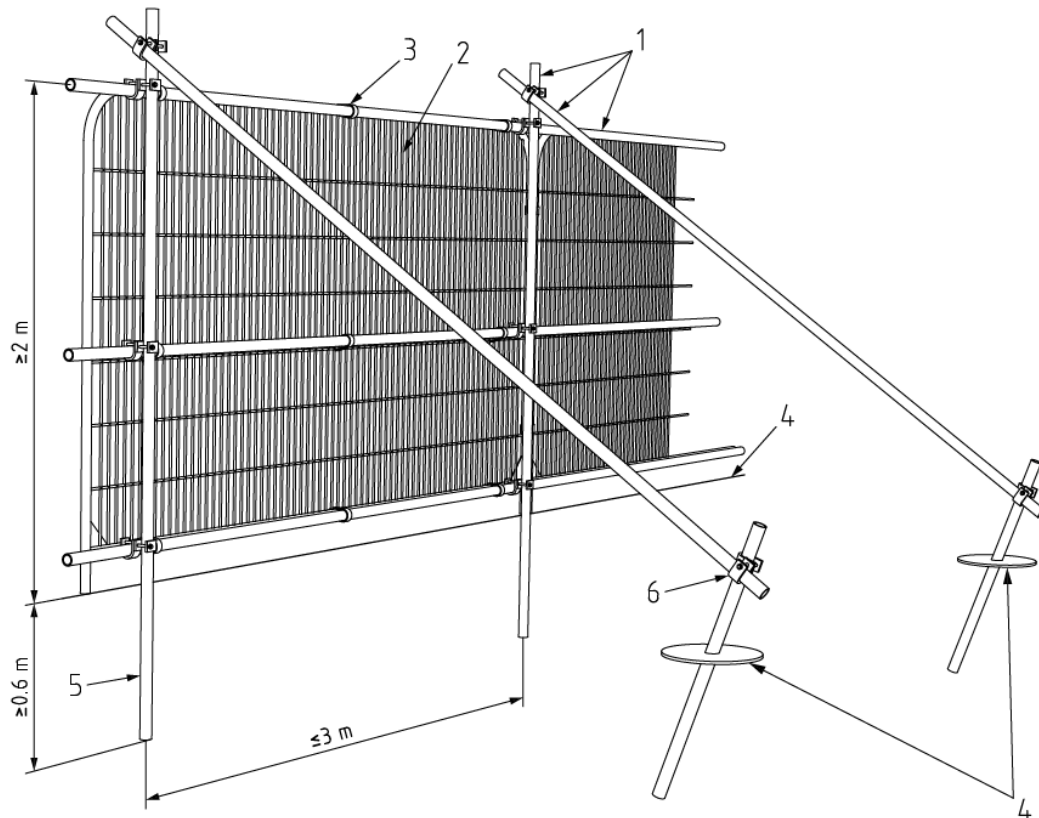

### Key

- 1 Standard scaffold poles
- 2 Heavy gauge 2 m tall galvanized tube and welded mesh infill panels
- 3 Panels secured to uprights and cross-members with wire ties
- 4 Ground level
- 5 Uprights driven into the ground until secure (minimum depth 0.6 m)
- 6 Standard scaffold clamps

Figure 2. Example Signage for Protective Fencing

# TREE PROTECTION AREA

TREES ENCLOSED BY THIS FENCE ARE PROTECTED BY PLANNING CONDITIONS AND ARE SUBJECTS OF A  
TREE PRESERVATION ORDER  
(TOWN & COUNTRY PLANNING ACT 1990)

CONTRAVENTION OF TREE PRESERVATION ORDERS MAY LEAD TO CRIMINAL PROSECUTION

THE FOLLOWING **MUST** BE OBSERVED BY ALL PERSONS:-

- THE PROTECTIVE FENCING MUST NOT BE REMOVED
- NO PERSON SHALL ENTER THE PROTECTED AREA
- NO MACHINE OR PLANT SHALL ENTER THE PROTECTED AREA
- NO MATERIALS SHALL BE STORED IN THE PROTECTED AREA
- NO SPOIL SHALL BE DEPOSITED IN THE PROTECTED AREA
- NO EXCAVATION SHALL OCCUR IN THE PROTECTED AREA

ANY INCURSION INTO THE PROTECTED AREA MUST BE  
WITH THE WRITTEN PERMISSION OF THE LOCAL PLANNING AUTHORITY

# KEEP OUT!

## Appendix 3: New Hard Surfacing

This Appendix outlines the options available for constructing No-dig hard surfaces within the RPA of trees. We are not qualified to recommend any particular construction method in terms of durability or structural integrity and any proposed construction should be approved by a qualified structural engineer prior to implementation.

### The No-Dig Method:

This involves construction of a surface with no excavation, soil stripping or site grading (see Figure 3 & 4). All construction must take place above ground level including any edge support. Such support must utilise sleepers/kerbs/gabions (pinned in place where required), kerbs mounted on a cement filled 3D cellular confinement system, or other non-invasive structures. Where the subgrade has a California Bearing Ration (CBR) of <3, an additional sub-base may be required. Preparation and installation for such hard-surfacing is as follows:

1. Kill off ground vegetation using a systemic herbicide (i.e. glyphosate) applied to the foliage and remove resulting dead organic material.
2. Removed any turf/surface vegetation (up to a maximum depth of 50mm) as well as any significant localised protrusions. Fill minor hollows with sharp sand.
3. Lay a recognised geo-fabric over the area and extend to 300mm beyond boundaries whilst overlapping any joints by 300mm.
4. Major hollows or levelling can now be achieved using aggregate specified at point no.7. Note – no plant machinery may enter the RPA until the 3D cellular confinement system is installed and filled.
5. Using a no dig method, construct suitable edge support for the new surface.
6. Install an appropriate 3D cellular confinement system. In such instances confinement systems of 100mm depth would ordinarily be appropriate, this must however be verified by a structural engineer.
7. Infill with a clean (no fines) angular stone type 4/20 or 20/40 using a ‘roll-out’ technique with plant machinery operating from outside the RPA or from already infilled areas. Cells must be filled to their maximum volume and then over filled by 25mm. No additional compaction is required beyond a limited number of passes with lightweight tracked plant machinery.
8. To form a sacrificial layer for construction traffic cover with a recognised geo-fabric extending to 300mm beyond boundaries whilst overlapping joints by 300mm. Cover with 50-75mm of type 1 roadstone. On completion of construction phase remove layer of type 1 roadstone and geo-fabric.
9. Install new layer of geo-fabric extending to 300mm beyond boundaries whilst overlapping joints by 300mm.
10. Install final porous surface as per client specification.

**Figure 3:**  
Example, no-dig surfacing –  
Level ground

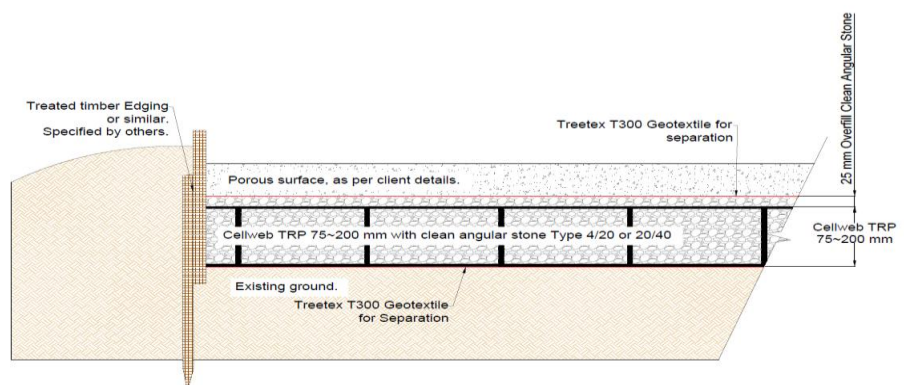

**Figure 4:**  
Example, no-dig surfacing –  
Uneven ground

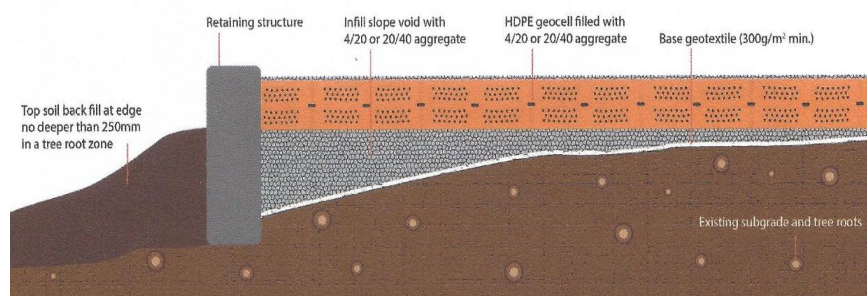

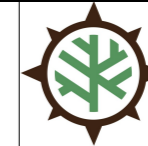

**WATSON  
LINDSEY**  
ARBORICULTURE

Phone: 07779071638  
Email: dan@wtreereports.co.uk  
Web: wtreereports.co.uk

### Appendix 4: Tree Protection Plan

SCALE : 1 : 200 @ A3 DATE : 24/06/2025



MAP FILENAME :  
TPP - 250401 6-8WestStDN209AN

Map data shown may contain Ordnance Survey © products supplied by  
Pear Technology Services Ltd; Email: info@peartechnology.co.uk  
© Crown Copyright and database rights from date shown above  
Ordnance Survey © licence number 100023148

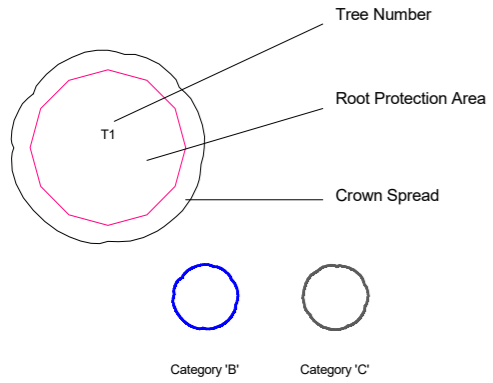

- Ground Protection - Pedestrian
- No-dig Hard-surfacing
- Demolition
- Tree Protection Fencing

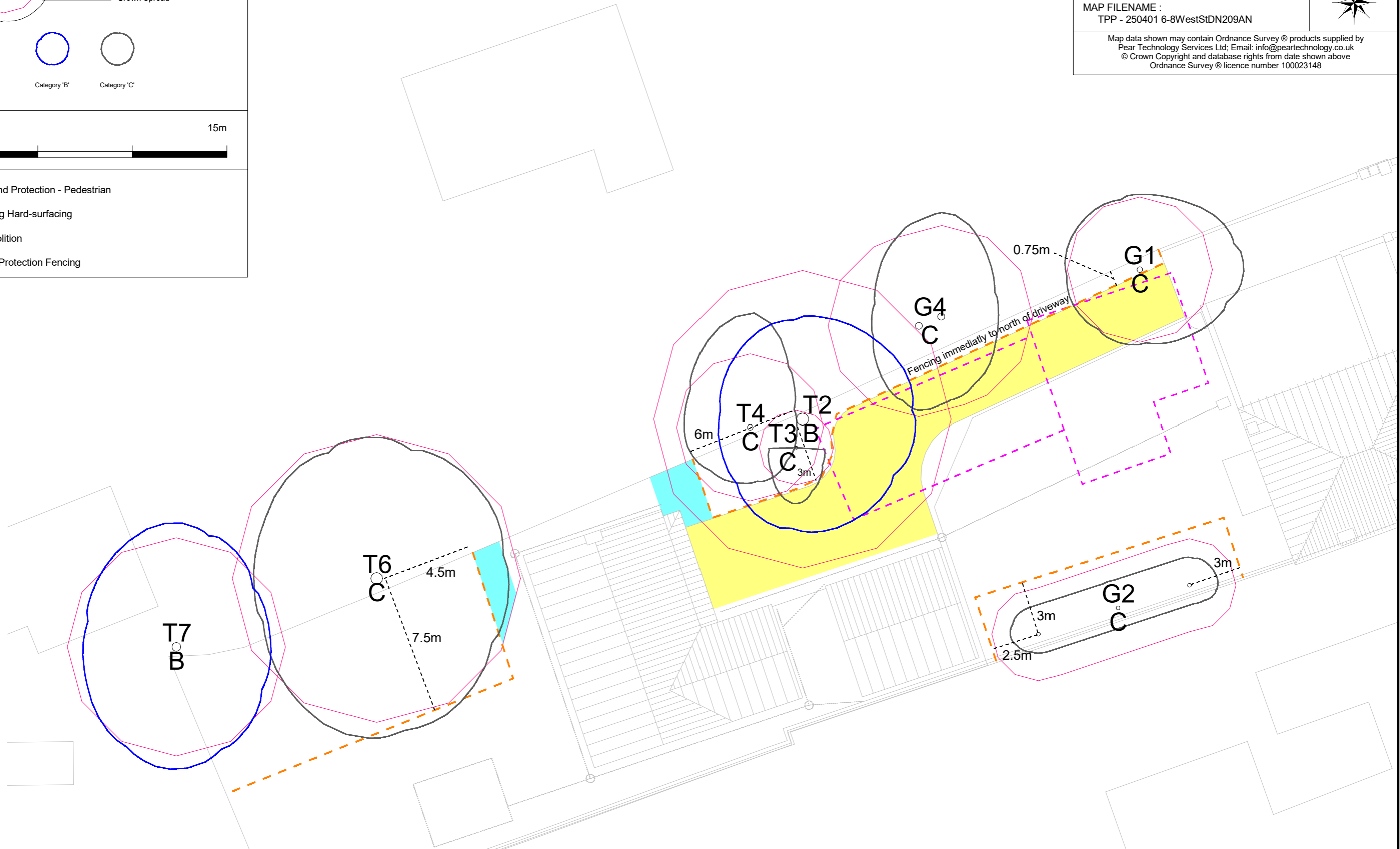

## Appendix 5: Constraints Plan

SCALE : 1 : 200 @ A3  
 DATE : 01/05/2025



MAP FILENAME : CP - 250401 6-8WestStDN209AN

Map data shown may contain Ordnance Survey © products supplied by  
 Pear Technology Services Ltd; Email: info@peartechnology.co.uk  
 © Crown Copyright and database rights from date shown above  
 Ordnance Survey © licence number 100023148

