

SHW01 ALTHON SFA16 B PLAN VIEW  
SCALE 1:20

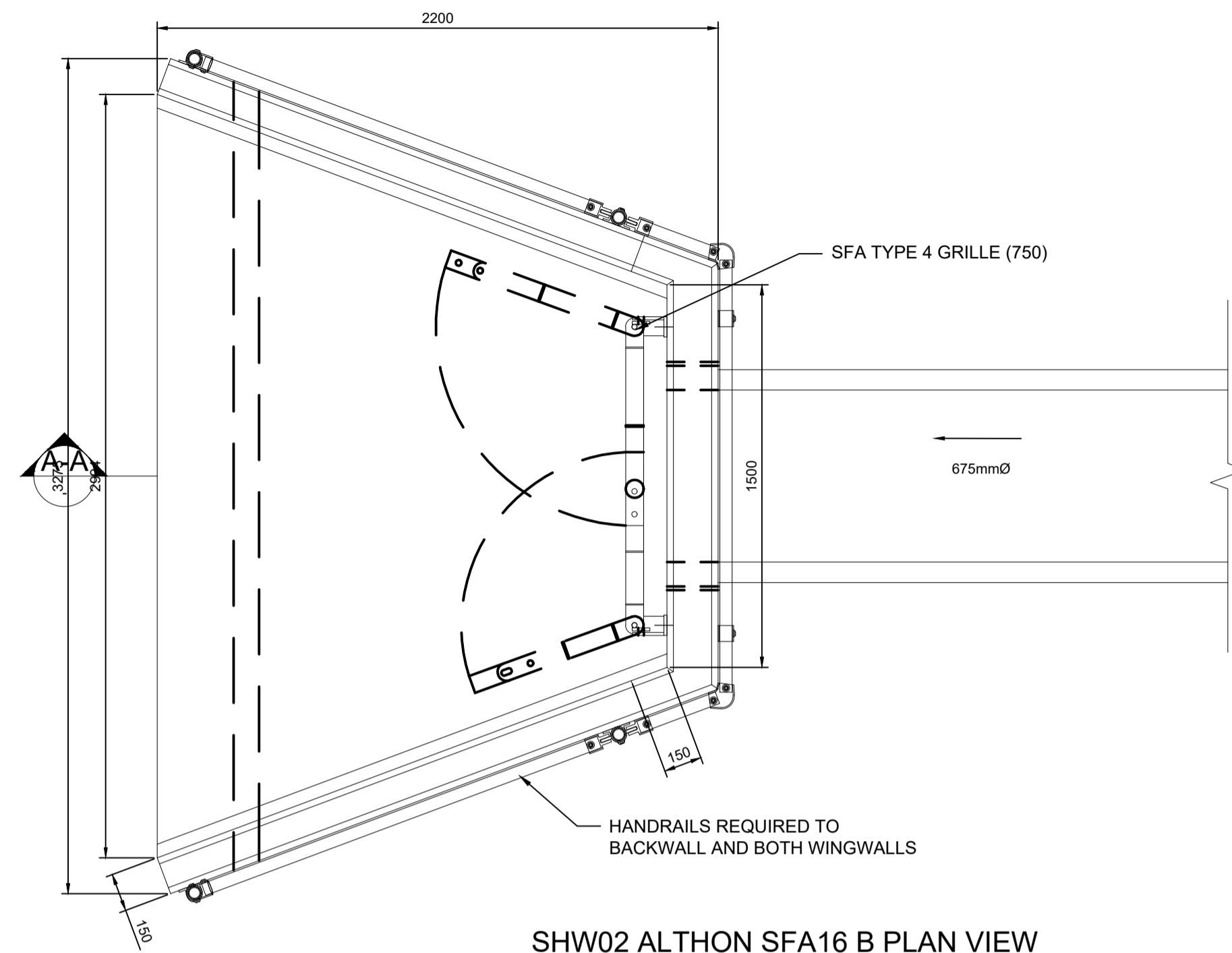

SHW02 ALTHON SFA16 B PLAN VIEW  
SCALE 1:20

**NOTES:**

- All dimensions in mm
  - All measurements  $\pm 1$ mm
- SPECIFICATION INFORMATION:**
- Opening in back wall cast to suit outside diameter of the pipework
  - Invert level of pipe can be set to your specification

**HEADWALL INSTALLATION:**

- A. Units should be bedded on minimum 150mm thick well compacted Class GN or GN\* well graded granular material with a 50mm topping of fine material (Class 6L\*) to ensure units are level and stable.
- \*Manual of contract documents for Highway Works: Volume (MCHW1) specification for Highway Works, Series 600 (Nov 09).

**HANDLING:**

- A. Weight of concrete is based on 2.4 tonne/m<sup>3</sup>+5% is recommended for sizing lifting equipment.
- B. All lifting points shall be used as specified below
- C. Unit to be lifted as per lifting diagram

**CONCRETE:**

- A. Mix ref: Self-compacting DC4/DS4 Mix
- B. Lifting strength based on 2 cubes = 20N/mm<sup>2</sup>
- C. Characteristic 28 day cube strength = 50N/mm<sup>2</sup>
- D. Concrete provides Design Chemical Class 4 (DC4) to special Digest 1, Table F2.

**REINFORCEMENT:**

- A. Reinforcement to BS EN 13369
- B. Scheduling, dimensioning, bending & cutting to BS8666
- C. Cage to be machine tied with steel wire

**MANUFACTURE:**

- A. Manufacture to BS EN 15258:2008 precast concrete products - Retaining wall elements, Factory Production Control certificate number: 0086-CPR-650448 & BS EN 13369
- B. Tolerances to BS EN 13369 clause 4.3.1.1
- C. Finishing:
- | Top  | Side | Base | Face of back wall |
|------|------|------|-------------------|
| ±0.5 | ±0.5 | ±0.5 | ±0.5              |
- D. Marking: Units shall be indelibly marked to show:
- Mould reference code
  - De-mould date
  - Job reference number & unique product number
  - Unit weight (kg)

**DESIGN:**

- A. Concrete design to EC2
- B. Althon have designed the concrete units only, the site conditions should be assessed for suitability by the scheme designer
- C. Units are designed to withstand a vertical live load surcharge of 10kN/m<sup>2</sup>
- D. Weight of soil = 18kN/m<sup>3</sup>
- E. Angle of internal friction = 30 Deg.
- F. Design Life: >120 years

Mix Class	Concrete	Reinforcement	Design	Code
DC4/DS4	20	20	20	20

**FABRICATION SPECIFICATION:**

- A. Manufacture IAW EN 1090-2 EXC CLASS 1
- B. Material grade is to be: BS EN 10025 S275
- C. Welding carried out IAW EN 1090-2 PARA 7.5.4 - 7.5.18
- D. All fillet and butt welds to have a minimum throat thickness of 6mm & joints to be fully welded where possible.
- E. Ensure vertical flats are fully welded both sides where possible.
- F. All sharp edges and burrs are to be removed.
- G. Remove all weld splatter.
- H. Holes by punching are permitted with reaming.
- I. Galvanising is carried out after fabrication to BS EN ISO 1461

**HANDRAIL SPECIFICATION:**

- A. Kee Klamp® Galvanised Size 8 Fittings
- B. Size 8 48.3mm OD 3.2mm Wall Thickness Galvanised Medium Duty Tube to BS EN 10255
- C. 360N/m Design Load at stated in BS 8118, BS 6180, BS 6399 & BS 7818, Civil Engineering Specification for the Water Industry (CESWI) 7th Edition Clause 2.50 Handrails & Balusters & The Engineering Equipment and Materials Users' Association (EEMUA) Publication 105 7th Edition Factory Stairways, Ladders and Handrails
- D. Other design loads available on request
- E. GRP/FRP Handrails also available

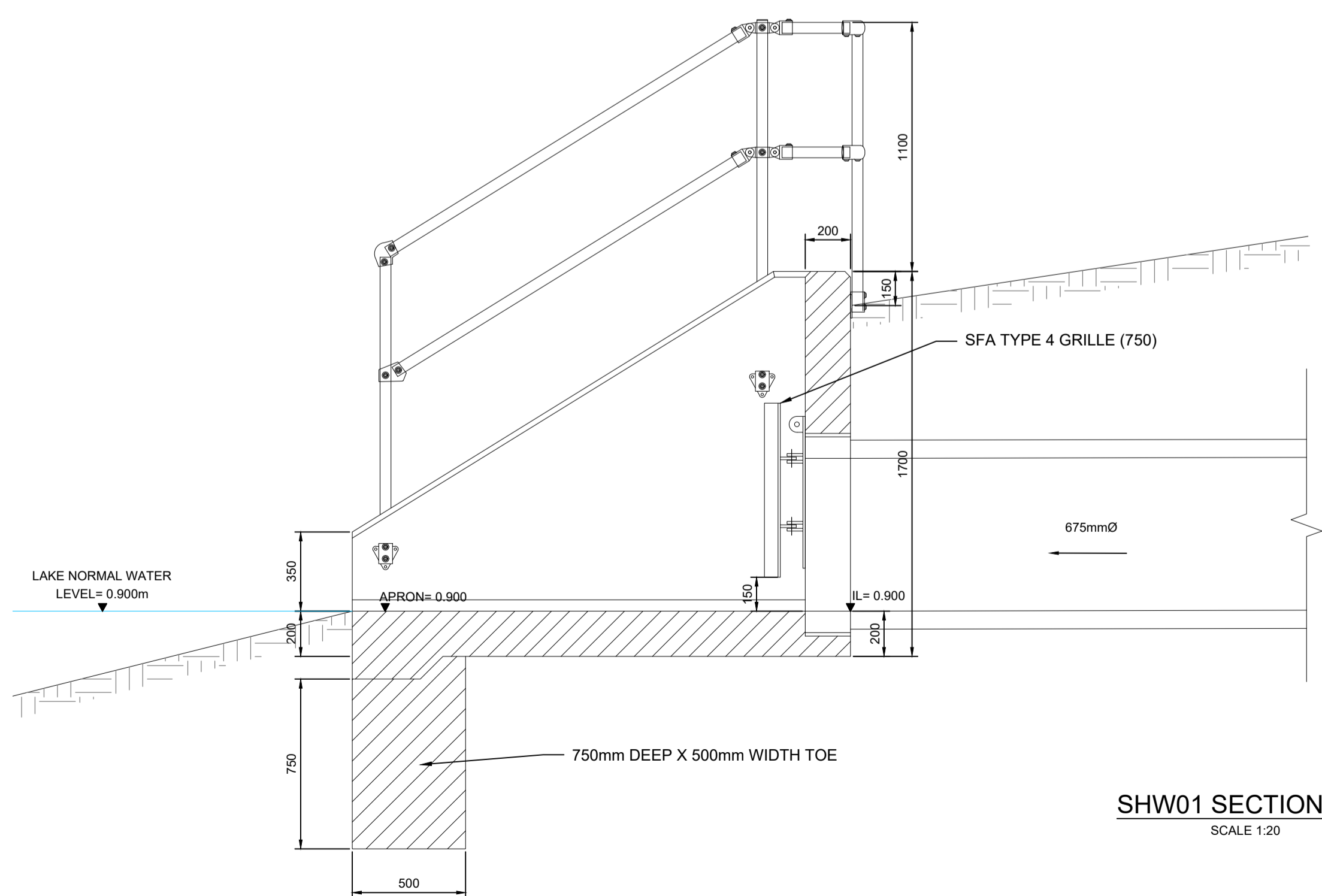

SHW01 SECTION A-A  
SCALE 1:20

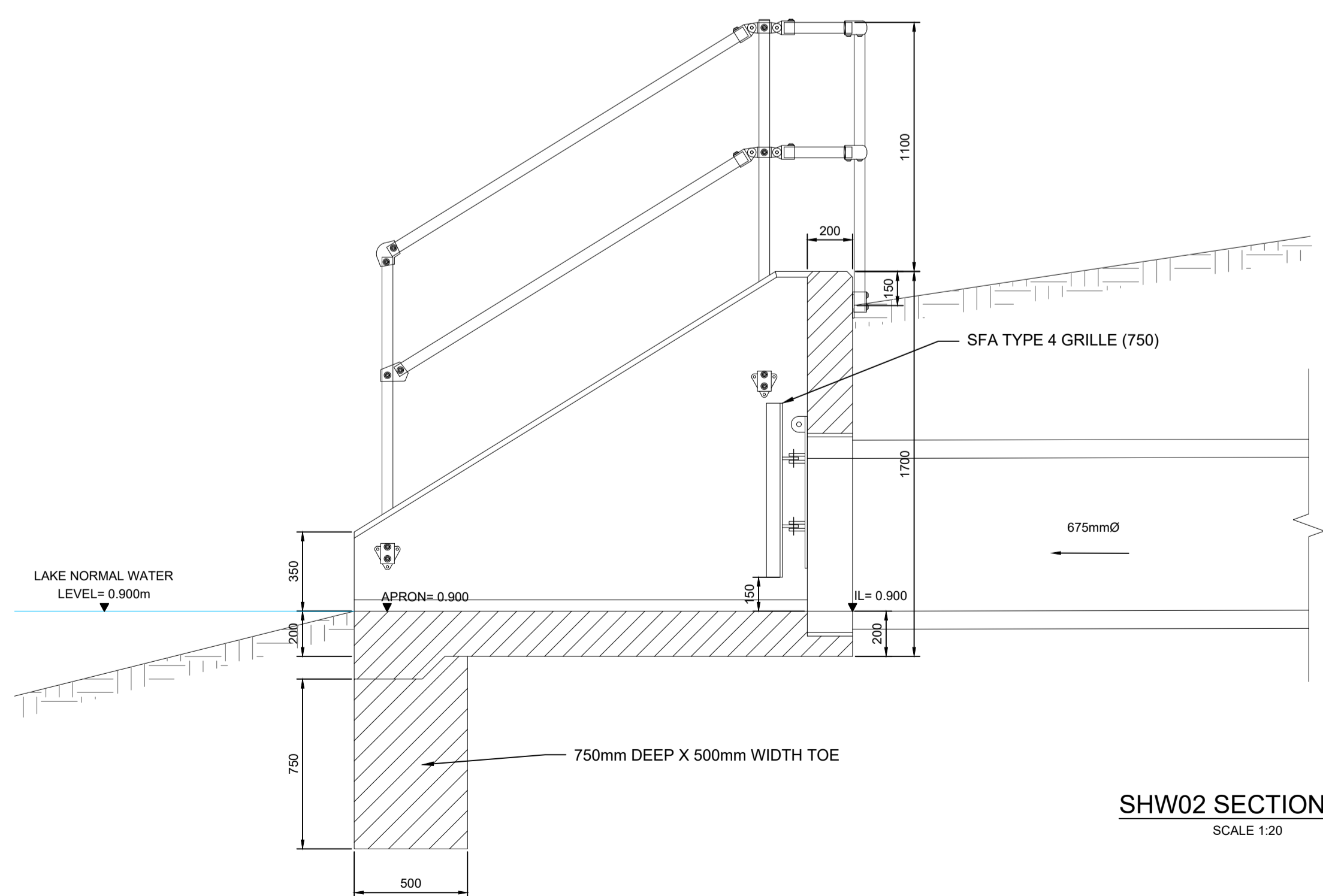

SHW02 SECTION A-A  
SCALE 1:20

**NOTES:**

- THESE NOTES ARE INTENDED TO AUGMENT DRAWINGS AND SPECIFICATIONS. WHERE CONFLICT OF REQUIREMENTS EXIST THE ORDER OF PRECEDENCE SHALL BE AS SHOWN IN THE SPECIFICATION, OTHERWISE THE STRICTEST PROVISION SHALL GOVERN.
- THIS DRAWING IS TO BE READ IN CONJUNCTION WITH ALL OTHER RELEVANT ENGINEERS AND ARCHITECTS DRAWINGS.
- DRAWINGS NOT TO BE SCALED. ALL DIMENSIONS TO BE CHECKED ON SITE BY THE CONTRACTOR. ANY DISCREPANCIES TO BE NOTIFIED TO THE ENGINEER AND FURTHER INSTRUCTIONS OBTAINED BEFORE WORK IS COMMENCED.
- THE STRUCTURE IS DESIGNED TO BE SELF-SUPPORTING AND STABLE AFTER THE BUILDING IS FULLY COMPLETED. IT IS THE CONTRACTORS SOLE RESPONSIBILITY TO DETERMINE THE ERECTION PROCEDURE AND SEQUENCE AND ENSURE THAT THE BUILDING AND ITS COMPONENTS ARE SAFE DURING ERECTION. THIS INCLUDES THE ADDITION OF WHATEVER TEMPORARY BRACING, GUYS OR TIE-DOWNS WHICH MAY BE NECESSARY. SUCH MATERIAL REMAINING THE PROPERTY OF THE CONTRACTOR ON COMPLETION, AND FOR ENSURING THAT THE WORKS AND ANY ADJACENT PROPERTIES ARE SAFE IN THE TEMPORARY CONDITION.

Rev	Description	Date	By	Chk	App
P3	AMENDED TO NEW S104 DESIGN, SHOWING SHW01 AND SHW02	13.08.25	JP	SPG	SPG
P2	HEADWALL SPECIFICATION NOTES ADDED	25.07.24	ERD	JP	BH
P1	FIRST ISSUE	09.02.24	ERD	JP	JAG

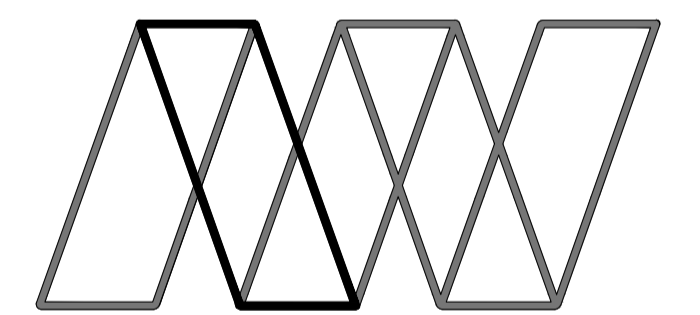

**Alan Wood & Partners**

<b>Hull Office</b> 341 Beverley Road Hull HU5 1LD	<b>Consulting Civil &amp; Structural Engineers</b> <b>Project Managers</b> <b>Building Surveyors</b>
T. 01482 442138 www.alanwood.co.uk	Leeds T. 01135 311098 Lincoln T. 01522 300210 Scarborough T. 01723 865484 Sheffield T. 01142 440077 York T. 01904 611594

Project:	Proposed Residential Development at Lincolnshire Lakes, Burringham Road				
Client:	Keepmoat Homes				
Drawing:	Section 104 - Surface Water Headwall Details Sheet 1				
Role:	CIVIL ENGINEER				
Drawing Status:	FOR APPROVAL	Suitability Code:	S4		
Job no.:	45822	Scale@ A1:	As Noted	Rev.:	P3
Project	Originator	Volume	Level	Type	Role
KPLL - AWP - ZZ - XX - DR - C - 3041					